

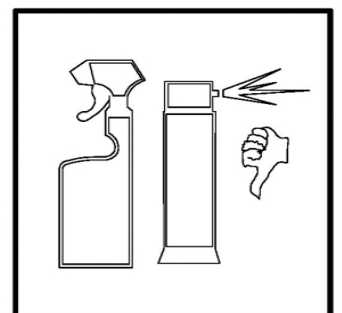

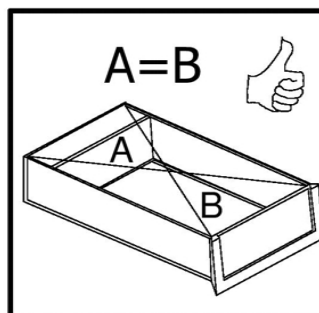

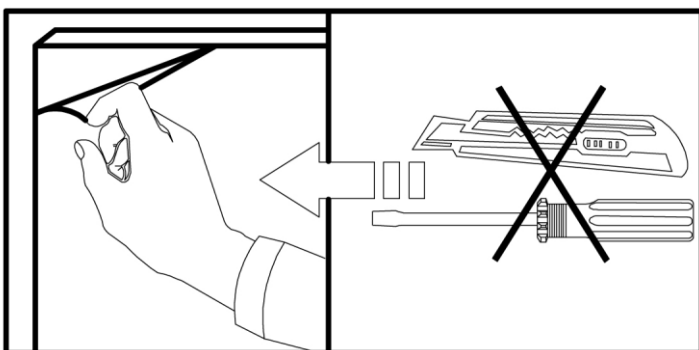

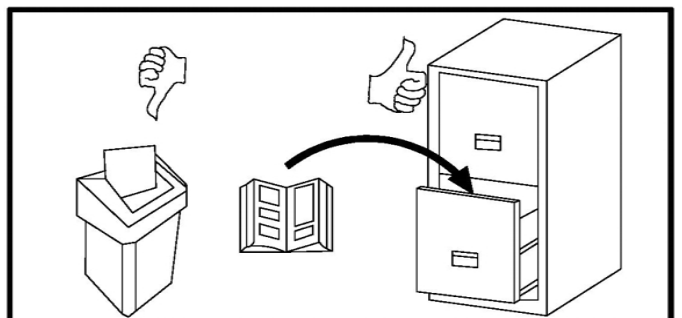

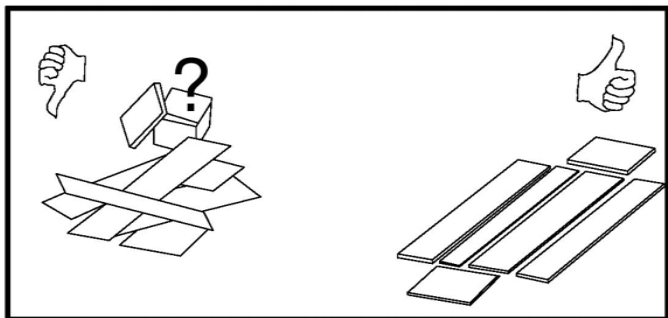
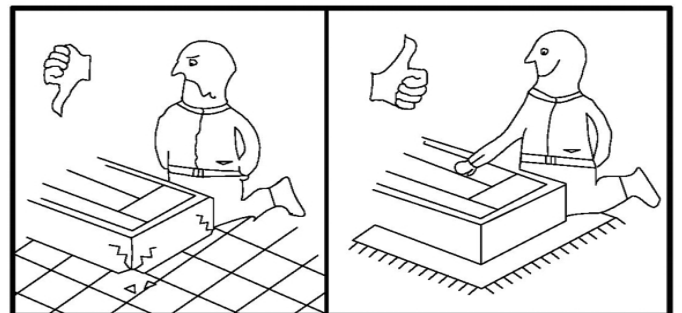
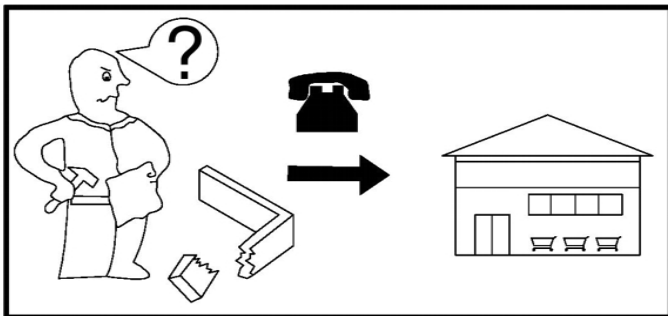
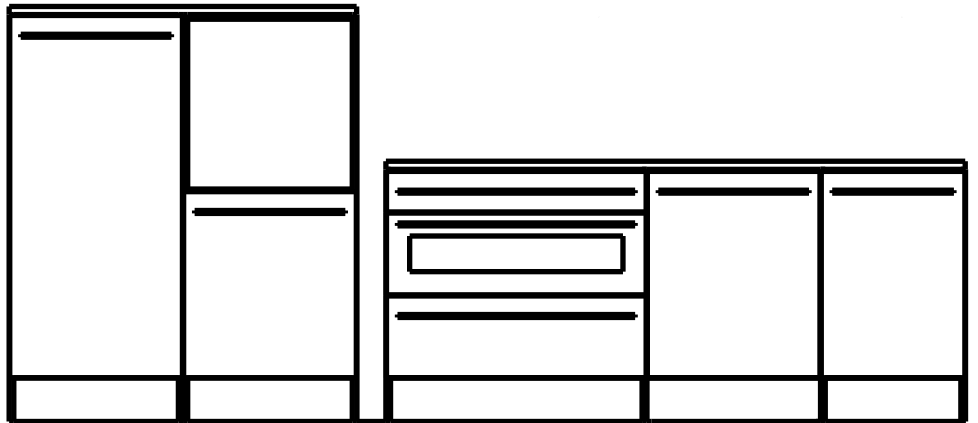
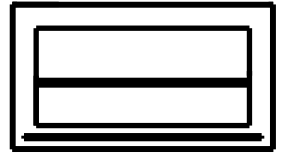
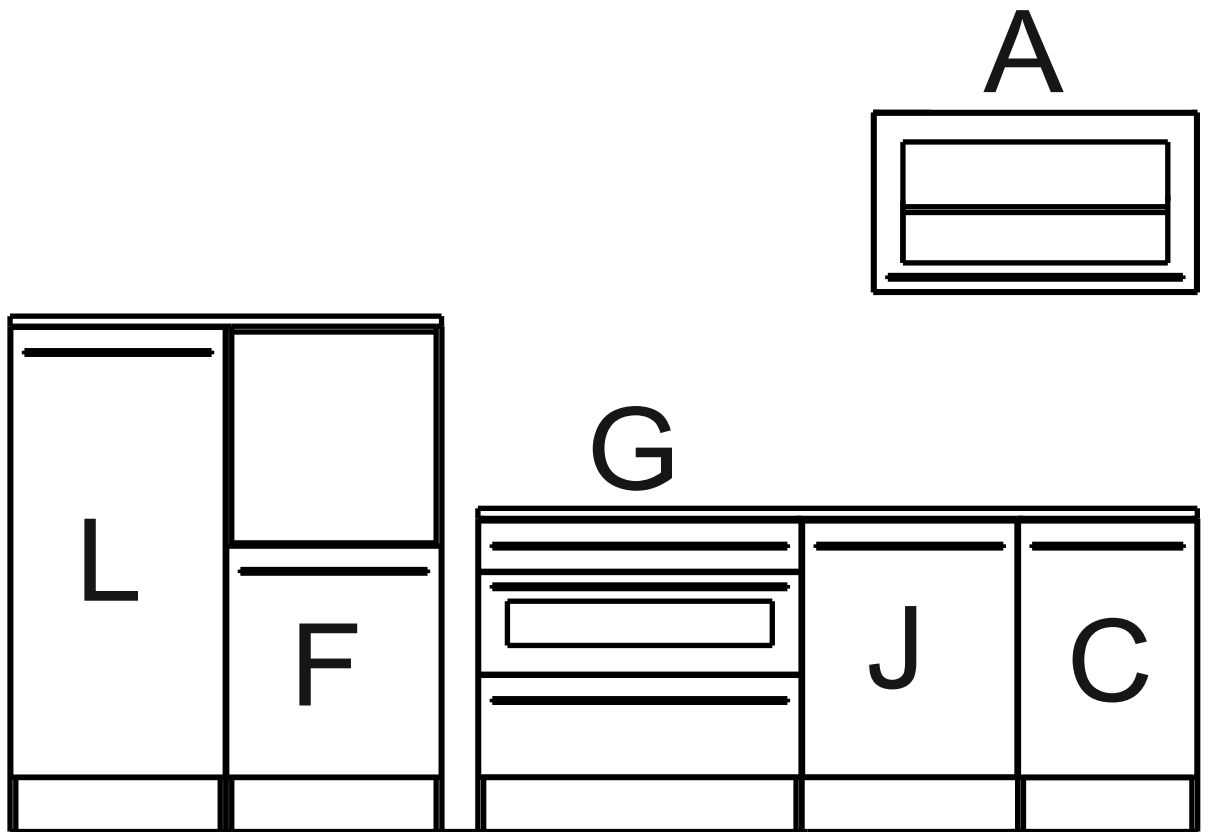
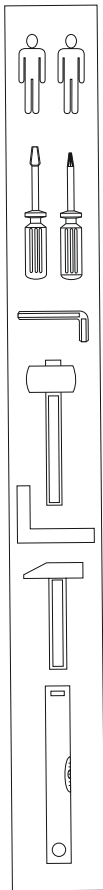

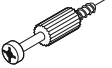

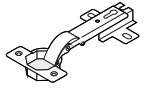

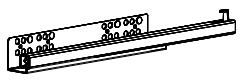
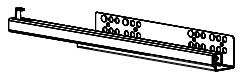
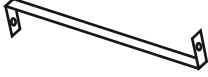

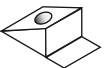





WELCOME JAZZ 2







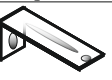

1	 8mm x 35mm	<u>x 44</u>
2	 8mm x 35mm	<u>x 42</u>
39	 3x20	<u>x 102</u>
4A	 4mm x 16mm	<u>x 54</u>
5		<u>x 9</u>
6	 5mm x 11mm	<u>x 30</u>
92A		<u>x 3</u>
92B		<u>x 3</u>
37		<u>x 6</u>

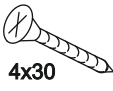
31		<u>x 10</u>
26		<u>x 1</u>
38		<u>x 18</u>
9		<u>x 42</u>
9A		<u>x 42</u>
11	 3.5x13	<u>x 16</u>
17		<u>x 1</u>
18		<u>x 1</u>
40		<u>x 16</u>

22	 7mm x 50mm	<u>x 42</u>
22A		<u>x 42</u>
13		<u>x 8</u>
10A		<u>x 16</u>
85A		<u>x 2</u>
85B		<u>x 2</u>
41		<u>x 2</u>
31B		<u>x 4</u>
86		<u>x 4</u>

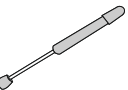
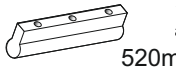
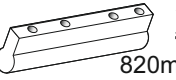
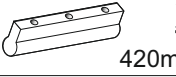
21	 4x30	<u>x 14</u>
91		<u>x 2</u>
4	 3.5x30	<u>x 28</u>
76A		<u>x 2</u>
76B		<u>x 2</u>
76C		<u>x 2</u>
3A	 520mm	<u>x 3</u>
3B	 820mm	<u>x 4</u>
3C	 420mm	<u>x 1</u>

Allgemeine Hinweise

Die Montage einer Einbauküche sollte von entsprechend geschulten Fachkräften durchgeführt werden. Vor der Montage müssen die Montagehinweise gelesen werden.

Spezielle, weiterführende Montageanleitungen und Hinweise liegen den Geräten, Spülen, Beleuchtungen und Sonderausstattungen bei und müssen zusätzlich beachtet werden.

Für die Befestigung von Wandhängeelemente gilt:



Wir legen kein Befestigungsmaterial bei. Bitte prüfen Sie die gegebene Wandbeschaffenheit und wenden Sie sich an den örtlichen Fachhandel zum Erwerb der passenden Dübel / Haken / Aufhängeschienen / Schrauben

Für die Aufhängung können entweder Haken oder Aufhängeschienen verwendet werden.

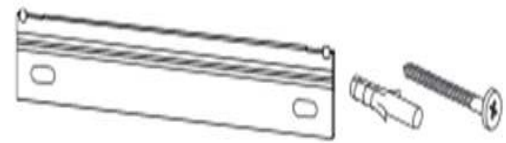

Die Hängeschränke können bei korrekter Montage mit ca. 40 kg belastet werden. Achten Sie auf eine gleichmäßige Lastverteilung

Bei Nichtbeachtung der Montagehinweise können wir entstandene Schäden keine Haftung übernehmen

Achten Sie darauf bei Einzelschränken, oder der gesamten Küchenzeile eine Kippsicherung anzubringen

Sanitär- und Elektroinstallationen dürfen nur von einer entsprechenden Fachkraft vorgenommen werden

Vor Bohrarbeiten muss geprüft werden, dass an der Stelle des Bohrens keine Leitungen für Gas, Wasser, Strom, Heizung oder Abflüsse verlegt wurden

Es dürfen keine verändernden Manipulationen am Zubehör oder an Elektrogeräten vorgenommen werden. Dies gilt insbesondere für Befestigungsbohrungen.

Überprüfen Sie vor der Montage ob alle Anschlüsse vorhanden sind und fachgerecht ausgeführt wurden

Die Küche beinhaltet verschluckbare Kleinteile. Kinder unter 3 Jahre nicht ohne Beaufsichtigung lassen



Empfohlenes Vorgehen bei der Küchenmontage:

Planen Sie den genauen Montageort unter Berücksichtigung Ihrer Sanitär- und Elektroanschlüsse

Prüfen Sie ob Ihr Kühl- Gefriergerät Lüftungsauslässe im Sockelbereich bzw. im Bereich der Arbeitsplatte benötigt

Erwerben Sie ggf. passende Lüftungsgitter im Fachhandel und schneiden Sie den Sockel bzw. die Arbeitsplatten gemäß den Anweisungen des Geräteherstellers aus.

Legen Sie fest, ob Sie die Türen mit Rechts- oder Linksanschlag montieren wollen

Montieren Sie zunächst die Unterschränke und richten Sie diese mit einer Wasserwaage aus.



Erst wenn alles exakt steht, verbinden Sie die einzelnen Schränke mit Schrauben. Damit dabei nichts verrutscht, empfehlen wir Ihnen dringend den Einsatz von zwei Schraubzwingen. Die Schrankoberflächen schützen Sie mit Zulagehölzern vor Eindrücken.

Ermitteln Sie durch exaktes Messen die Positionen der Bohrungen für die Hängebeschläge

Legen Sie die Arbeitsplatte auf die Korpusse, richten Sie sie aus, und fixieren Sie sie mit Zwingen. markieren Sie die Lage und -breite des Herdunterschrankes.

Auf der Unterseite der Arbeitsplatte reißen Sie im markierten Bereich den Herdplattenausschnitt auf. Mitteln Sie sie aus, so dass die Spüle mittig im Unterschrank sitzt und vorne und hinten die Plattenrestbreite gleich wird.



Empfohlenes Vorgehen bei der Küchenmontage:

Bohren Sie in den vier Ecken jeweils ein 10-mm-Loch zum leichteren Einsetzen der Stichsäge, und schneiden Sie den Herdausschnitt entlang Ihrer Risse aus. Arbeiten Sie immer von der Plattenunterseite, damit die Plattenoberfläche durch die Stichsäge nicht ausfasert. Schalten Sie dazu auch den Pendelhub an Ihrer Stichsäge, sofern vorhanden, aus.

Zum Schutz der Holzteile können Sie rundum die Sockelteile eine Silikonnaht ziehen



Empfohlenes Vorgehen bei der Küchenmontage:

Bohren Sie in den vier Ecken jeweils ein 10-mm-Loch zum leichteren Einsetzen der Stichsäge, und schneiden Sie den Herdausschnitt entlang Ihrer Risse aus. Arbeiten Sie immer von der Plattenunterseite, damit die Plattenoberfläche durch die Stichsäge nicht ausfasert. Schalten Sie dazu auch den Pendelhub an Ihrer Stichsäge, sofern vorhanden, aus.

Zum Schutz der Holzteile können Sie rundum die Sockelteile eine Silikonnaht ziehen



I



C5 x2

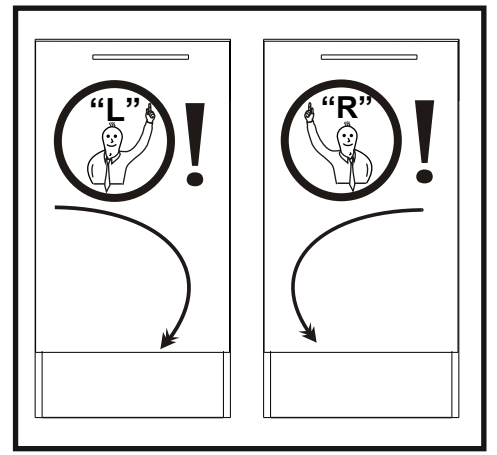

C

C2

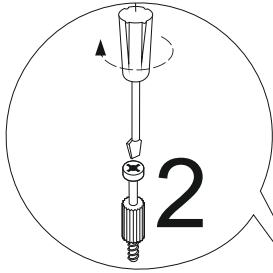

C3

C4

C6

10A

10A

10A

10A

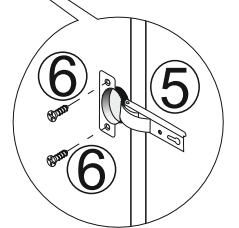
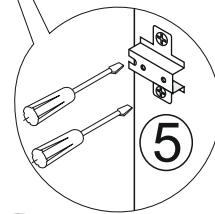

C1

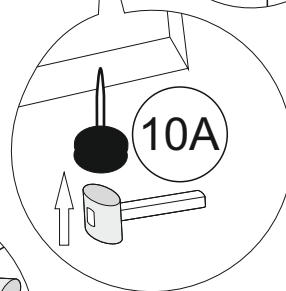
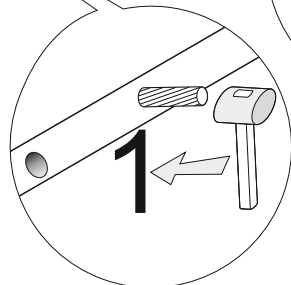

II

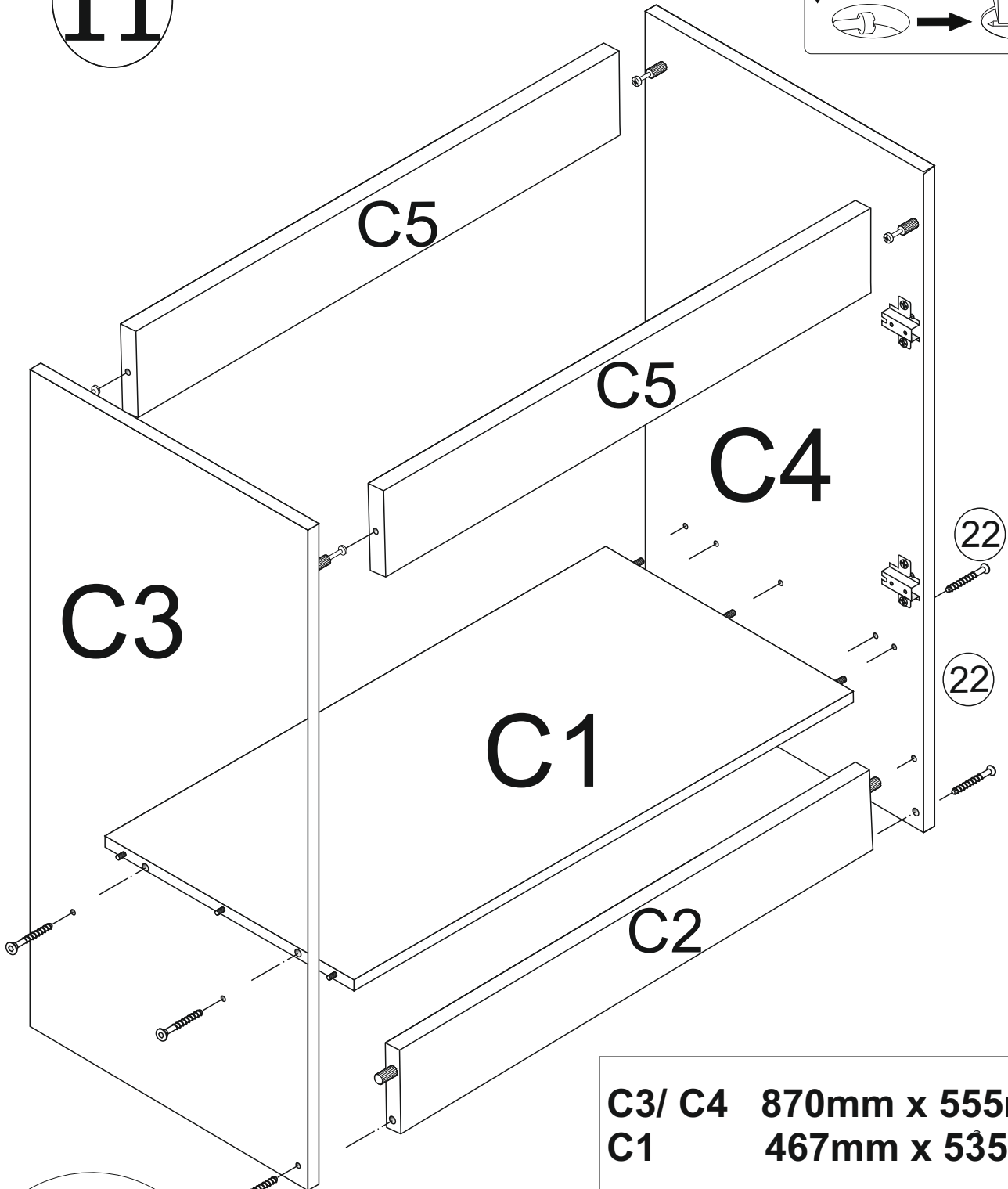
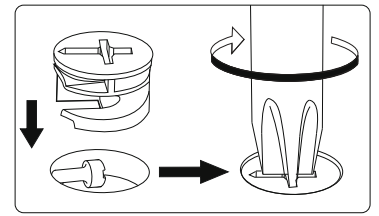

C3/ C4	870mm x 555mm
C1	467mm x 535mm

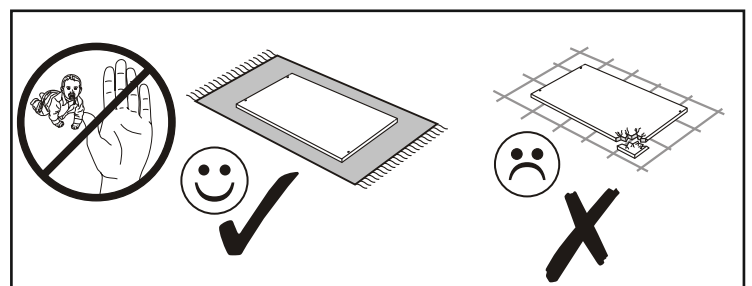
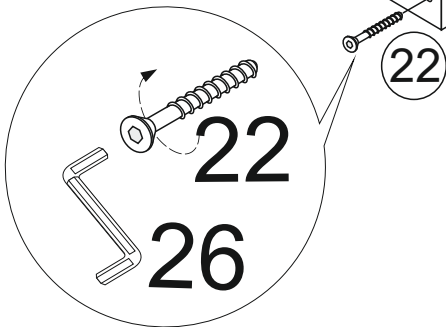

III

C5 467mm x 74mm
C6 713mm x 496mm
C2 467mm x 150mm

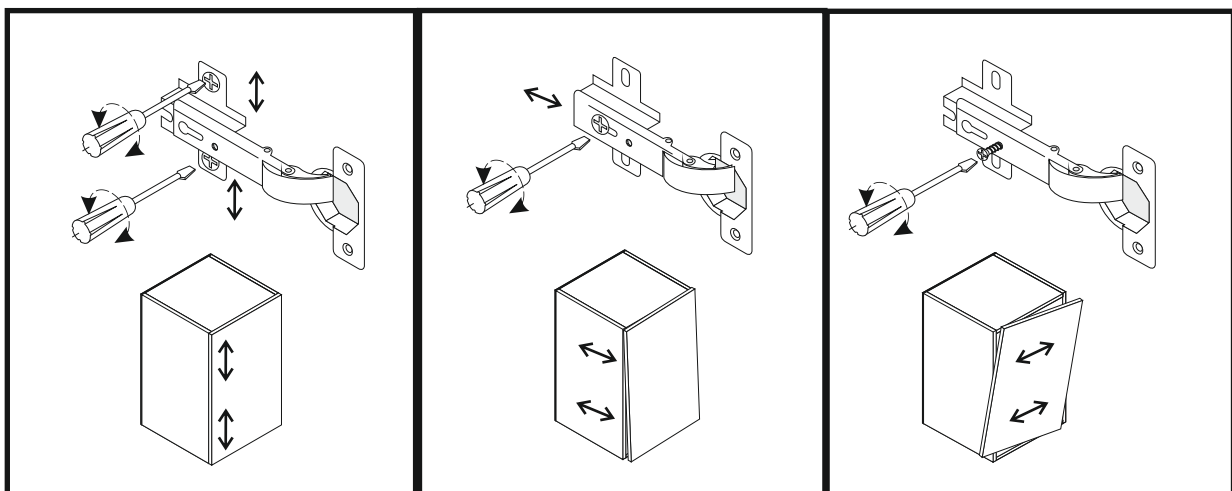
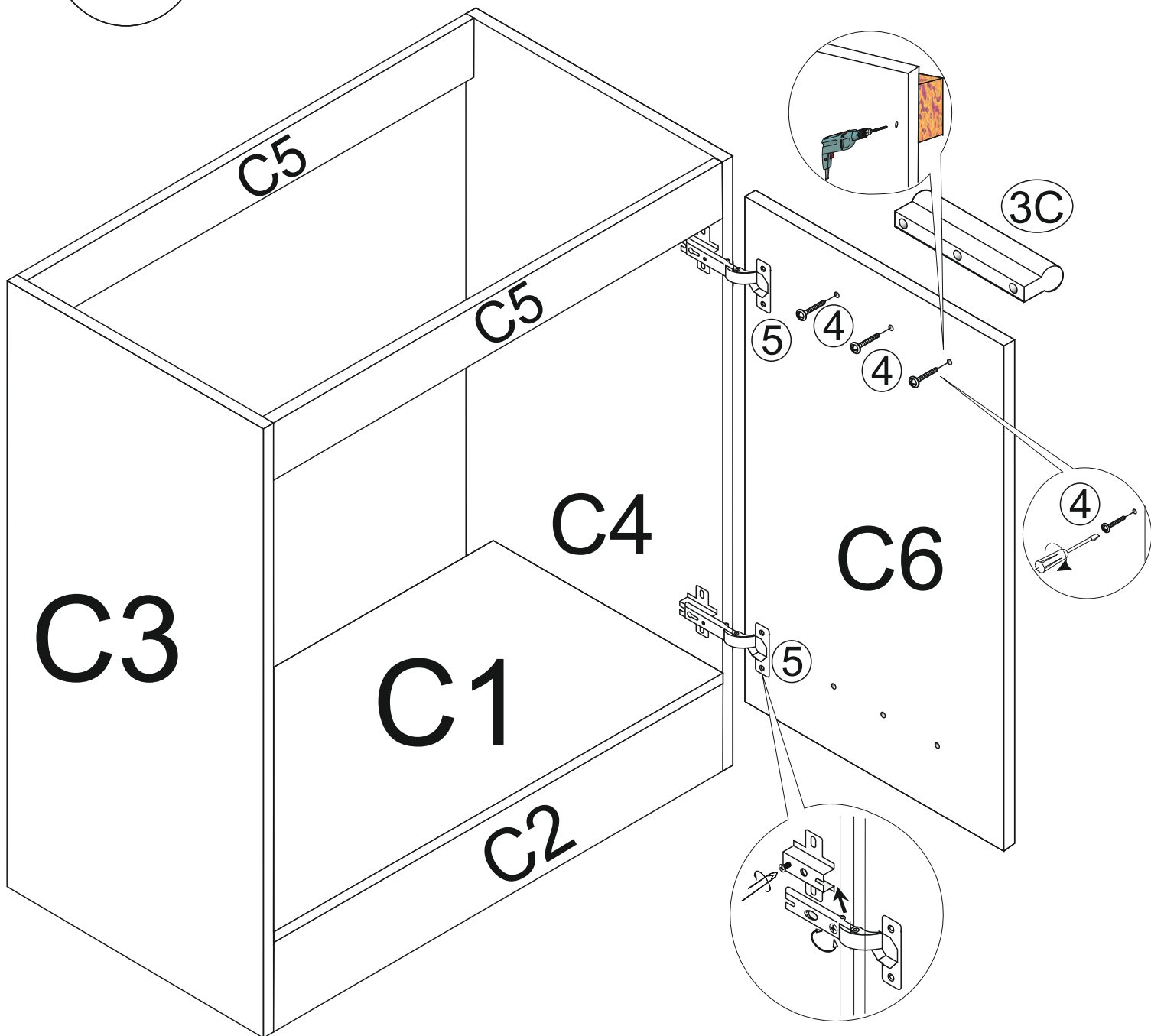

I

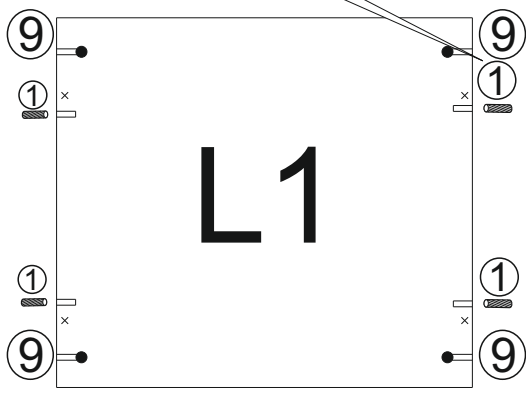
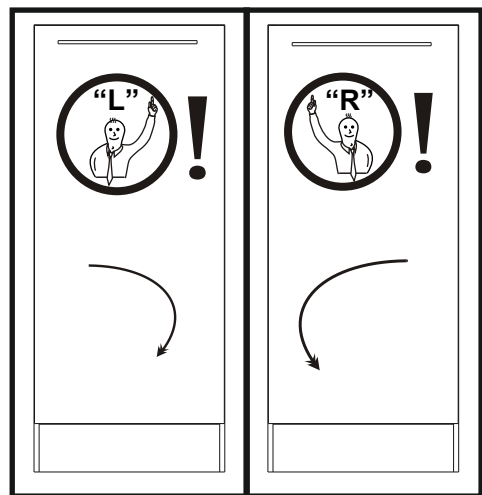
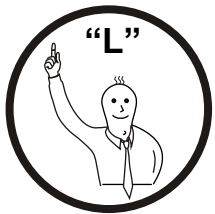
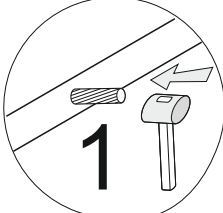

L

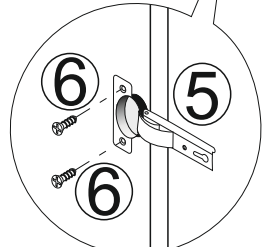
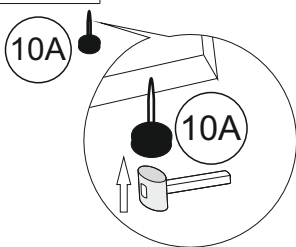
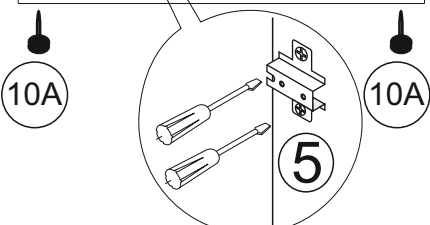
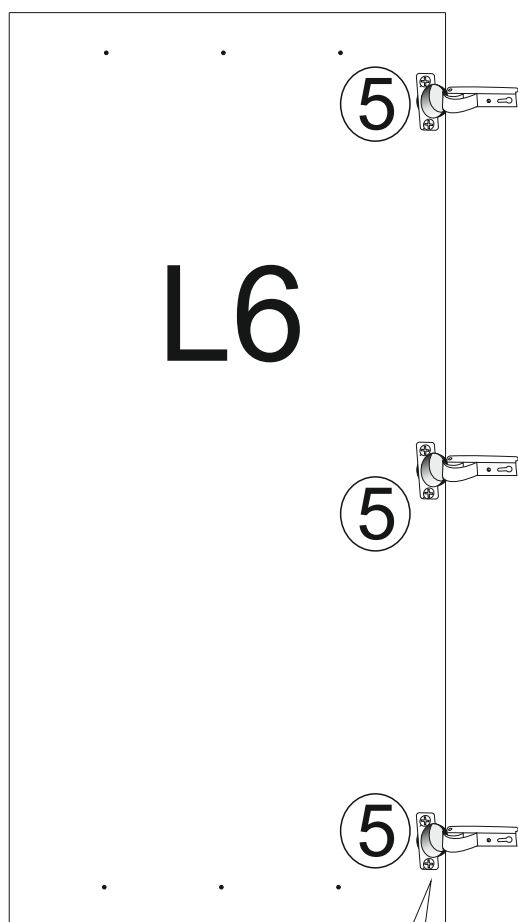
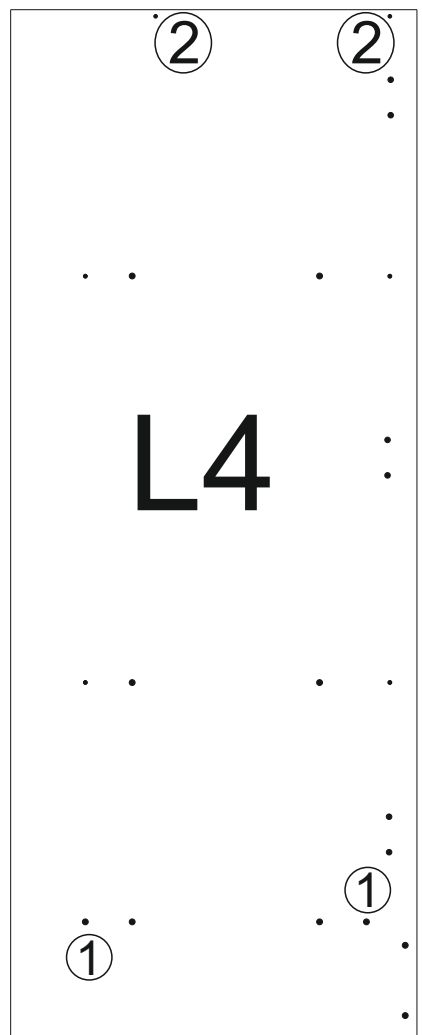
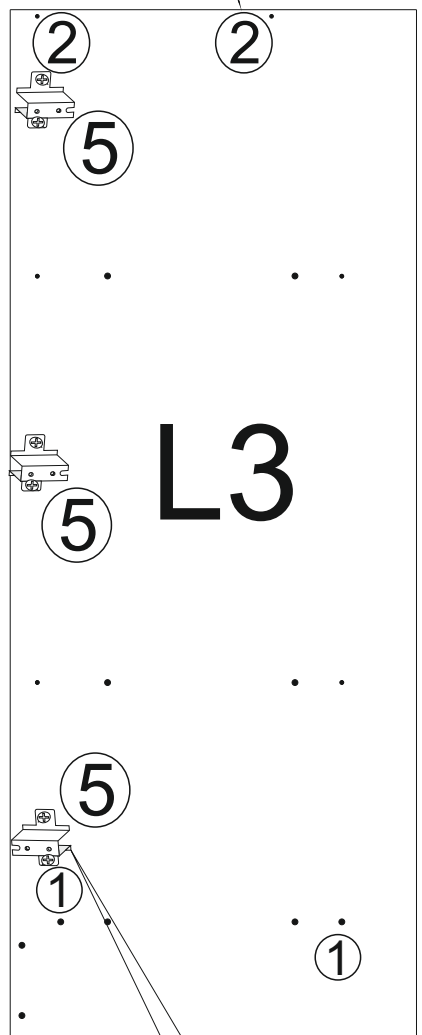
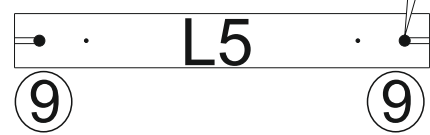
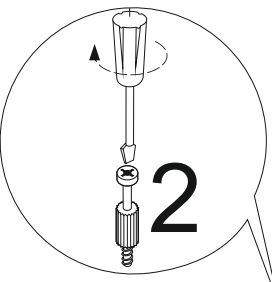

OPTION 1



II

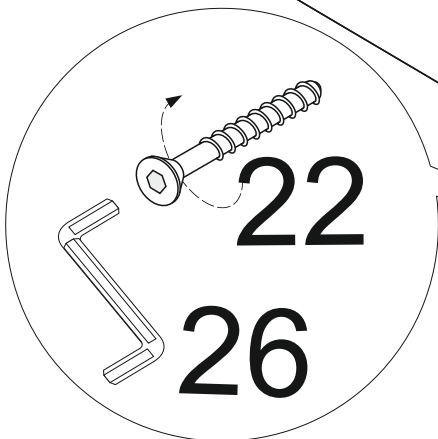
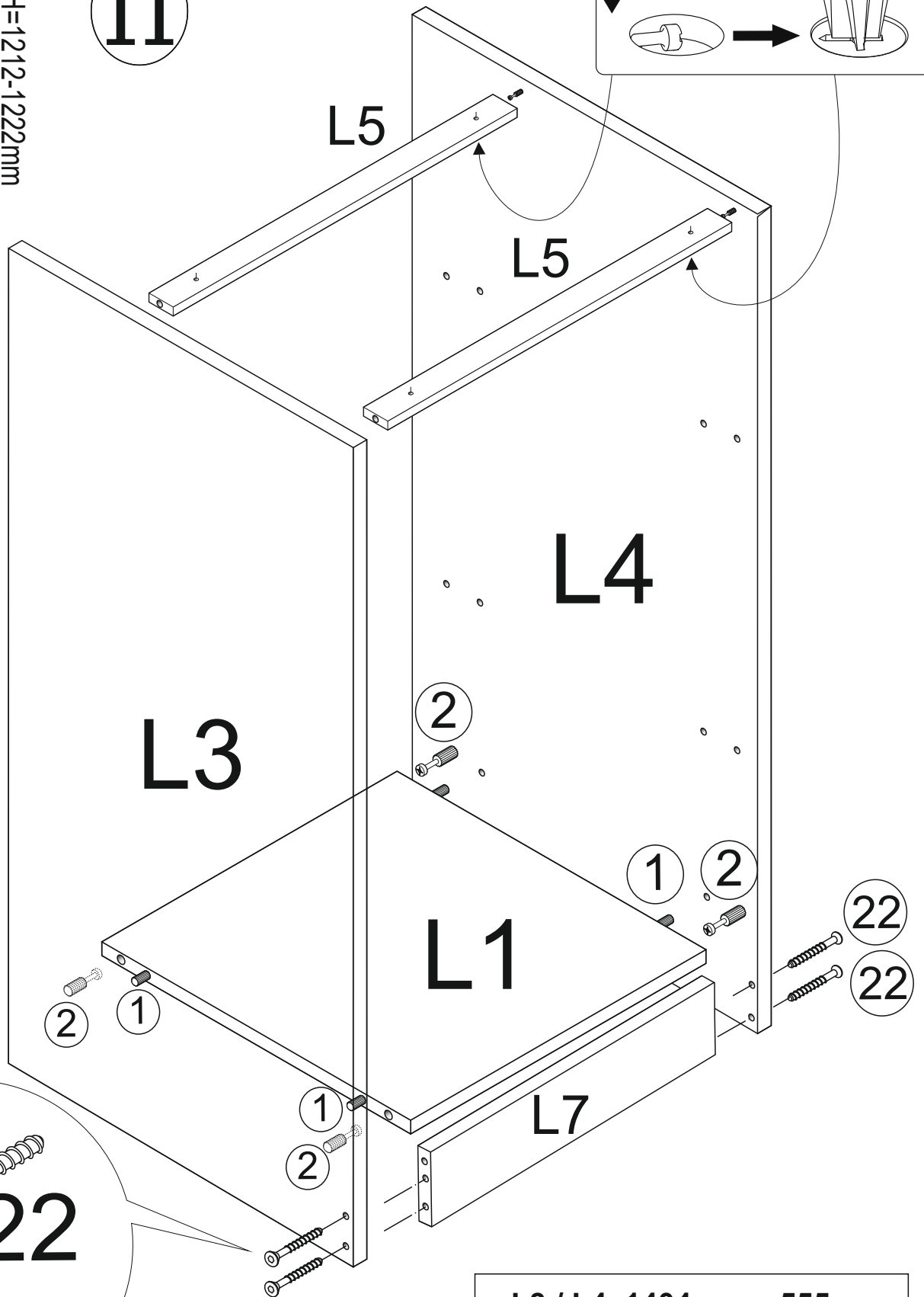
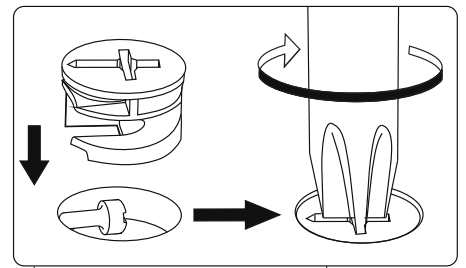

L3 / L4	1404mm x 555mm
L1	567mm x 510mm
L5	567mm x 74mm
L7	567mm x 150mm

III

OPTION 1

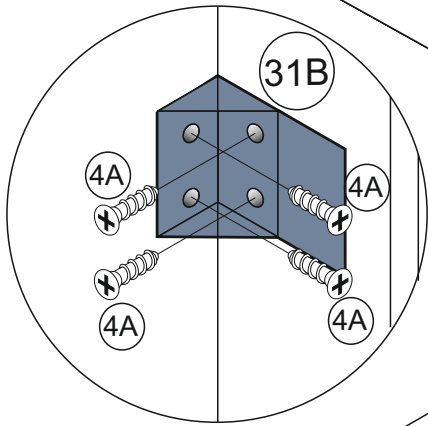
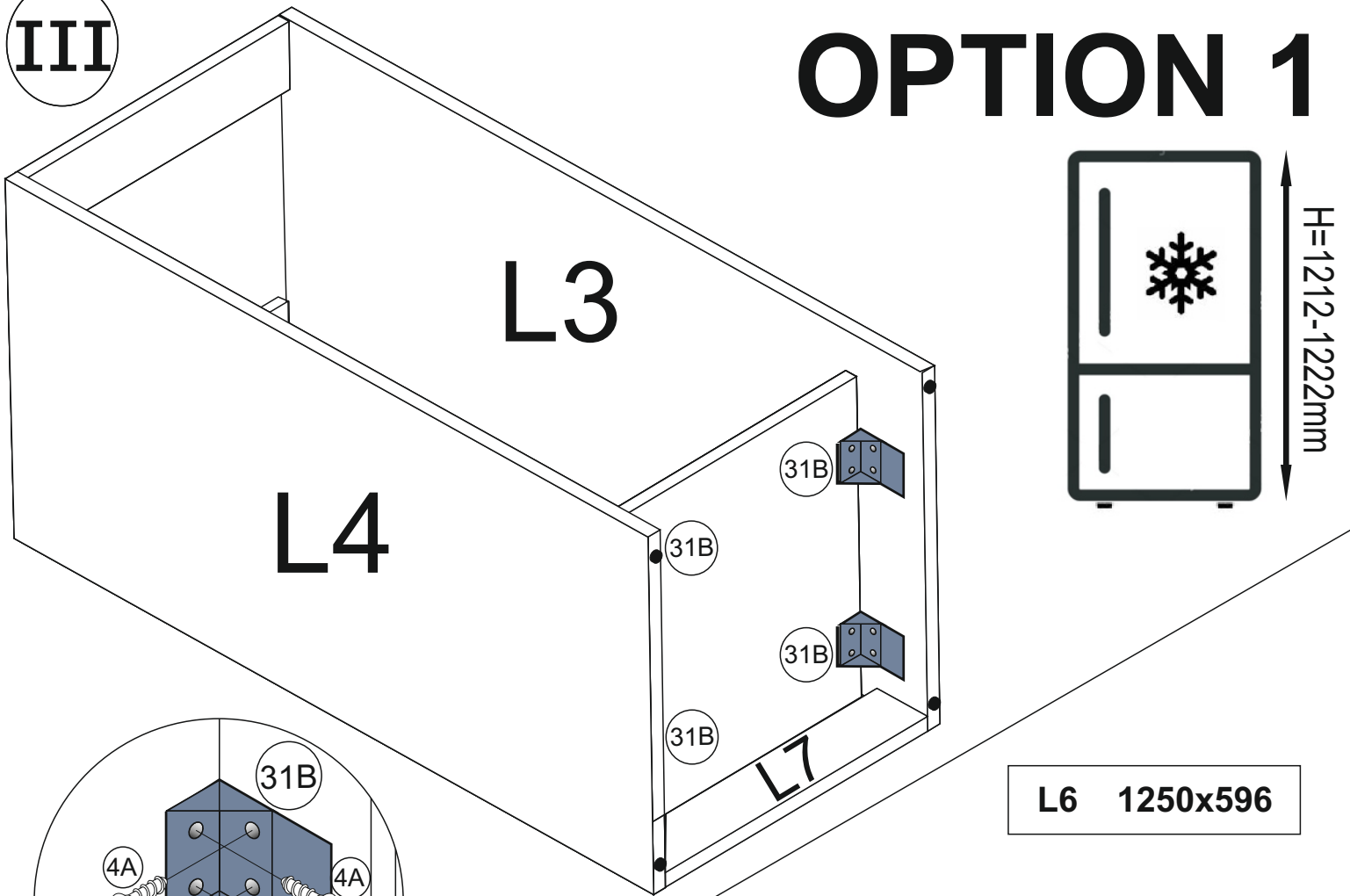

IV

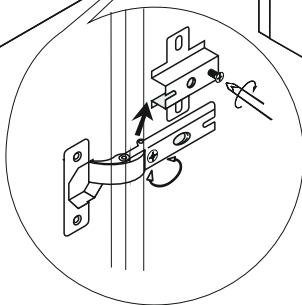
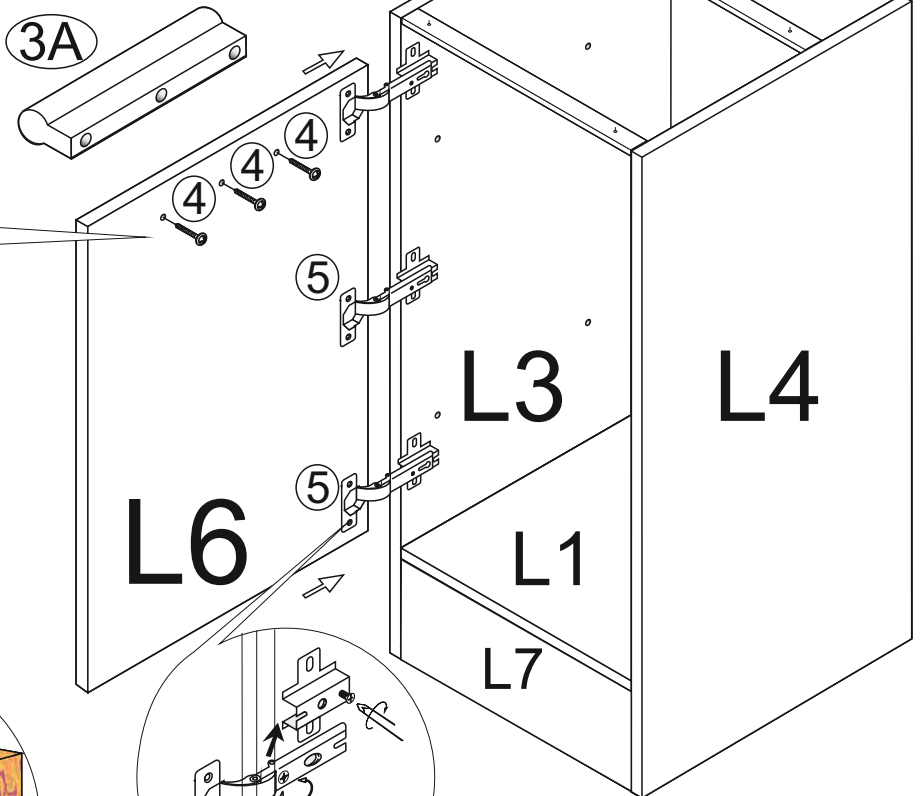
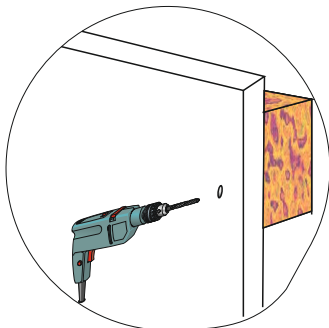
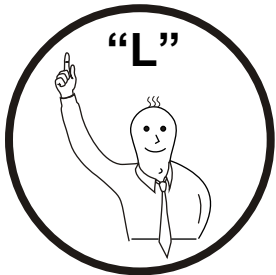
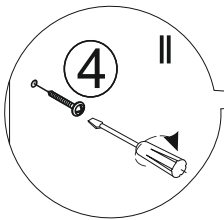

OPTION 2

III

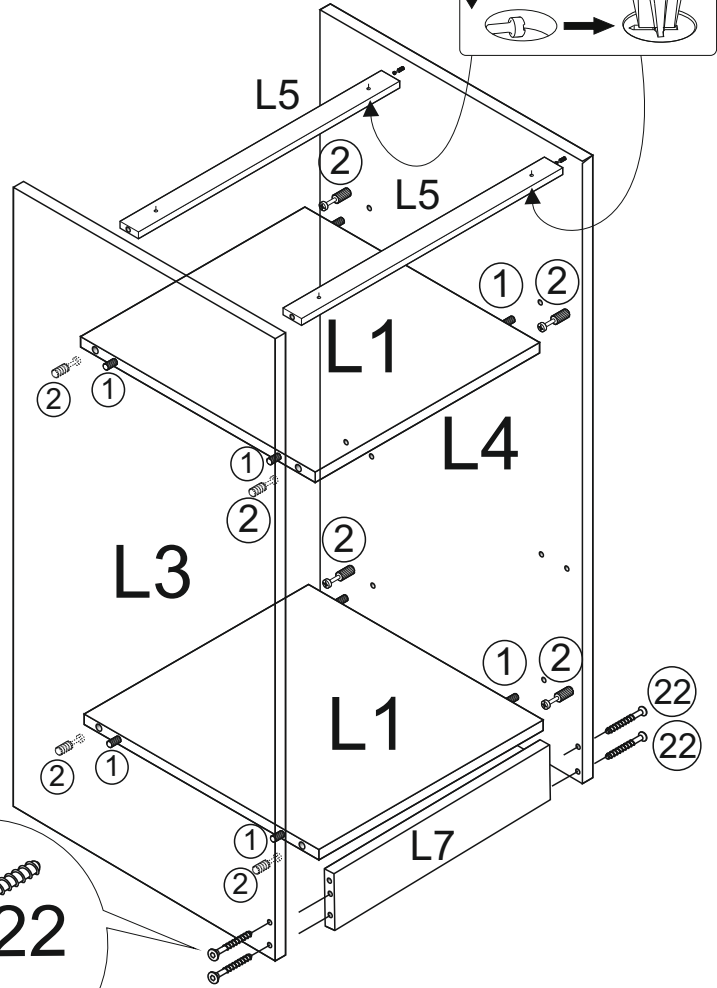
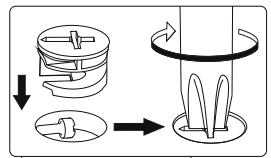
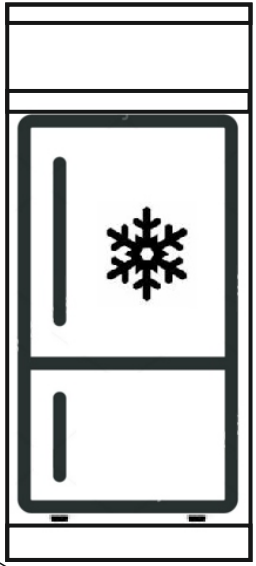

IV

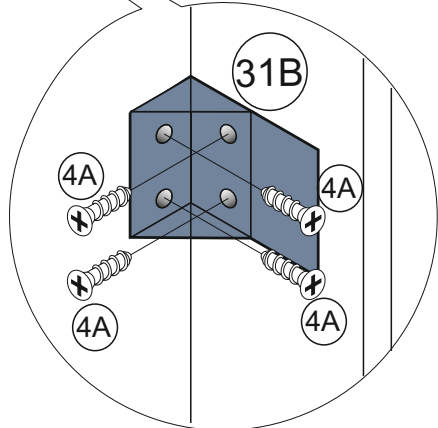
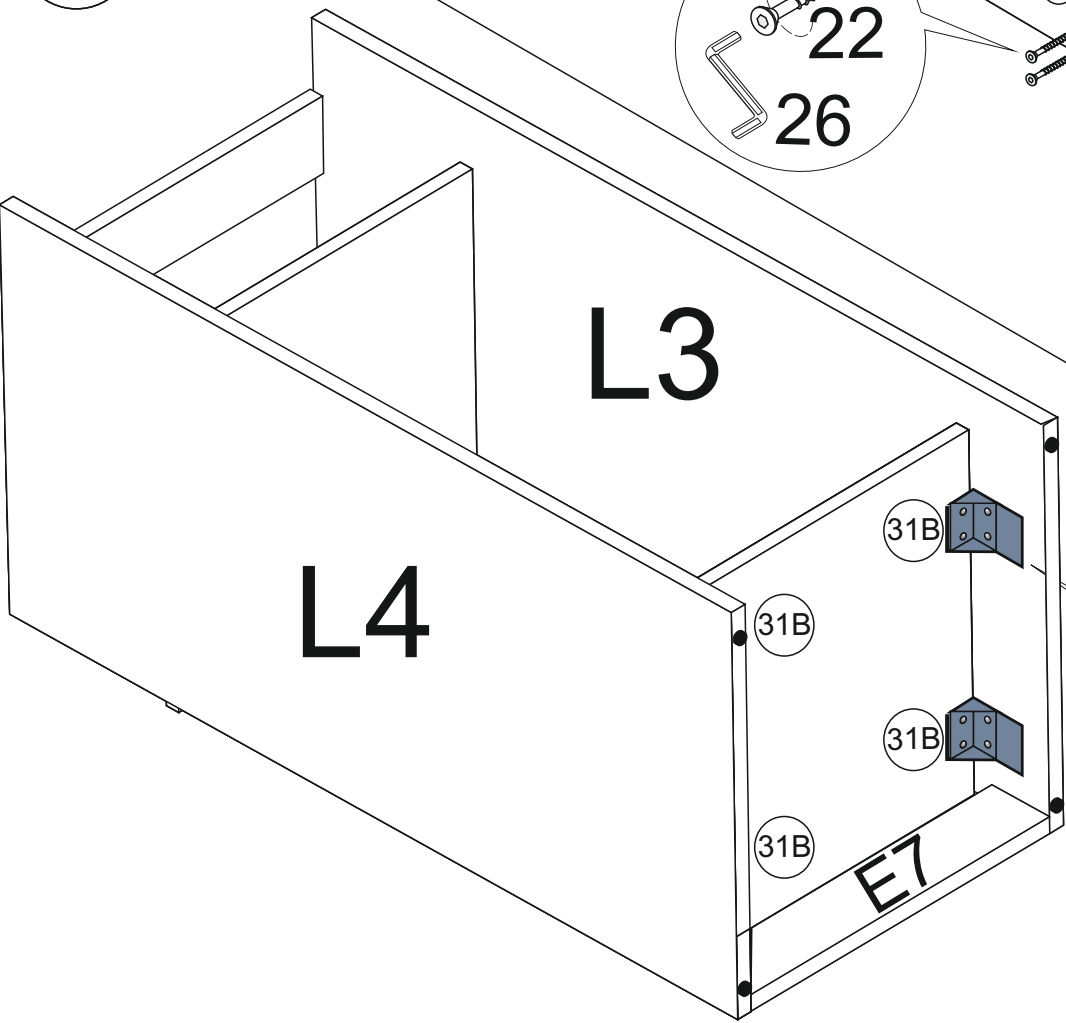

V

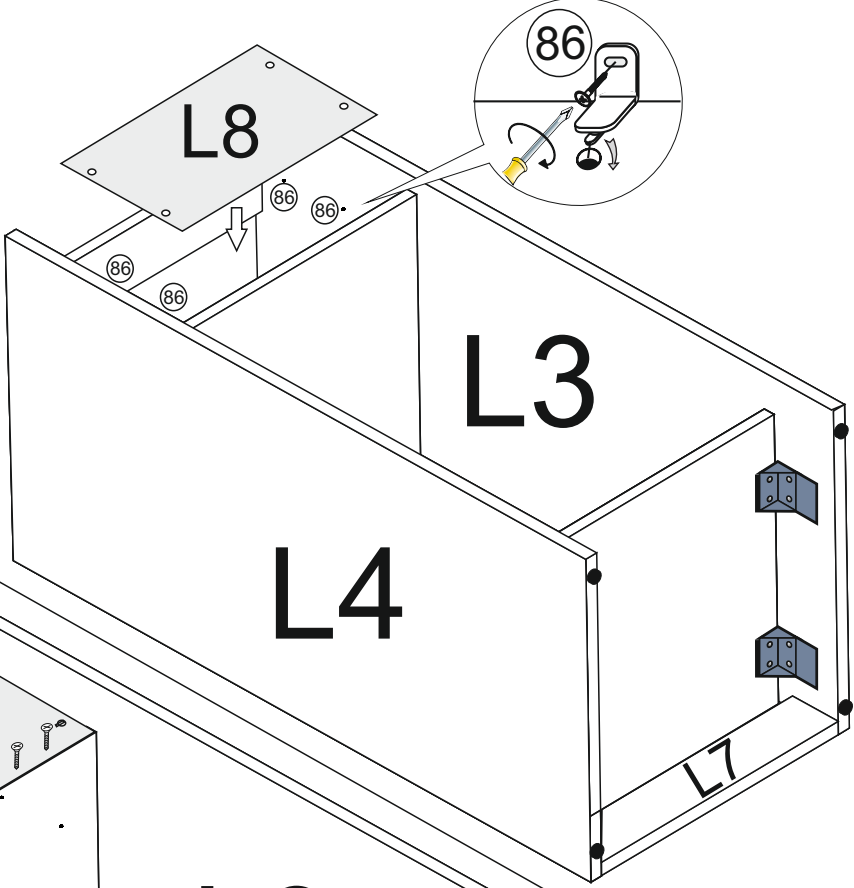

VI

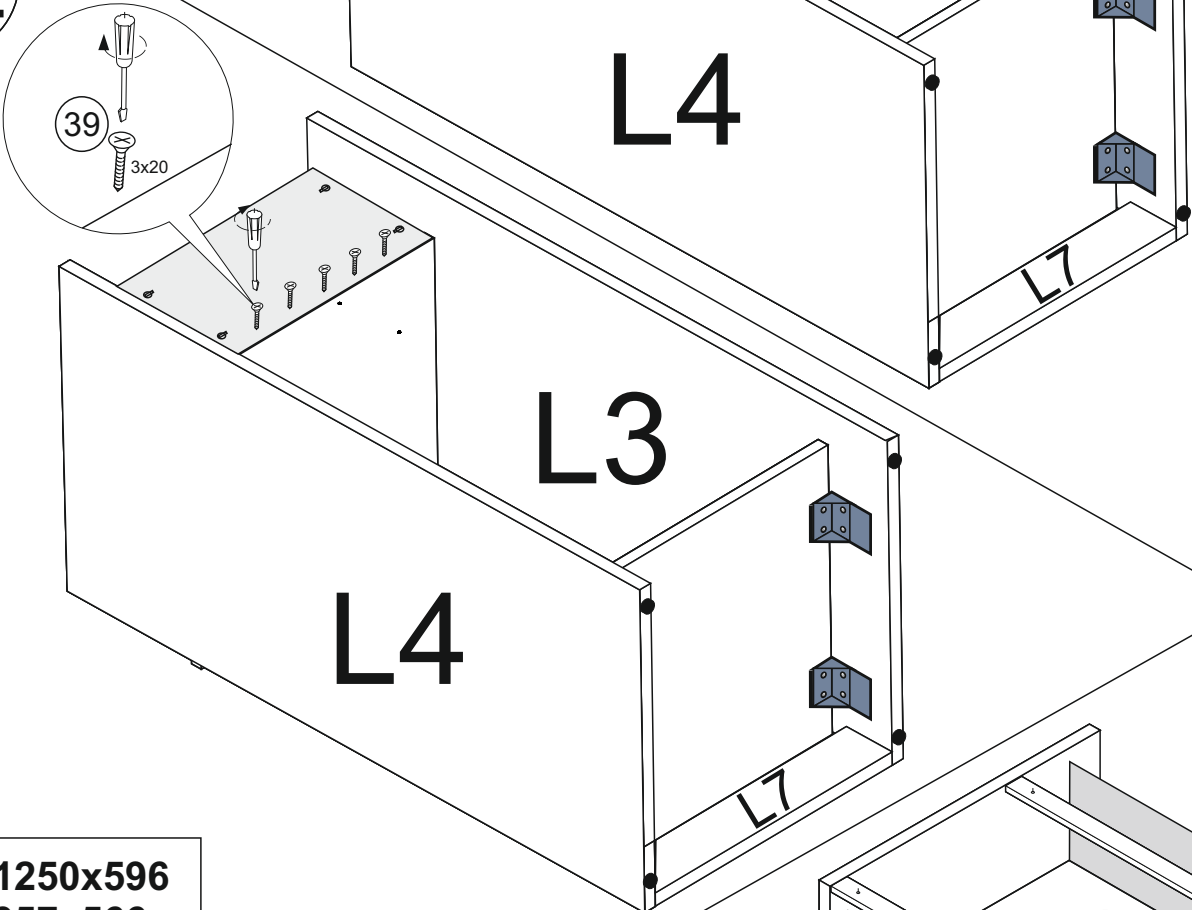

L6	1250x596
L8	357x566

VII

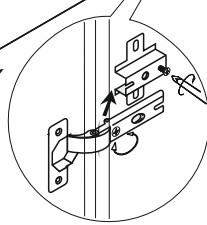
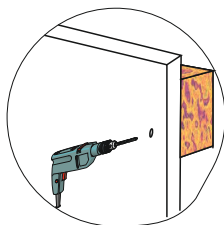
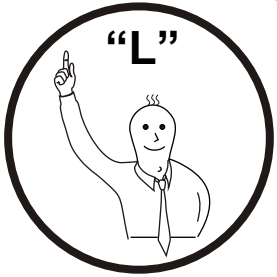
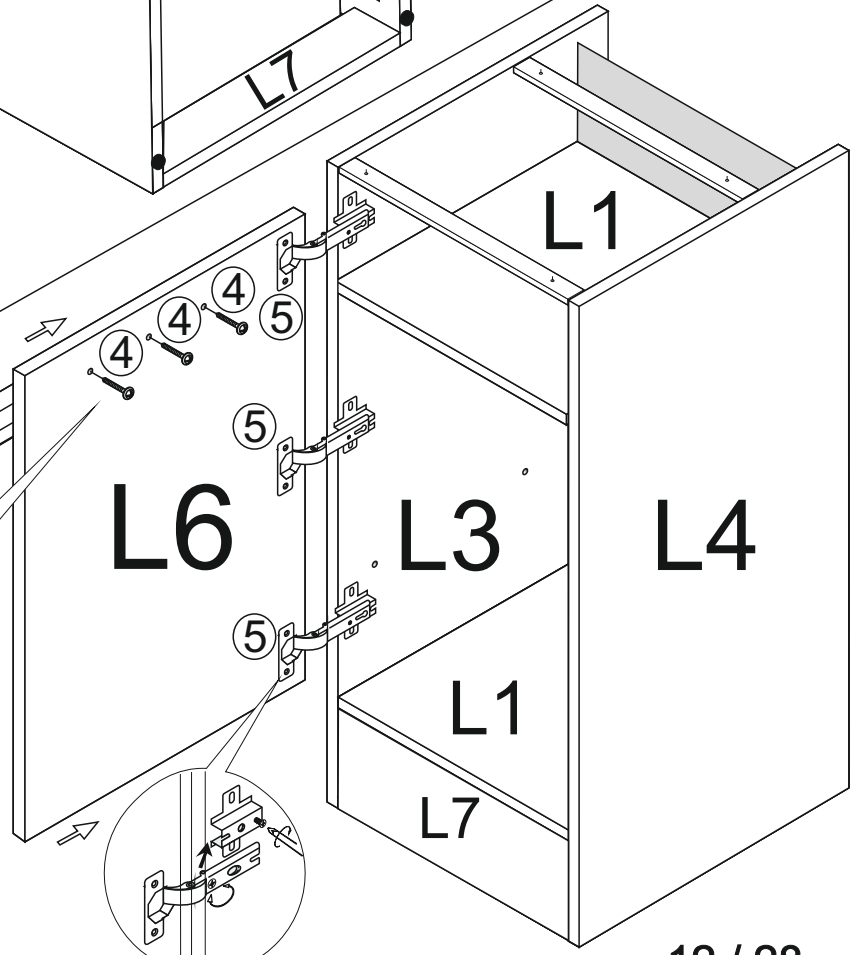
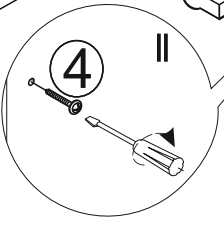

OPTION 3

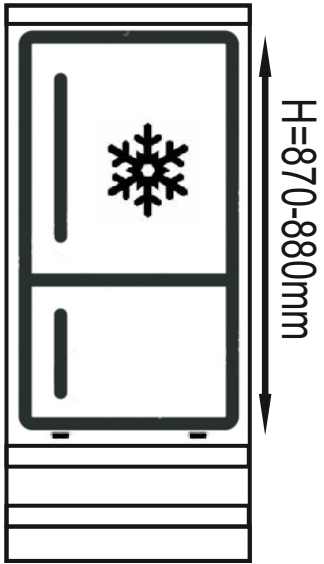

III

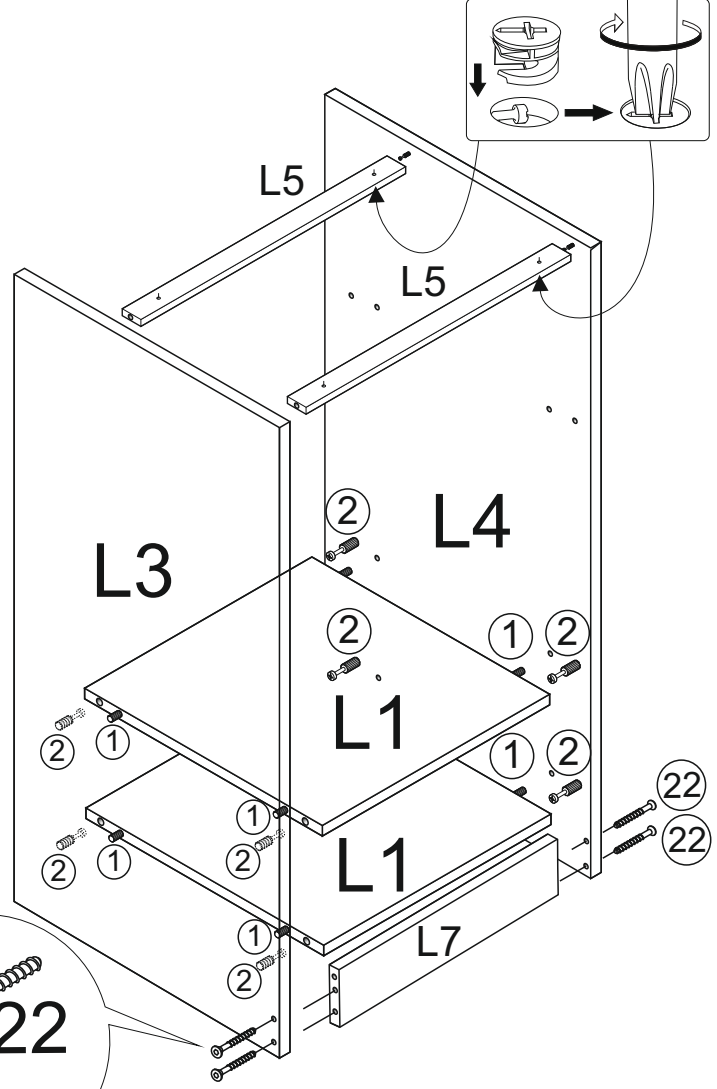

IV

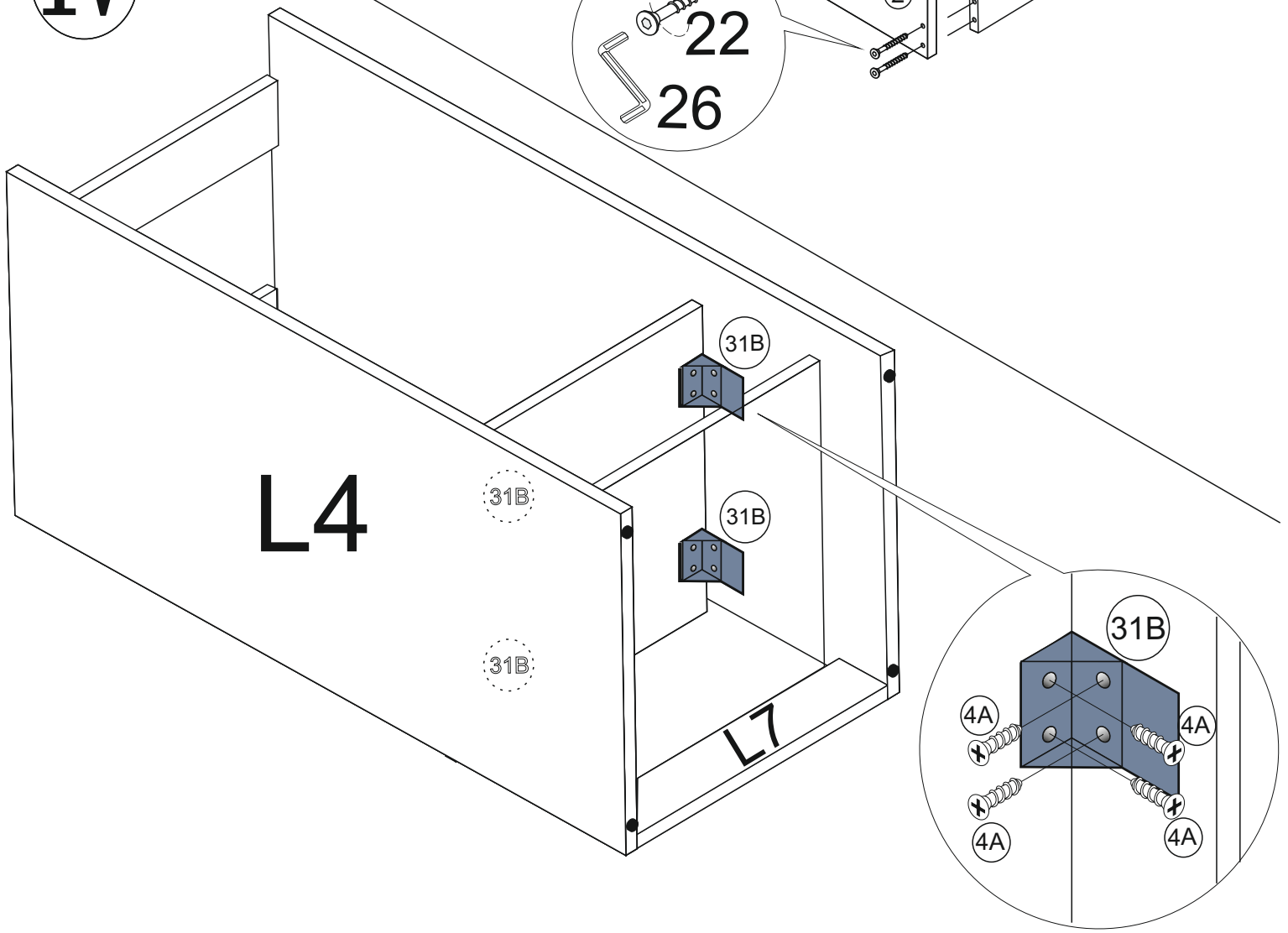

V

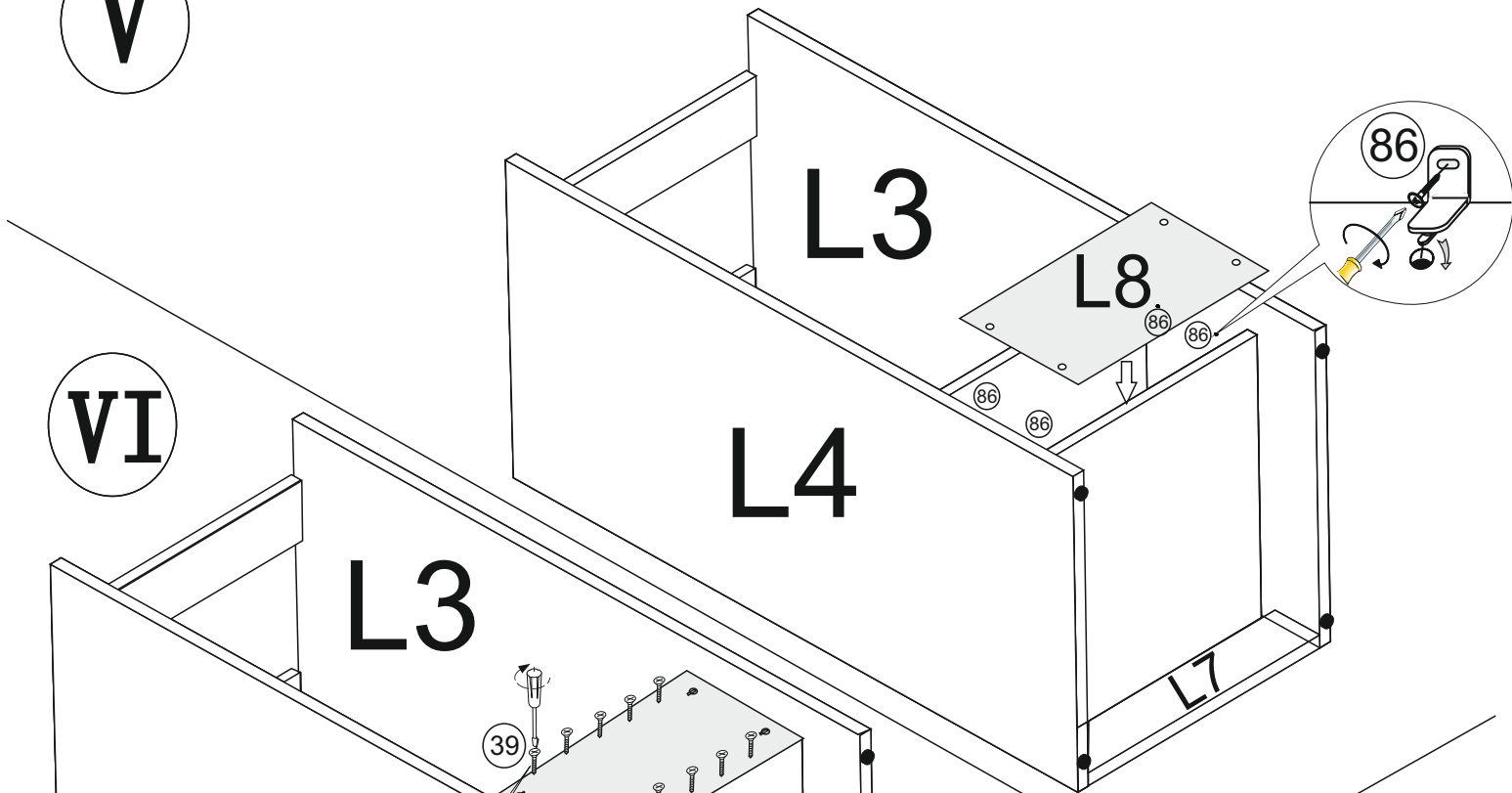

VI

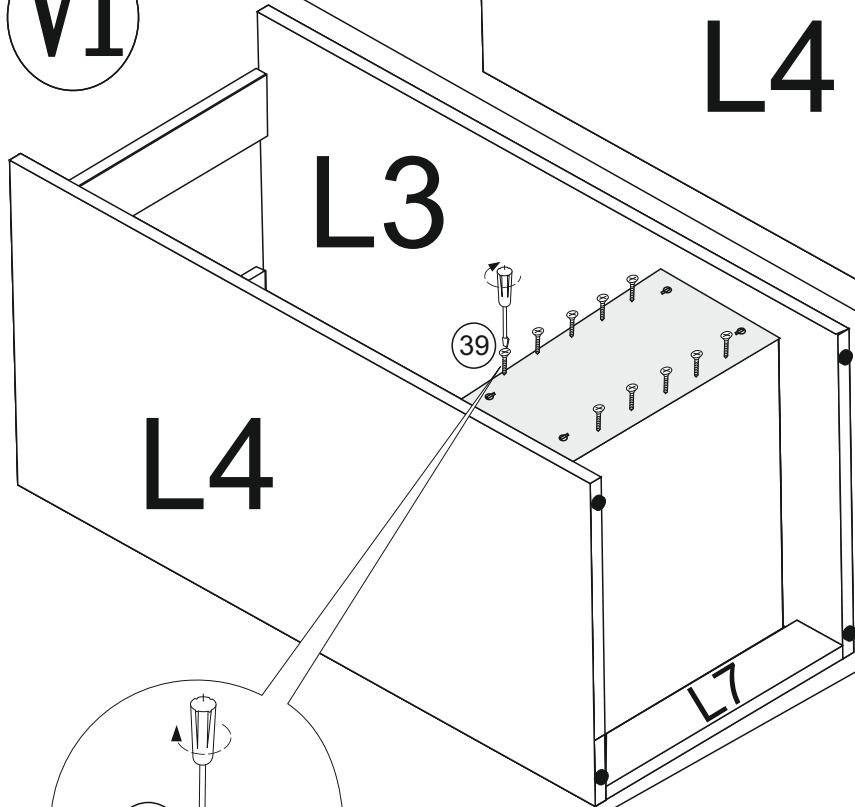

L6	1250x596
L8	357x566

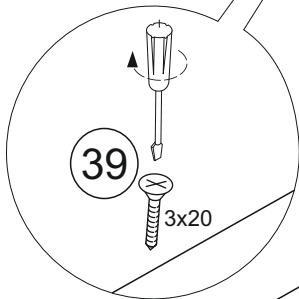

VII

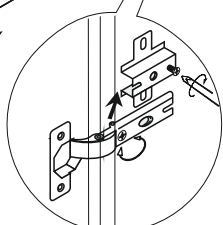
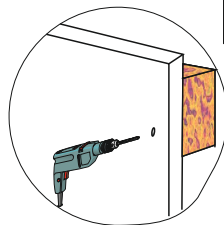
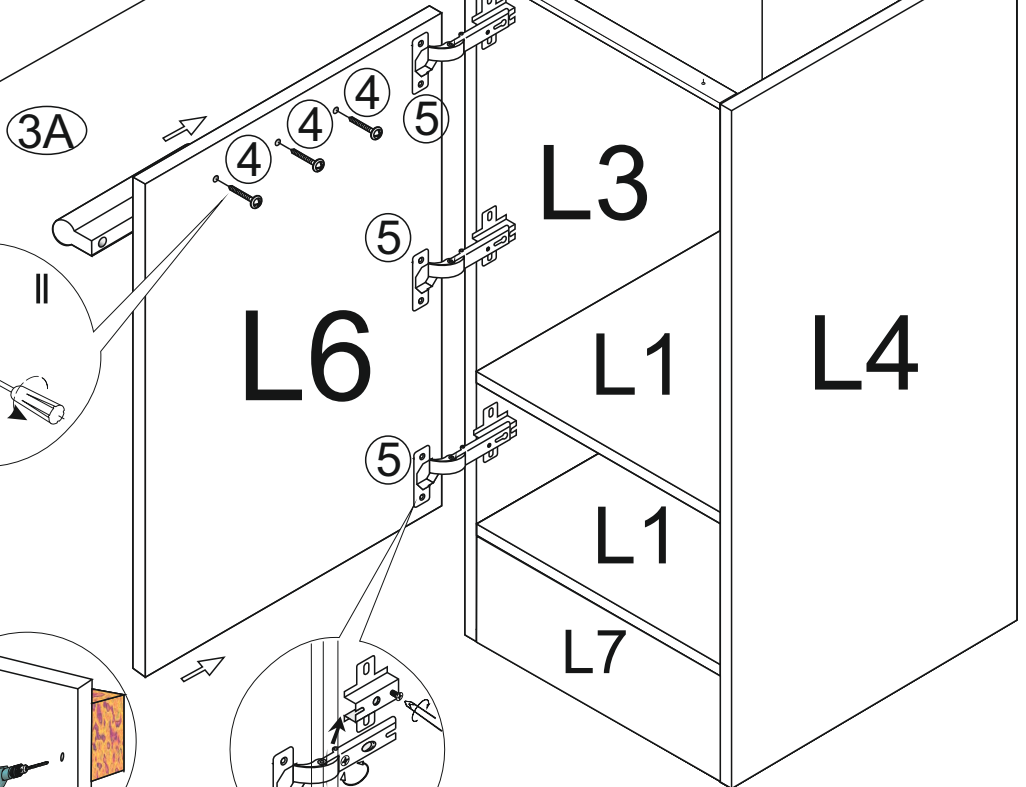
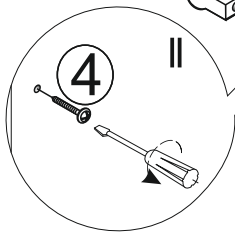

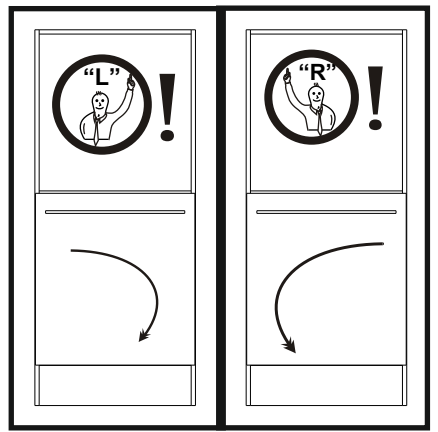
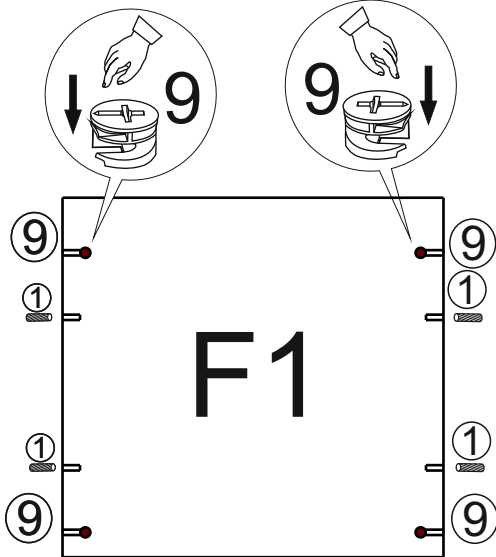
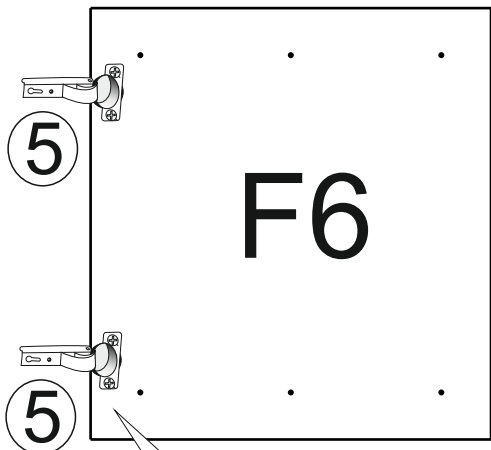

F

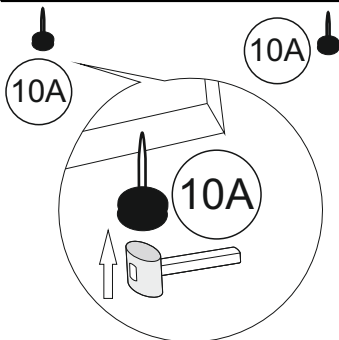
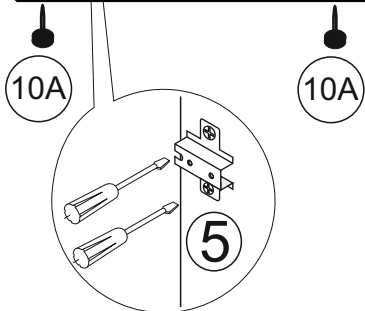
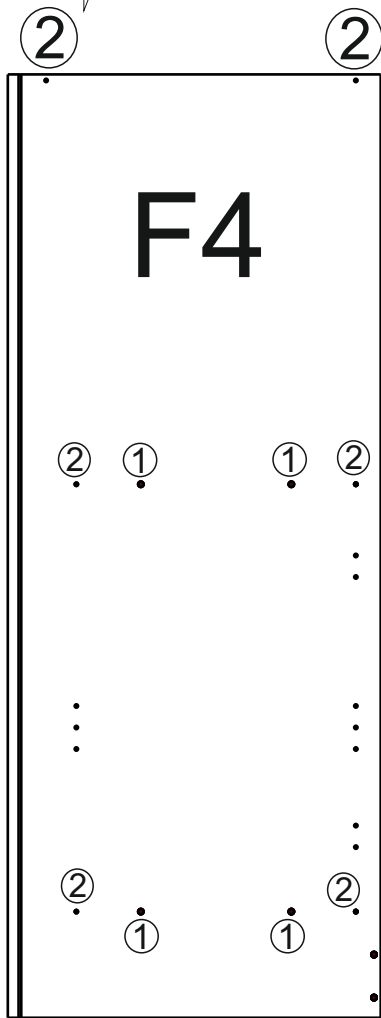
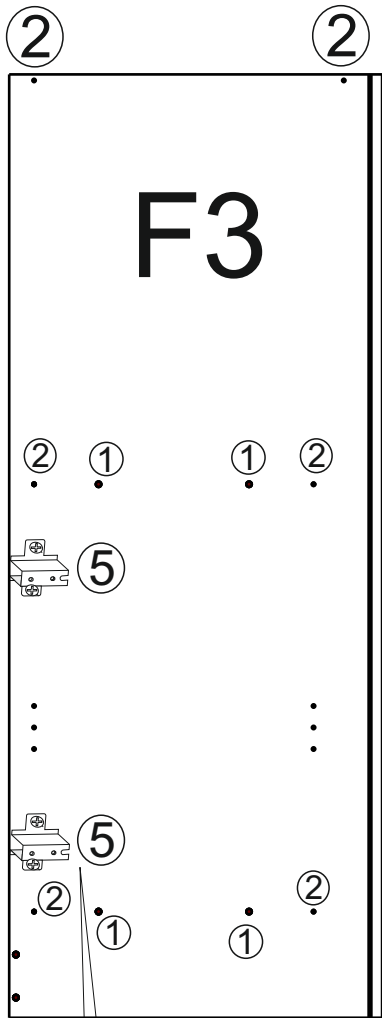
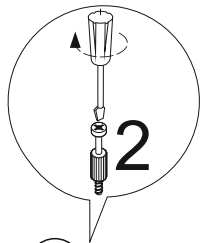
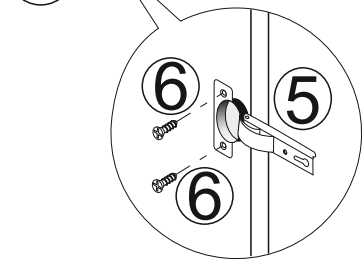

II

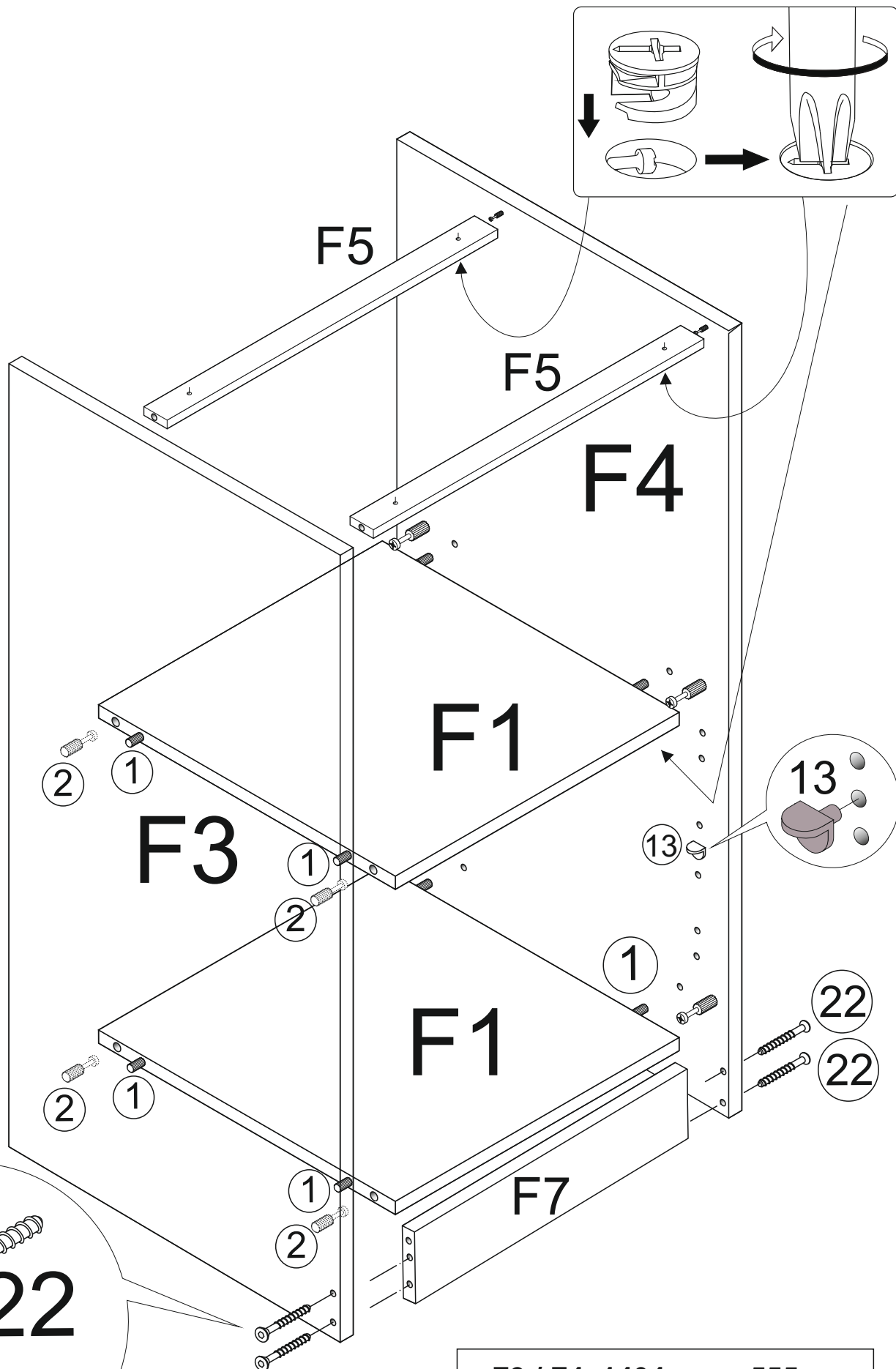

F3 / F4	1404mm x 555mm
F1	567mm x 535mm
F5	567mm x 74mm
F7	567mm x 150mm

III

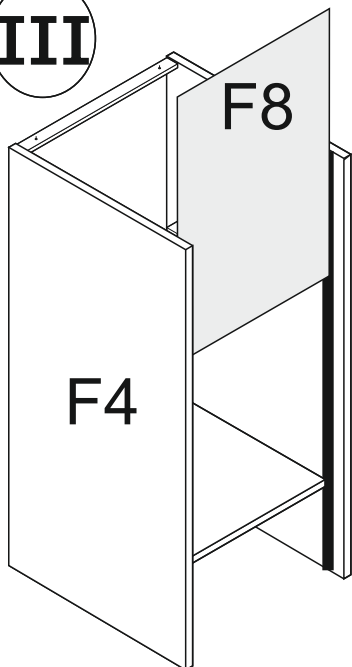

IV

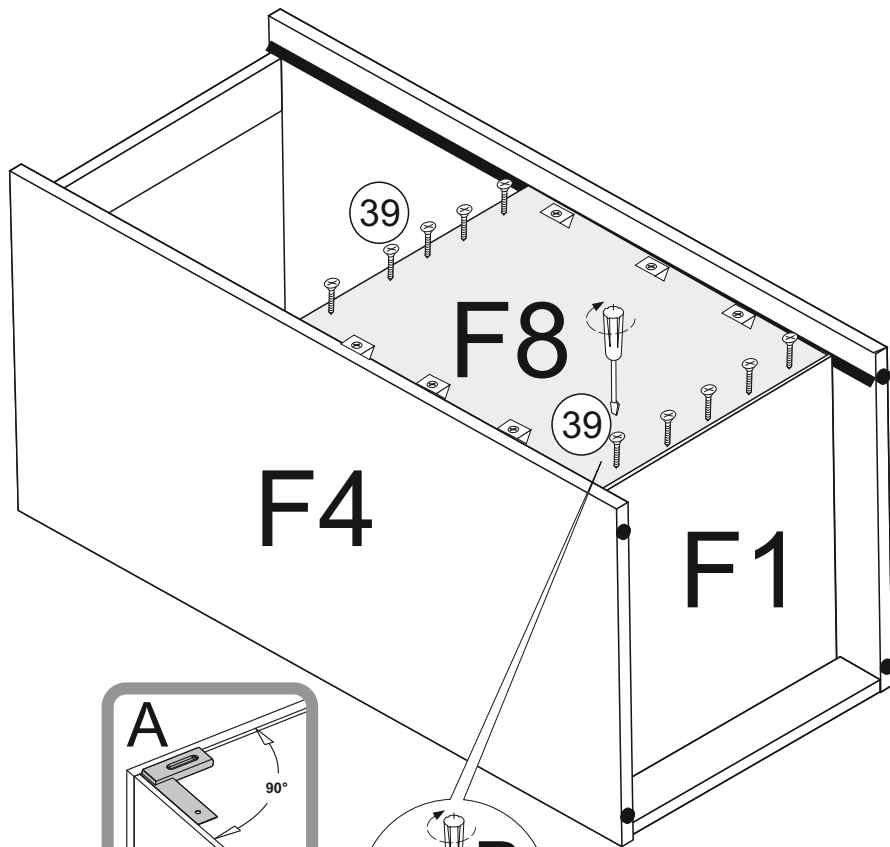

V

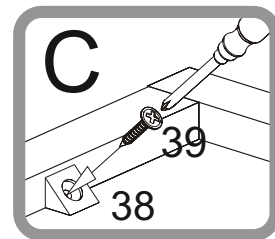
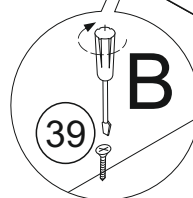
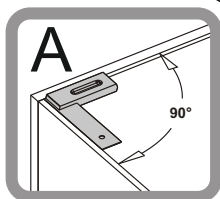
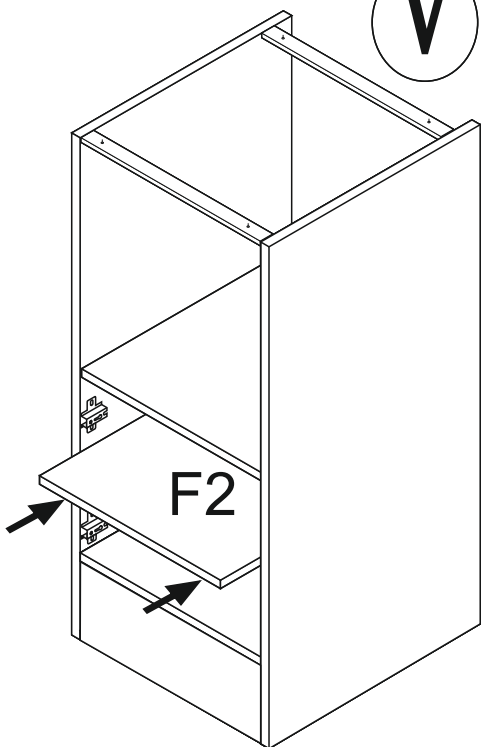

F2	567x510
F6	642x596
F8	650x577

VI

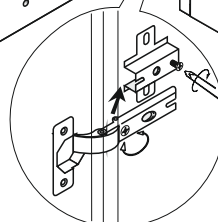
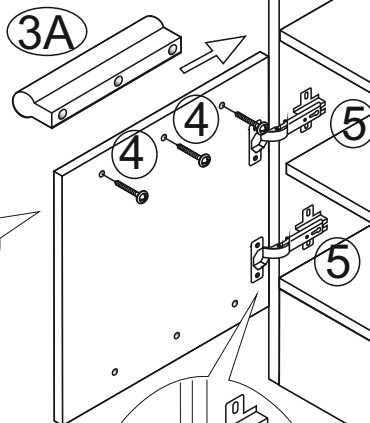
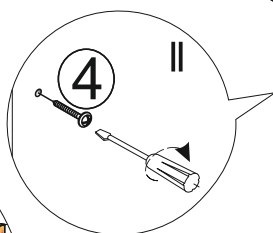
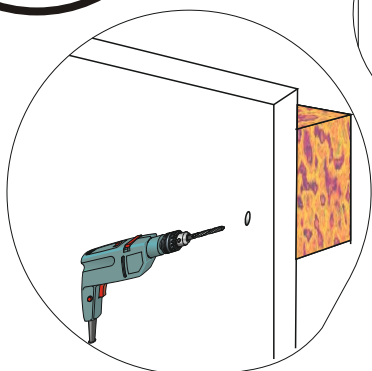
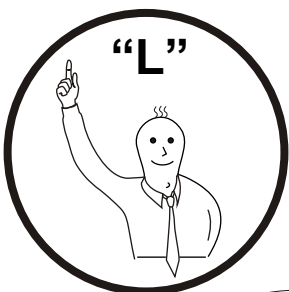

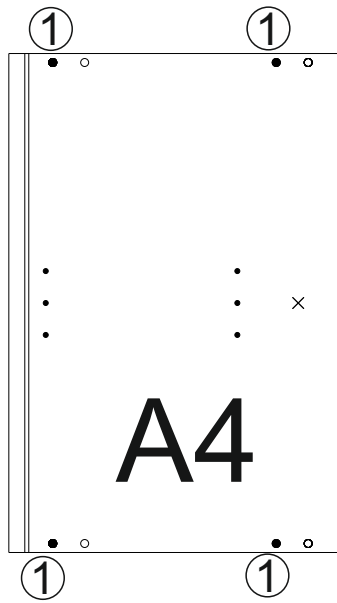
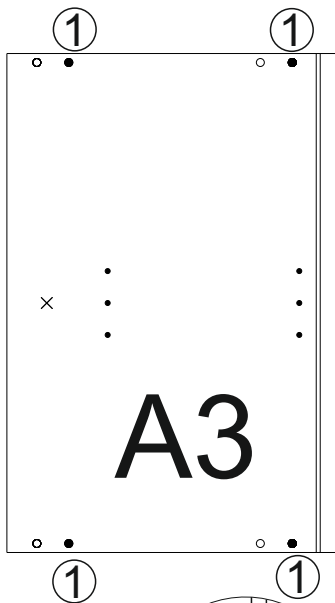

I

A

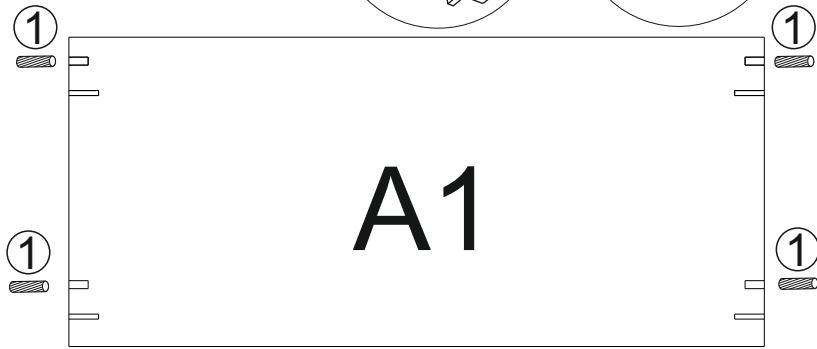
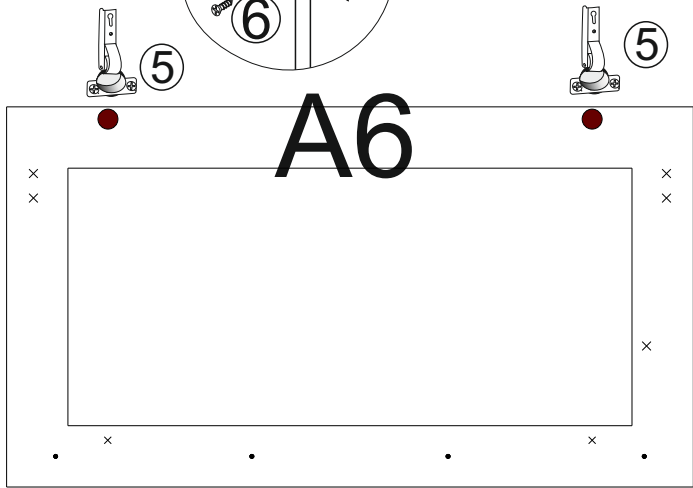
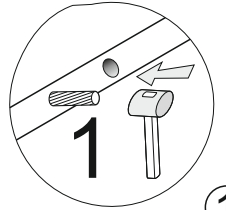
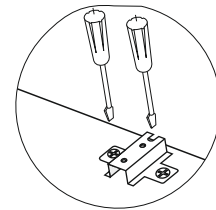
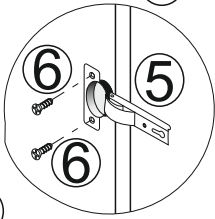
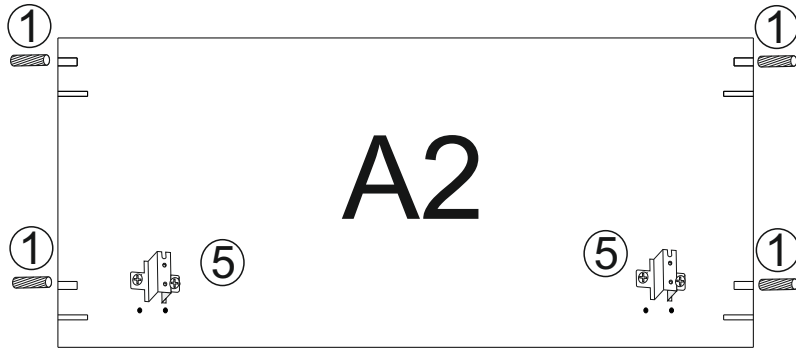
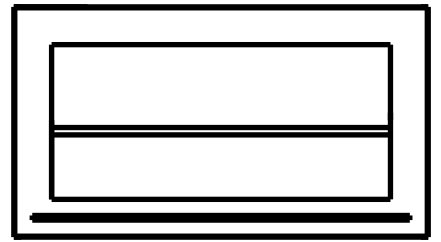

II

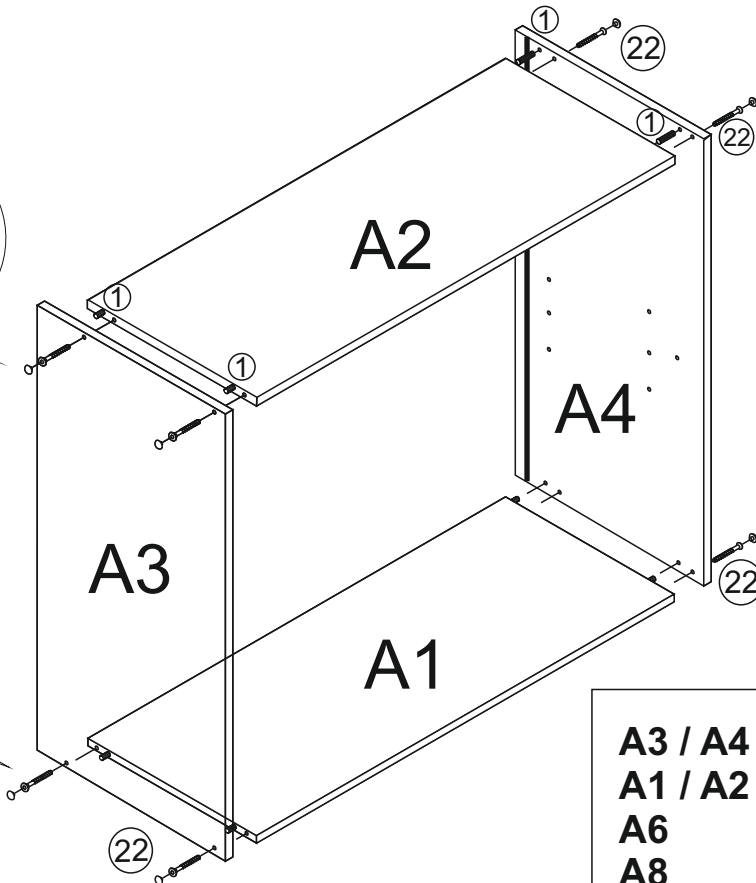
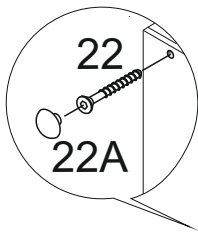

A3 / A4	500mm x 330mm
A1 / A2	867mm x 310mm
A6	896mm x 496mm
A8	495mm x 877mm

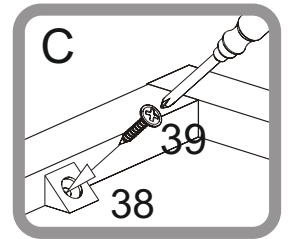
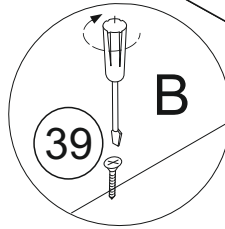
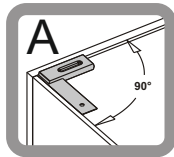
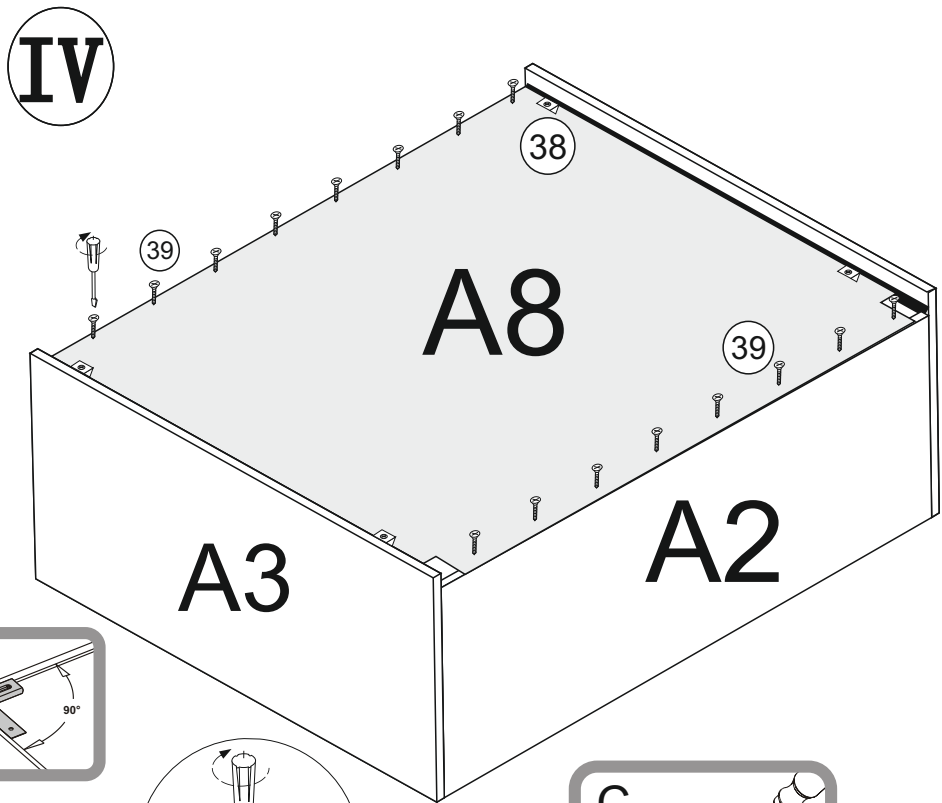
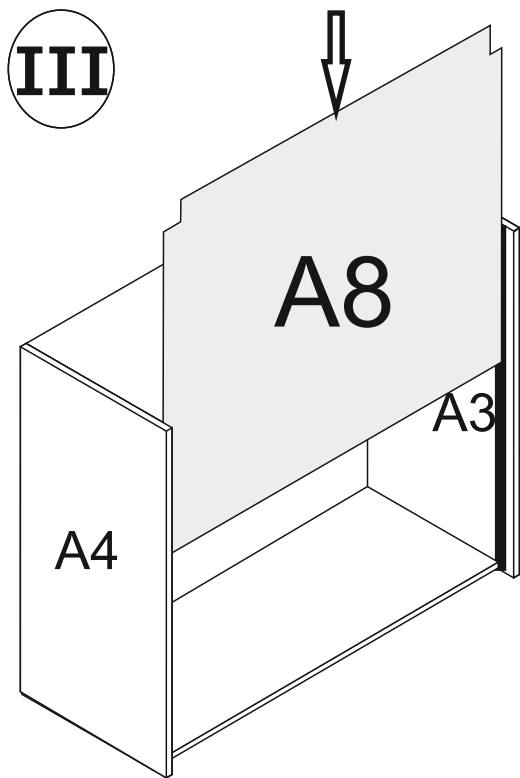

V

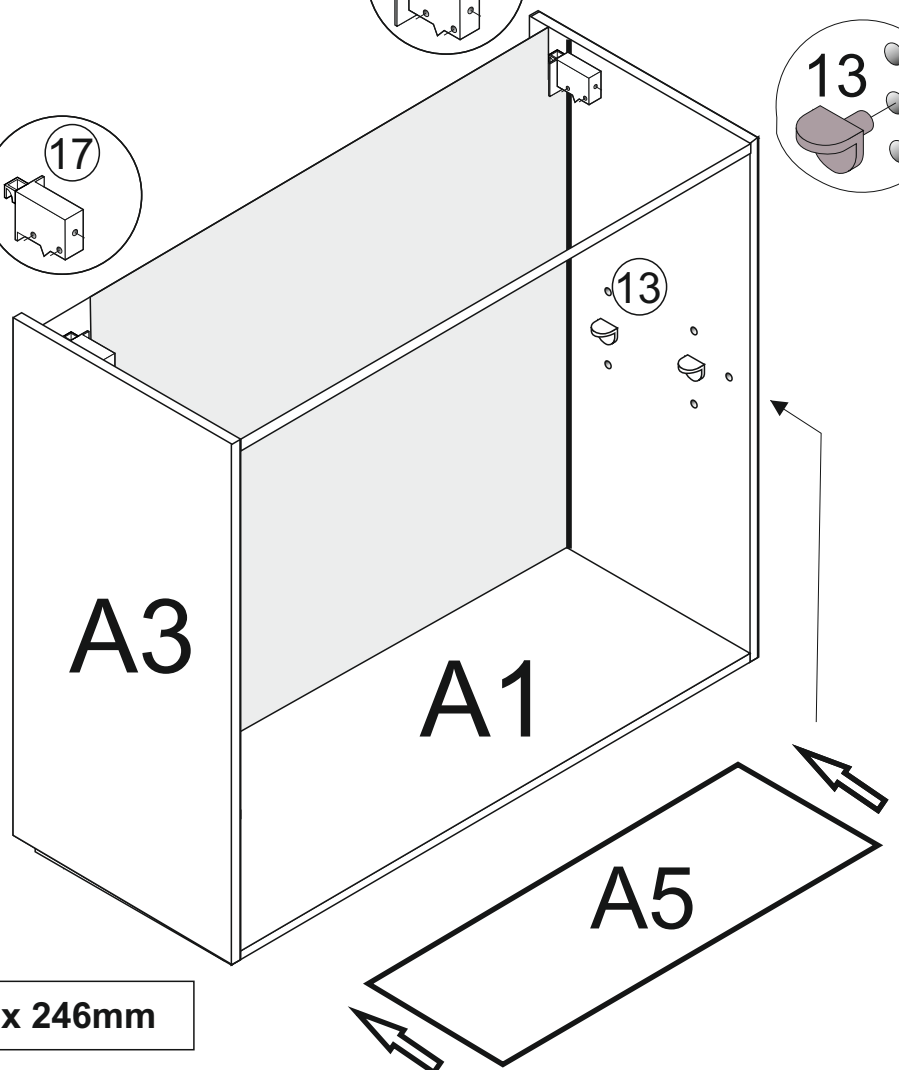
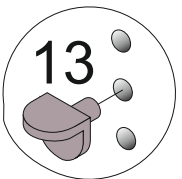
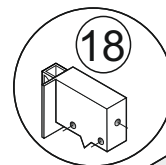
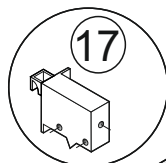
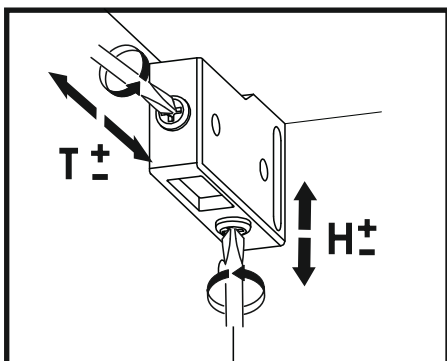
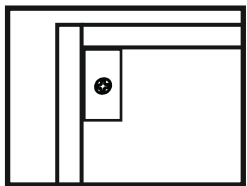
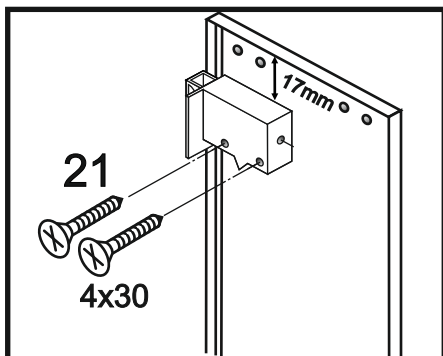

A5 867mm x 246mm

VI

A7 766mm x 366mm

A7

A6

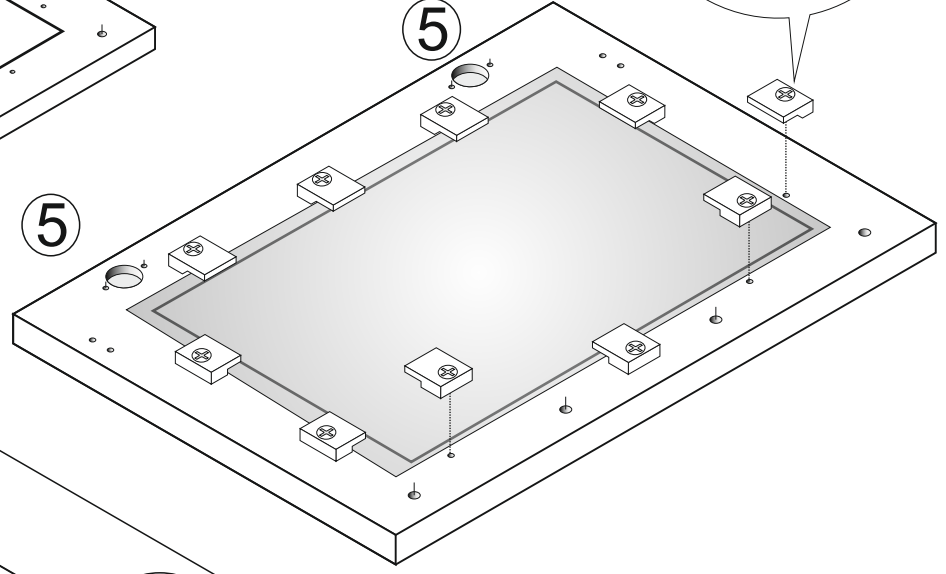
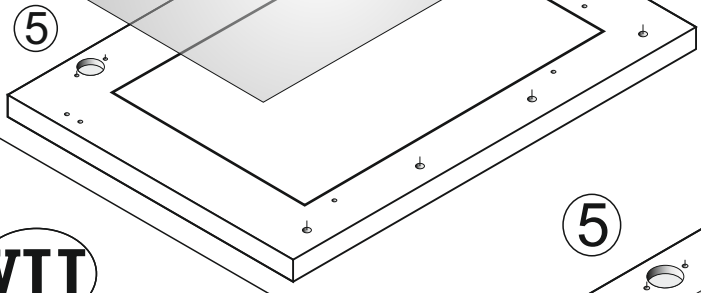
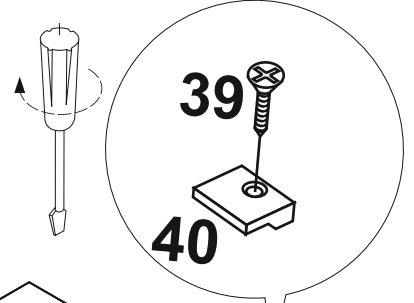

VII

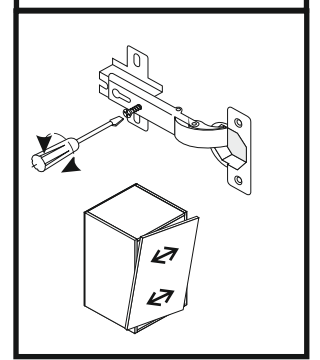
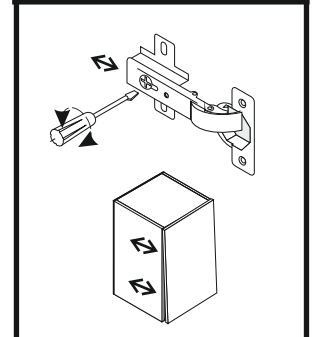
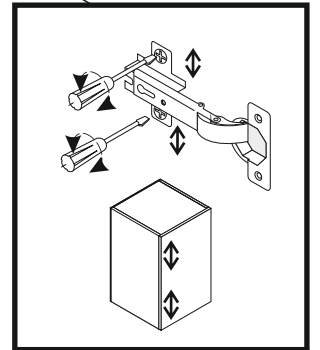
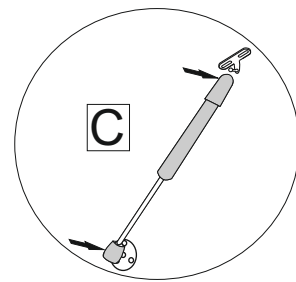
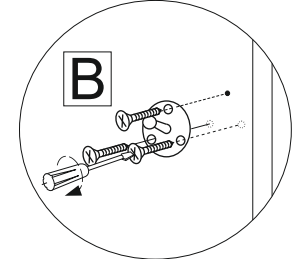
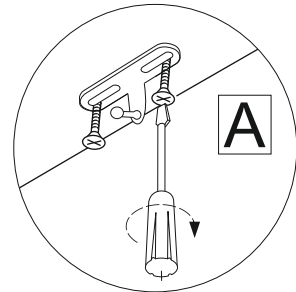
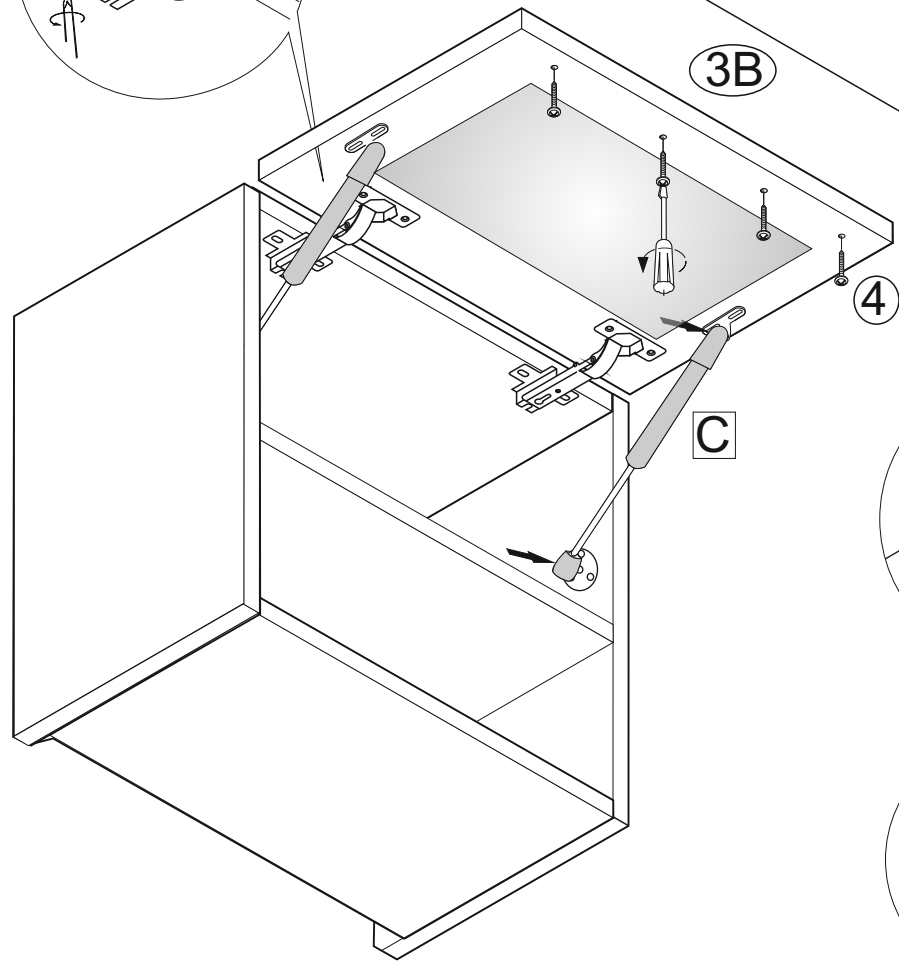
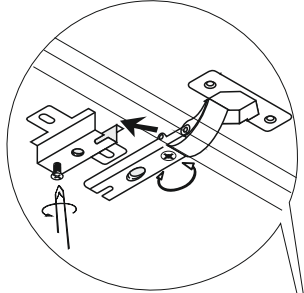

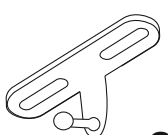
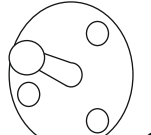
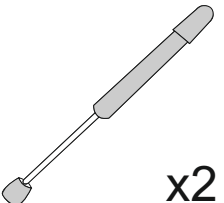
 x2	 x2	 x2
76A	76B	76C

I

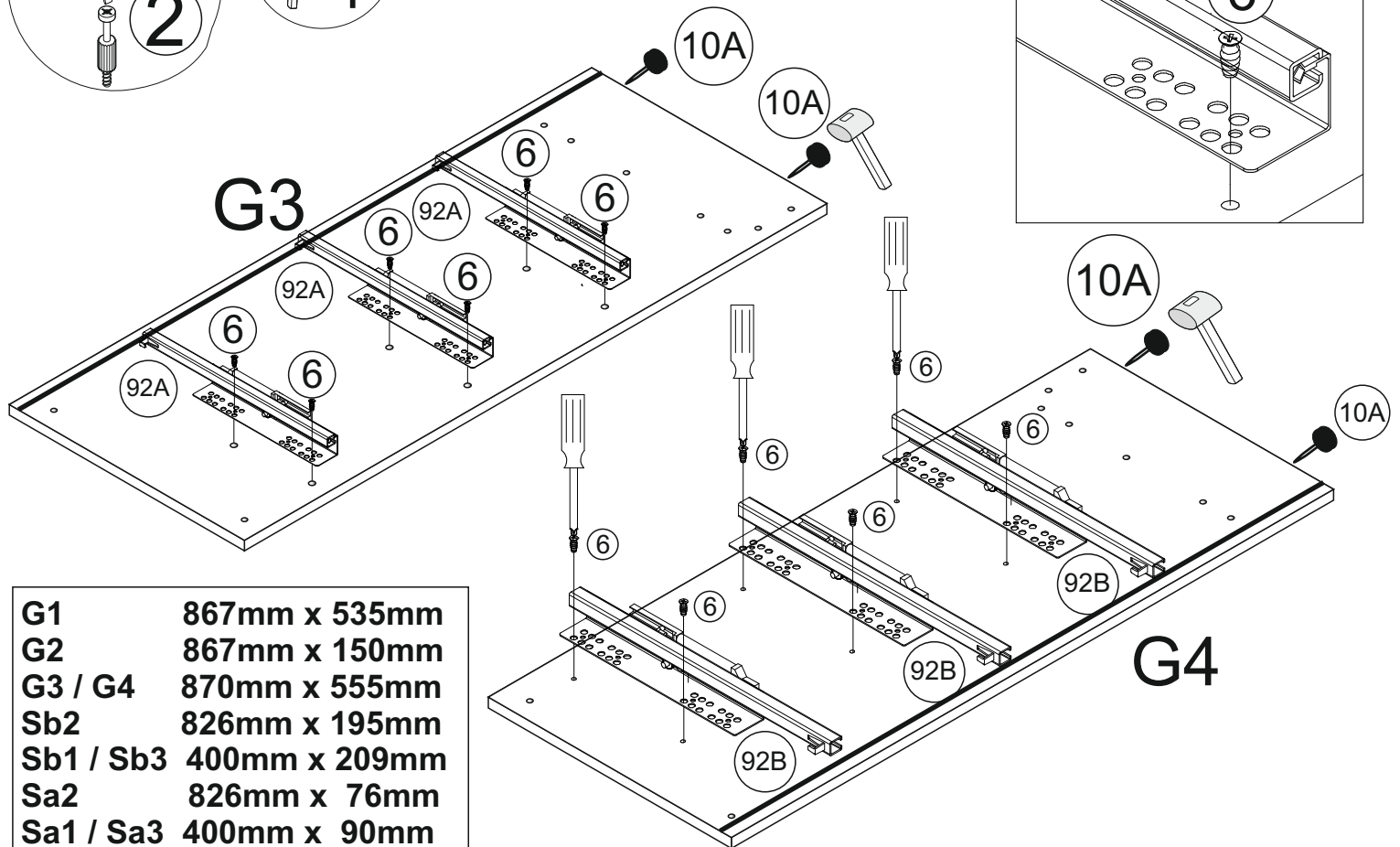
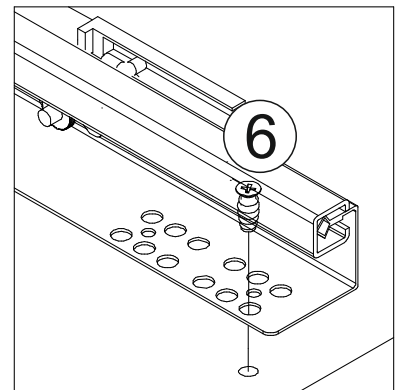
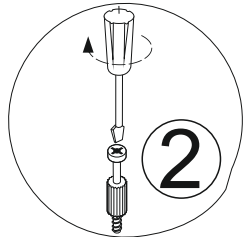
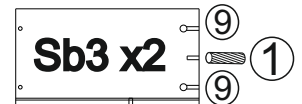
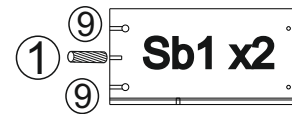
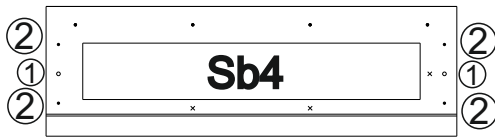
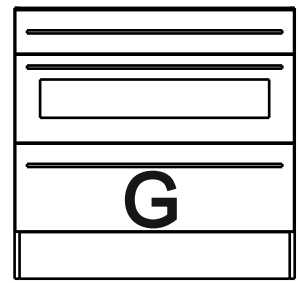
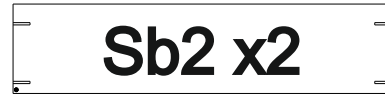
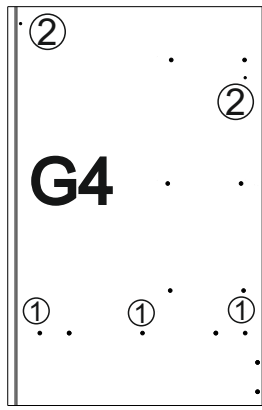
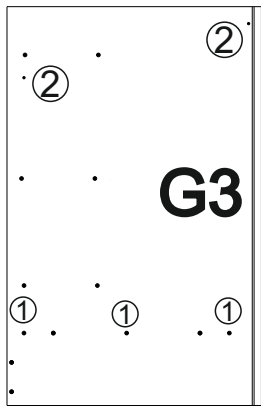

G1	867mm x 535mm
G2	867mm x 150mm
G3 / G4	870mm x 555mm
Sb2	826mm x 195mm
Sb1 / Sb3	400mm x 209mm
Sa2	826mm x 76mm
Sa1 / Sa3	400mm x 90mm
G8	867mm x 74mm

II

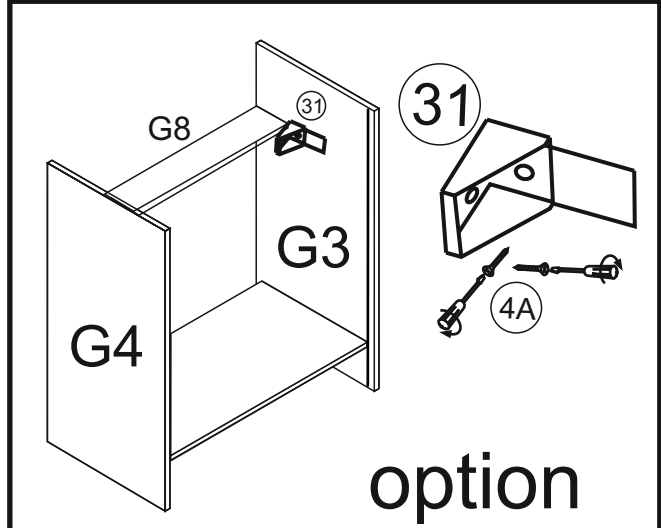
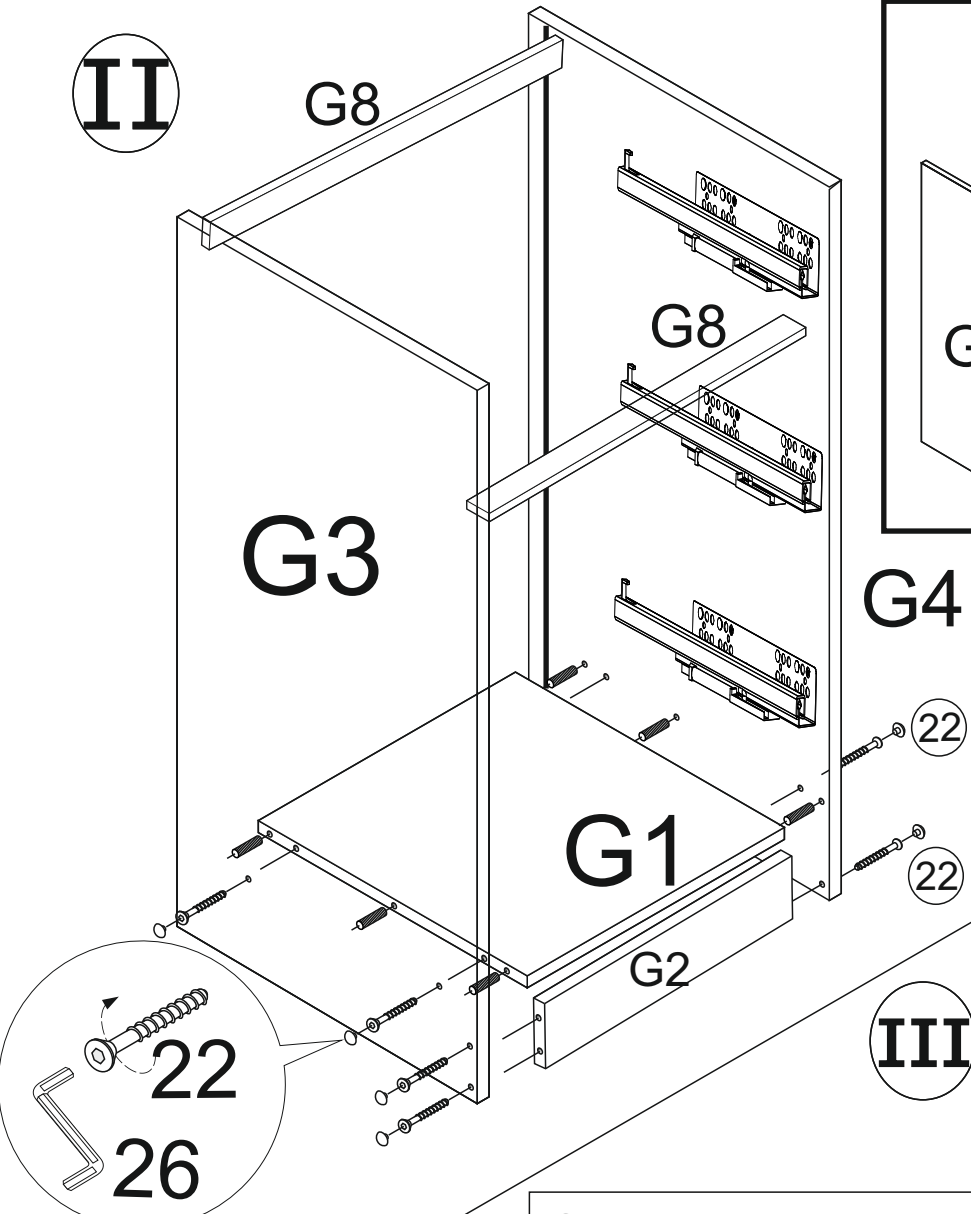

III

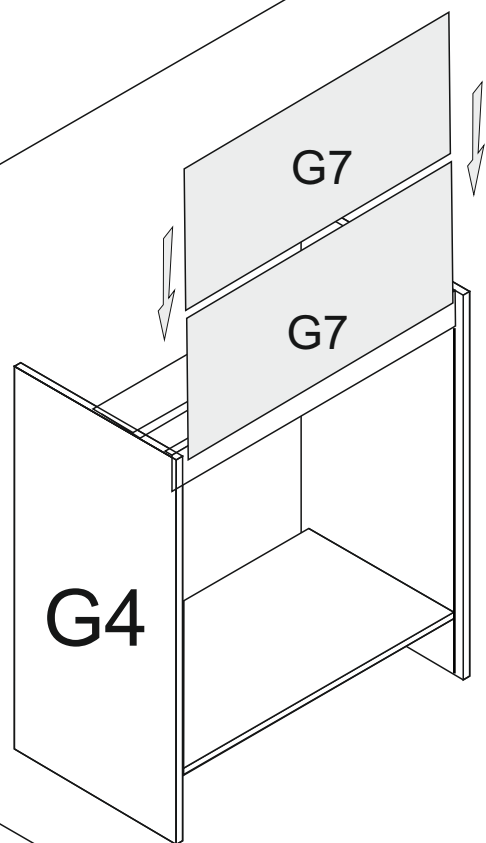

G7 358mm x 877mm

IV

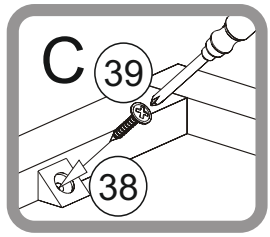
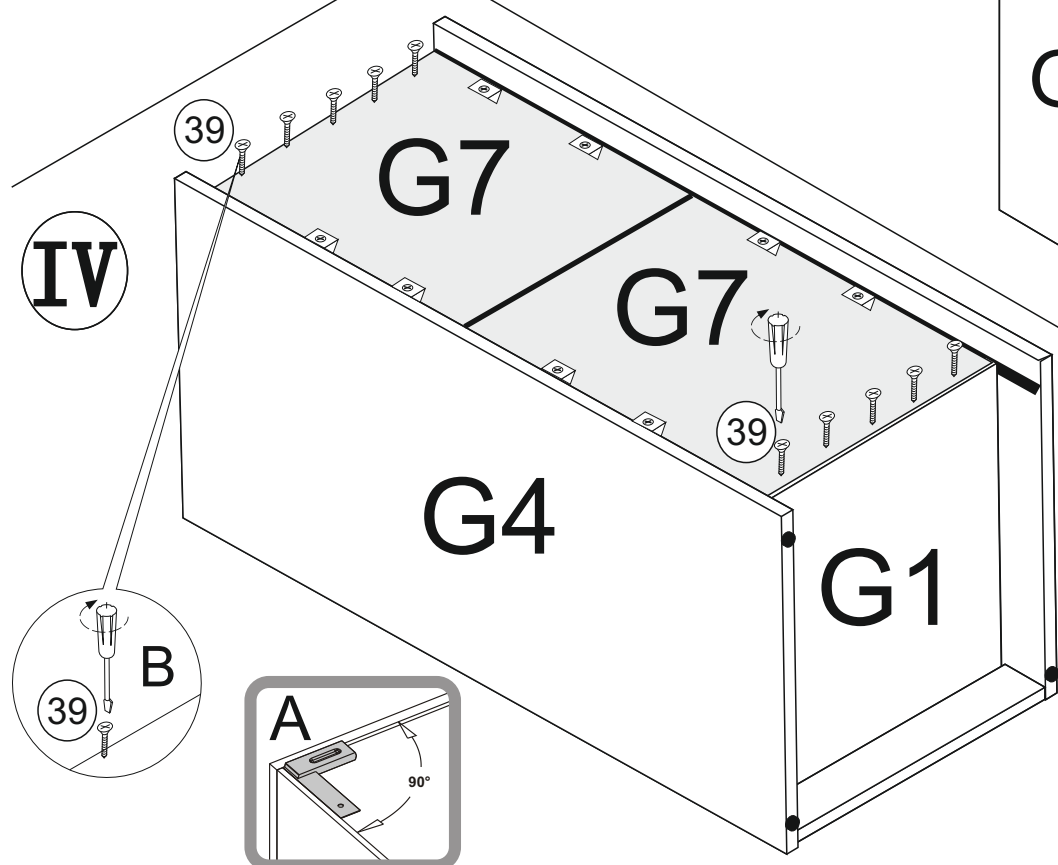

V

Sa1	400mm x 90mm
Sa2	826mm x 76mm
Sa3	400mm x 90mm
Sa4	140mm x 896mm
Sa5	405mm x 836mm

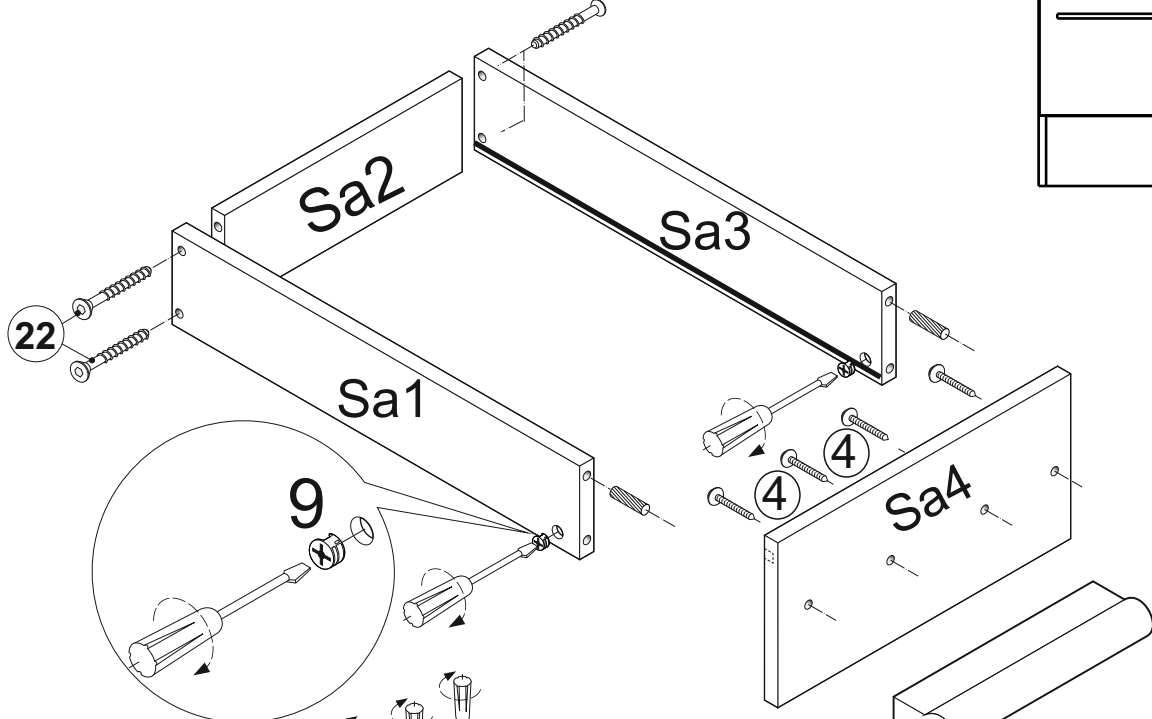
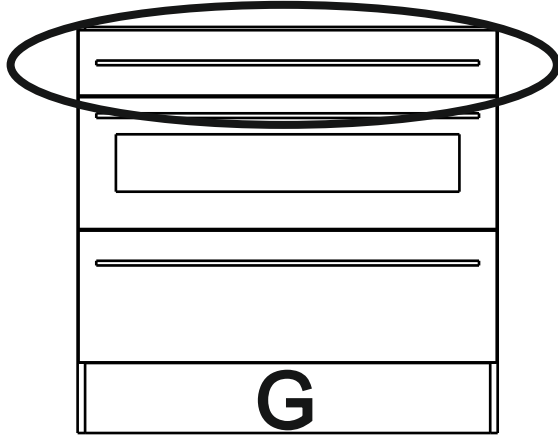

3B

VI

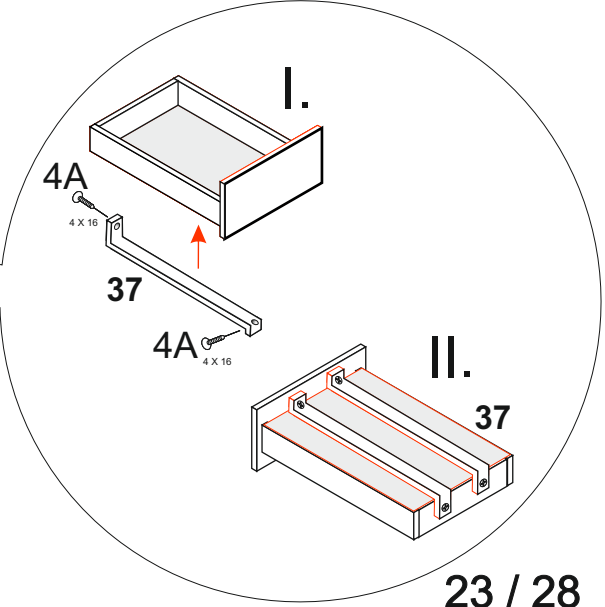
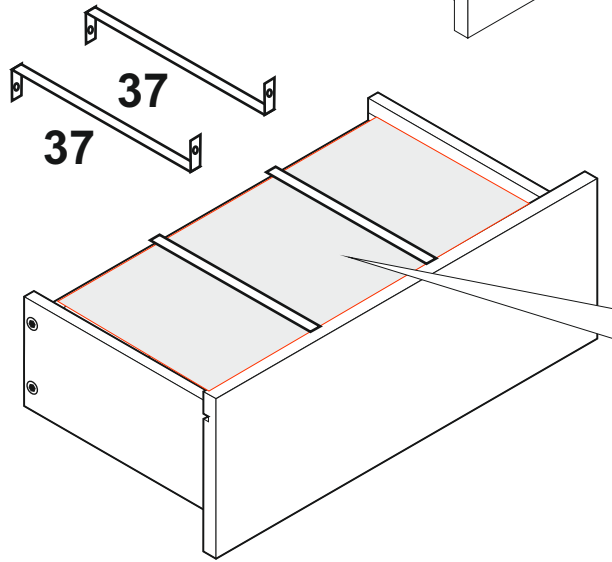
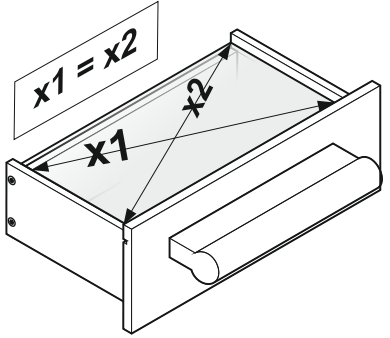
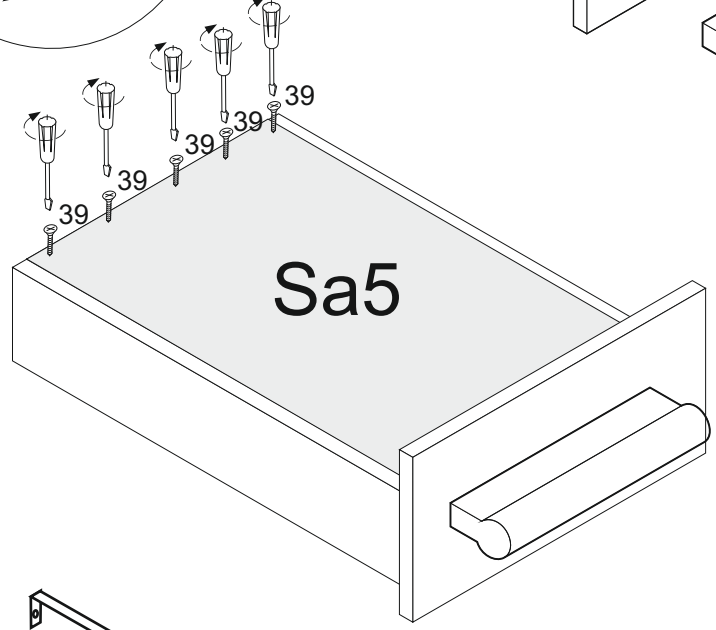

- Sb1 400mm x 209mm
- Sb2 826mm x 195mm
- Sb3 400mm x 209mm
- Sc4 283mm x 896mm
- Sa5 405mm x 836mm

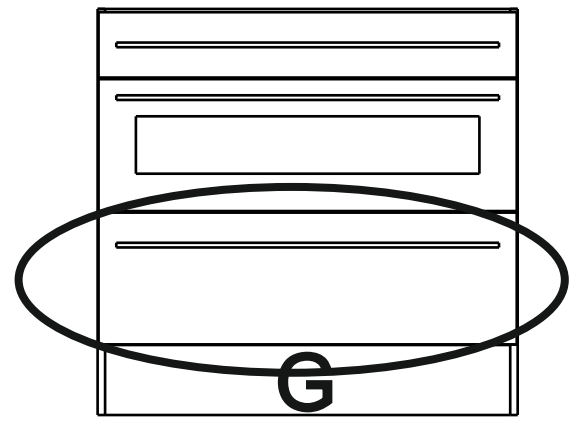

VII

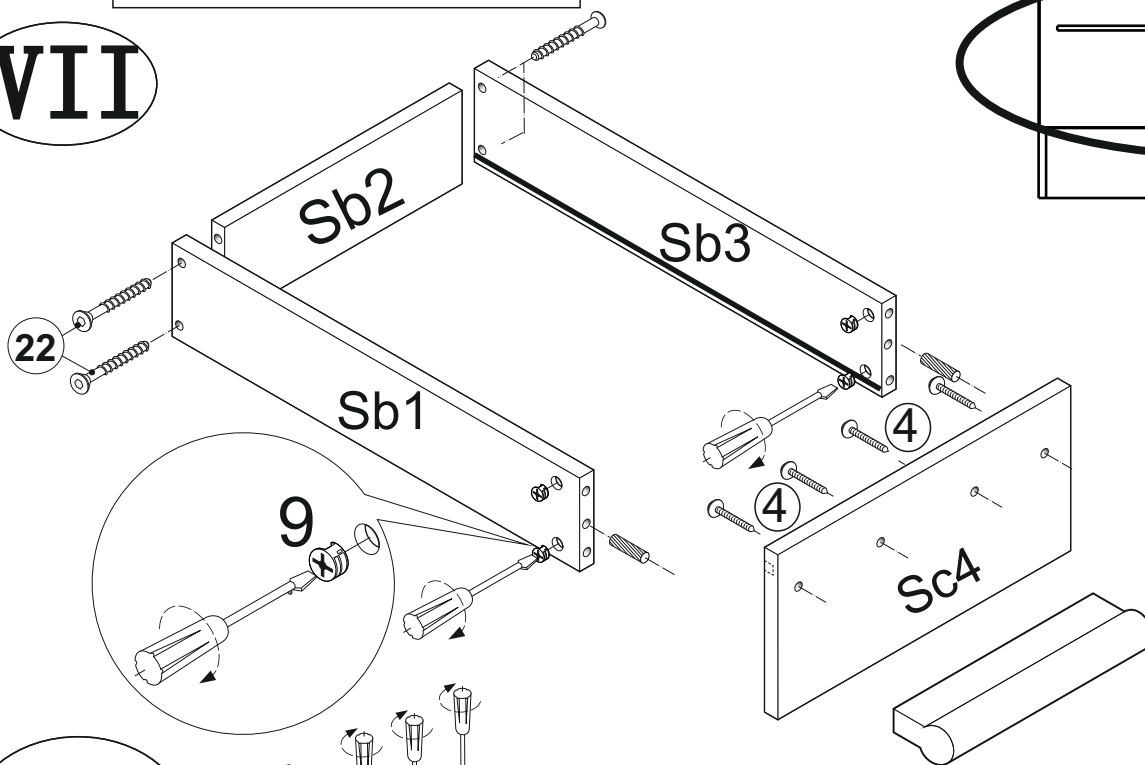

3B

VIII

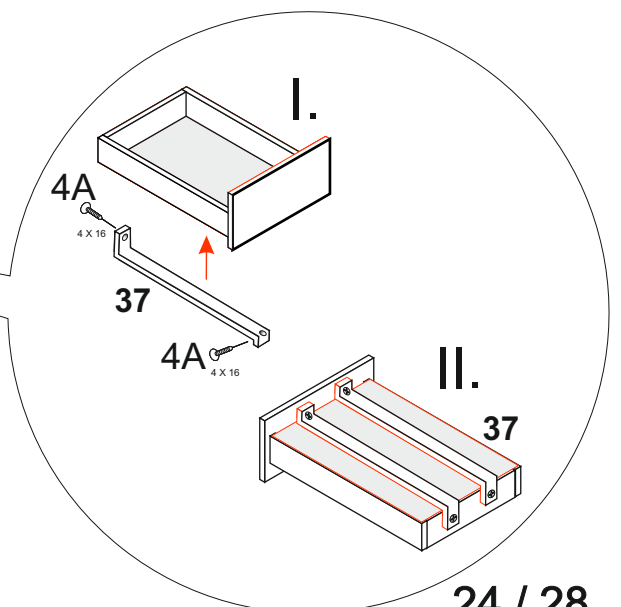
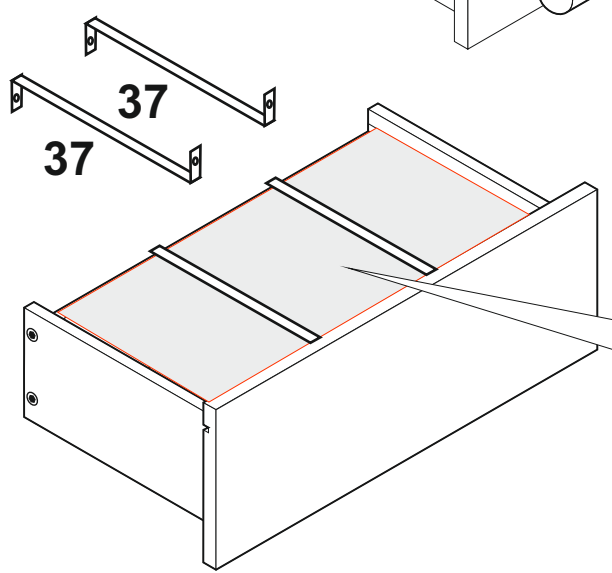
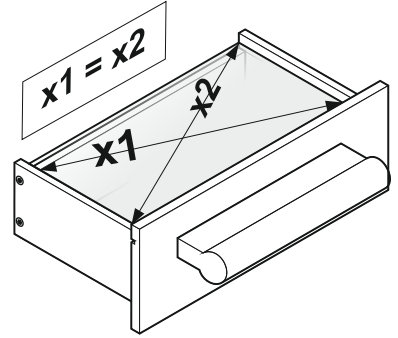
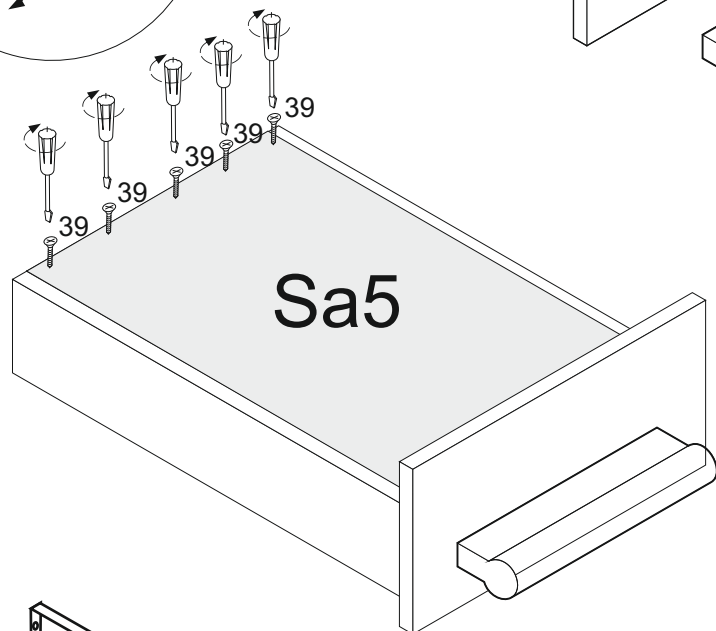

- Sb1 400mm x 209mm
- Sb2 826mm x 195mm
- Sb3 400mm x 209mm
- Sb4 283mm x 896mm
- Sa5 405mm x 836mm
- Sb6 766mm x 153mm

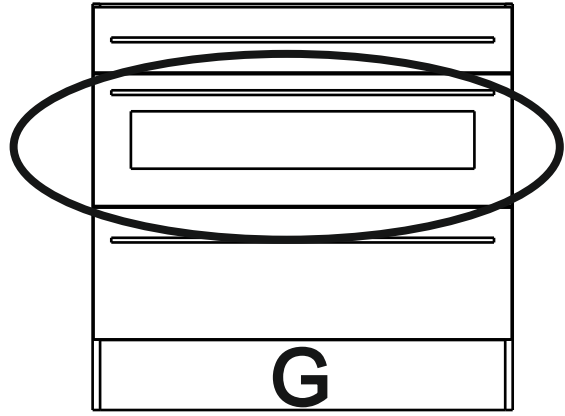

IX

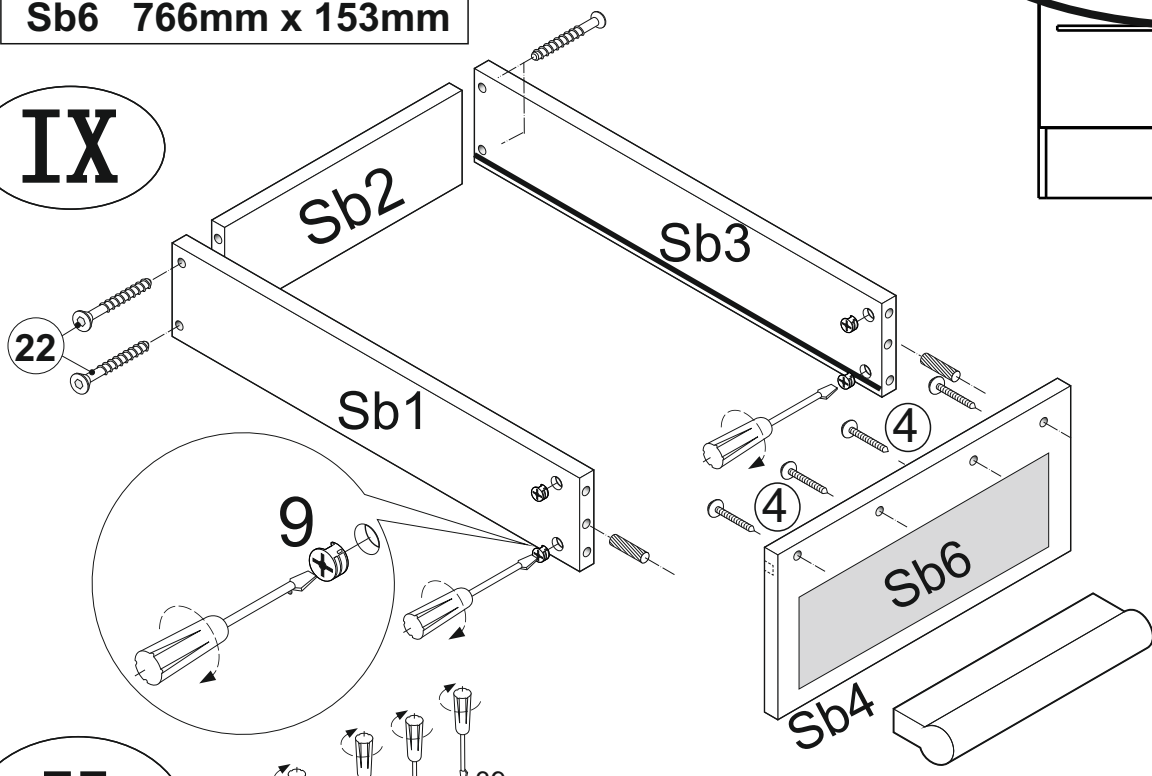

3B

X

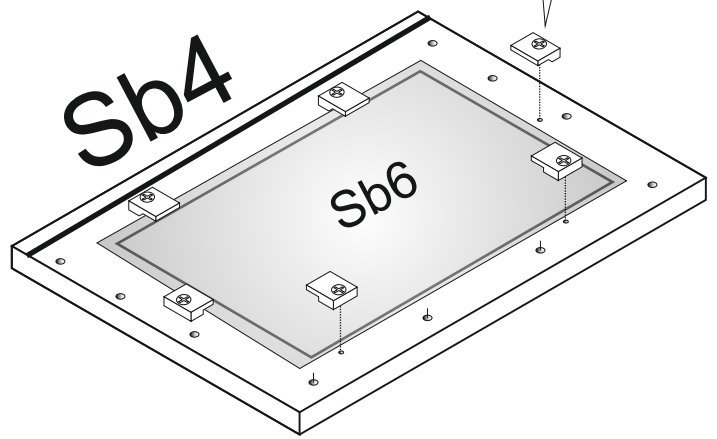
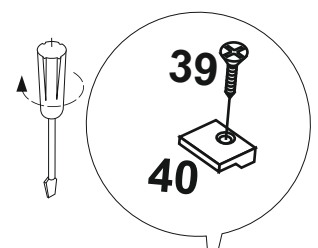
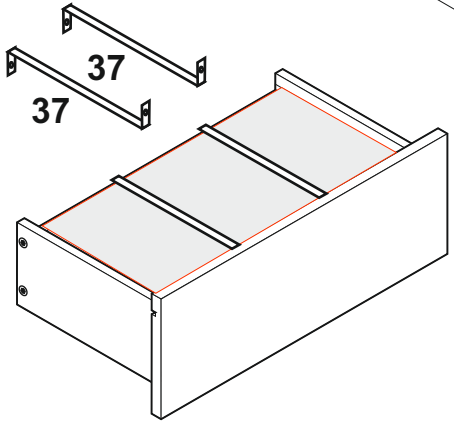
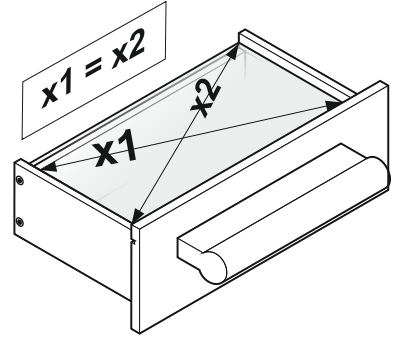
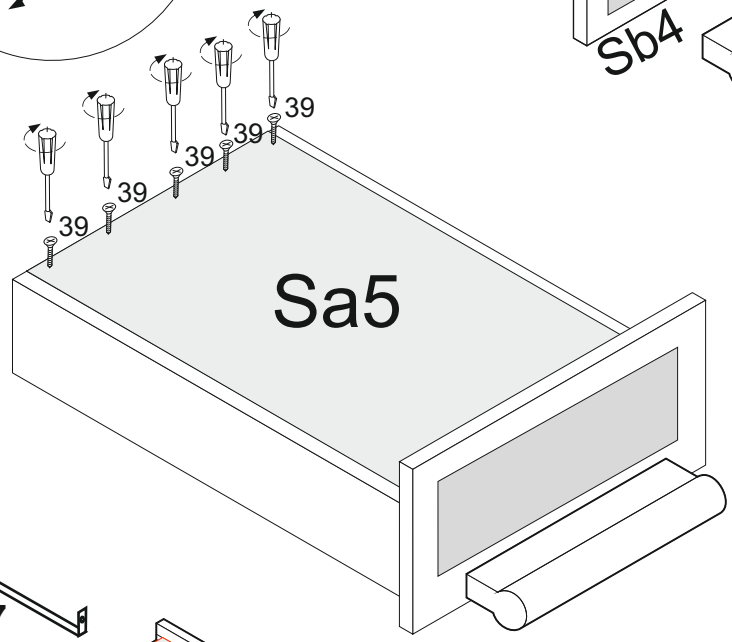

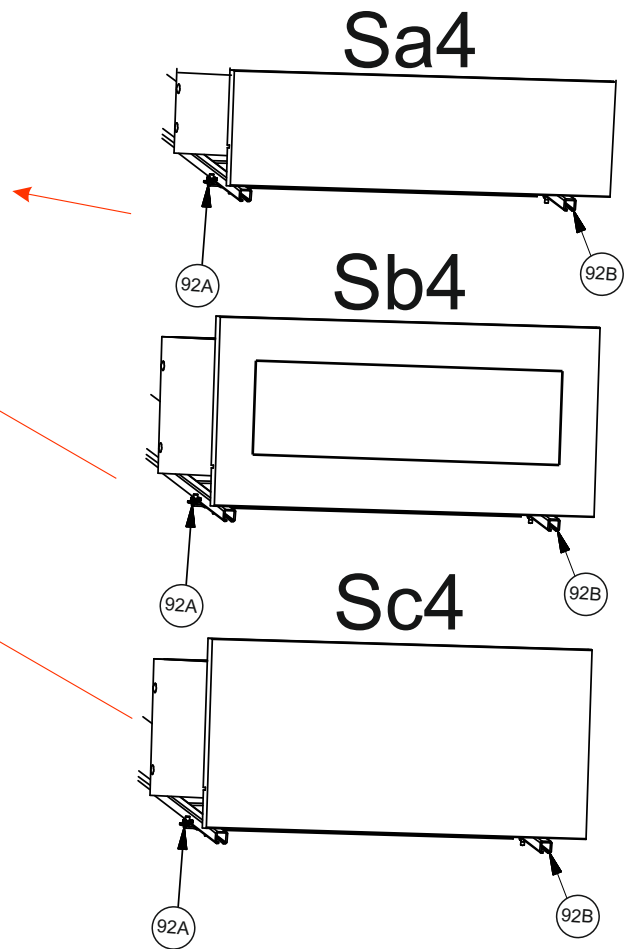
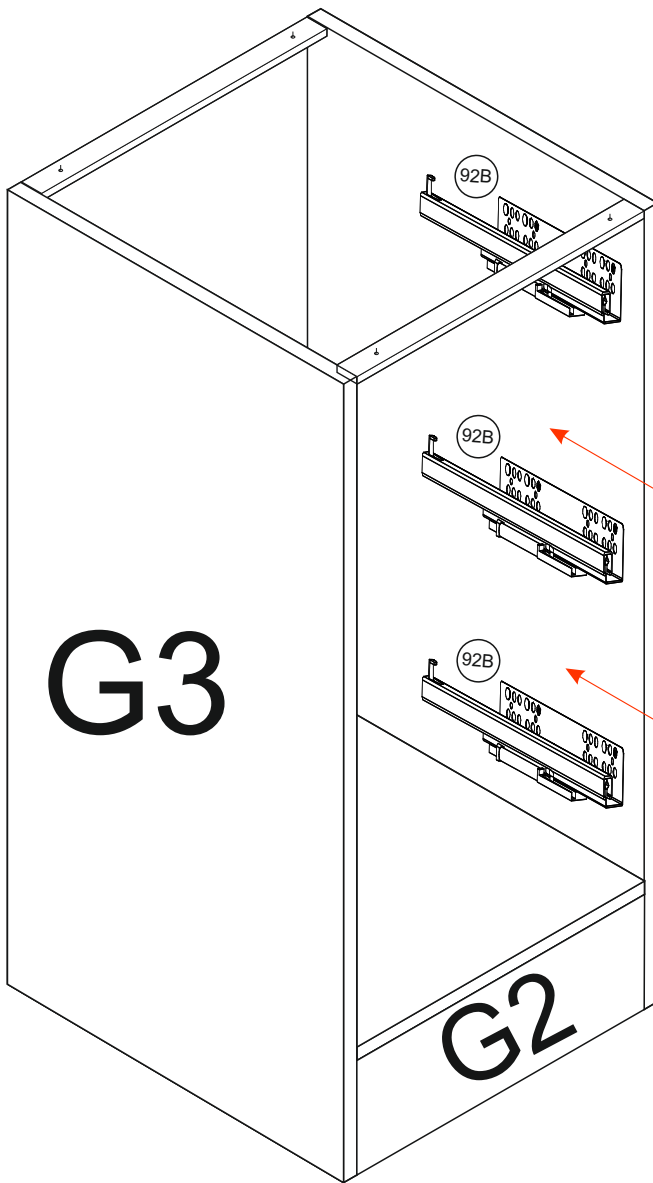
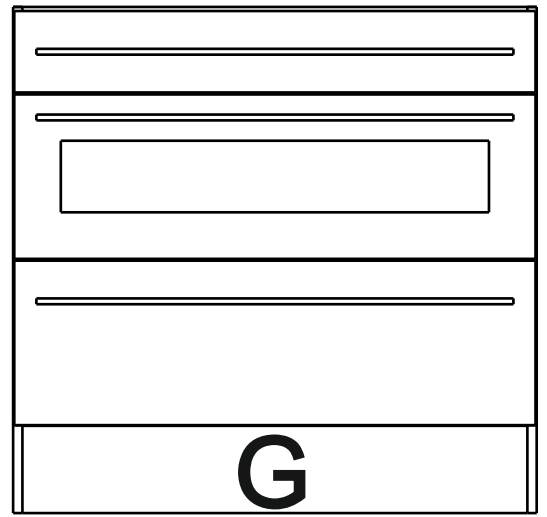
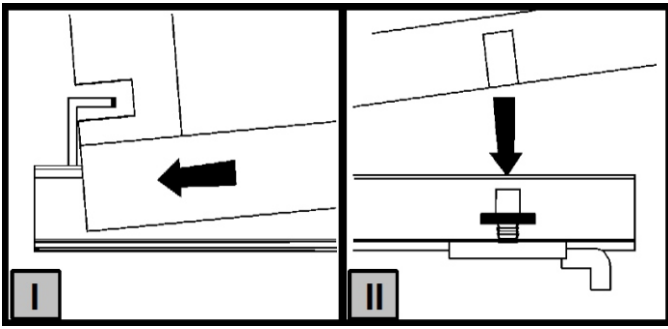

I

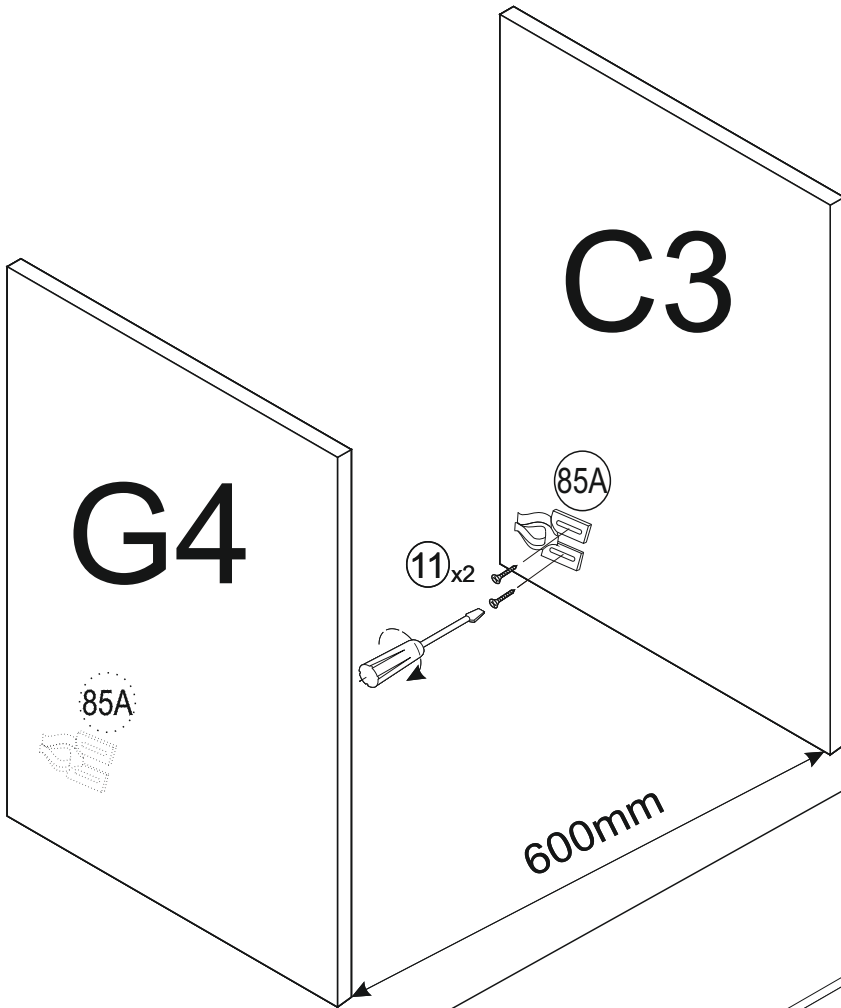
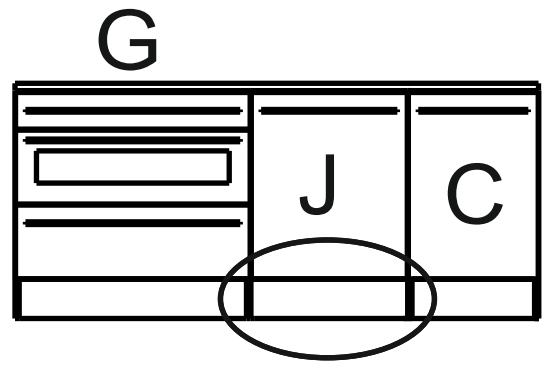



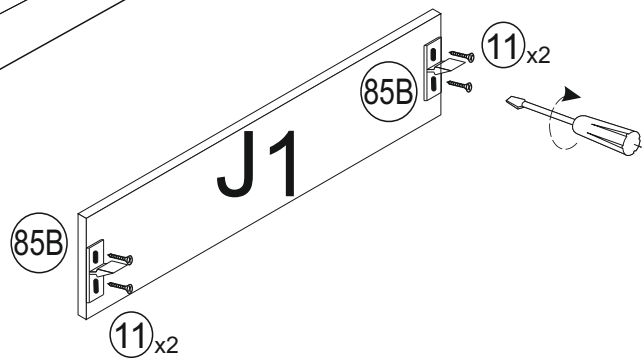

II

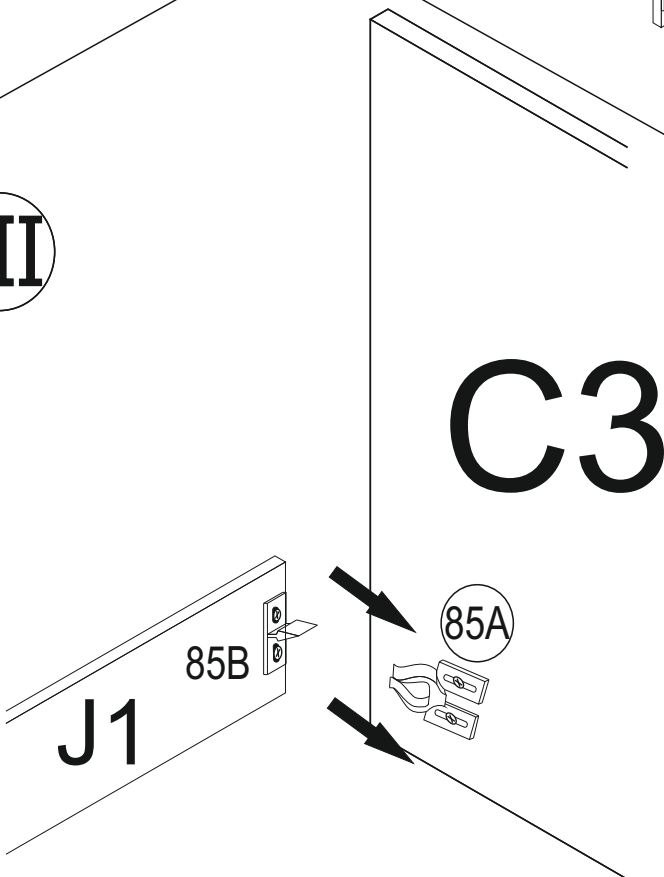

J1 600mm x 150mm

III



85B		x 2
85A		x 2
11		x 8

3.5x13

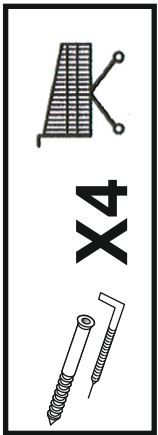
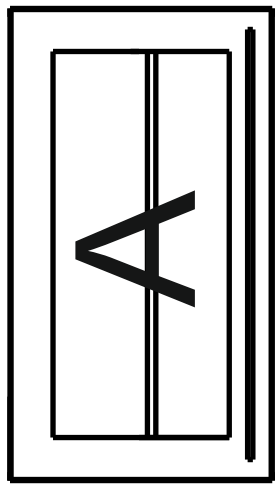

Z2

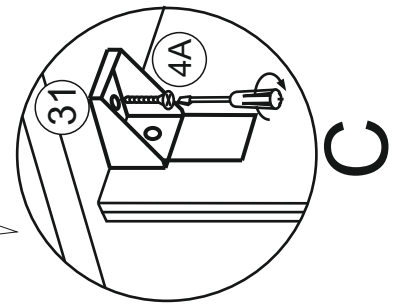
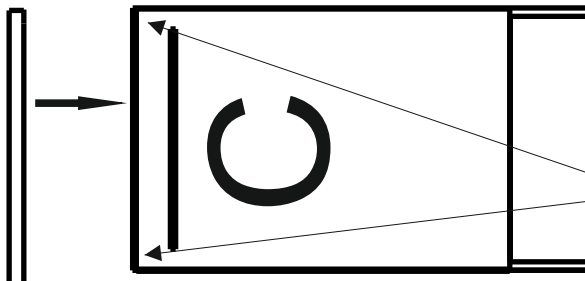

C

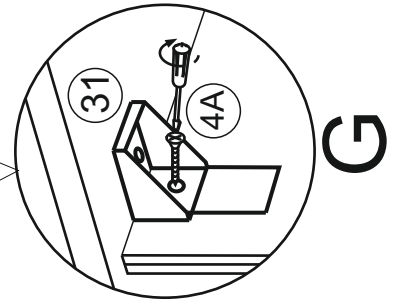
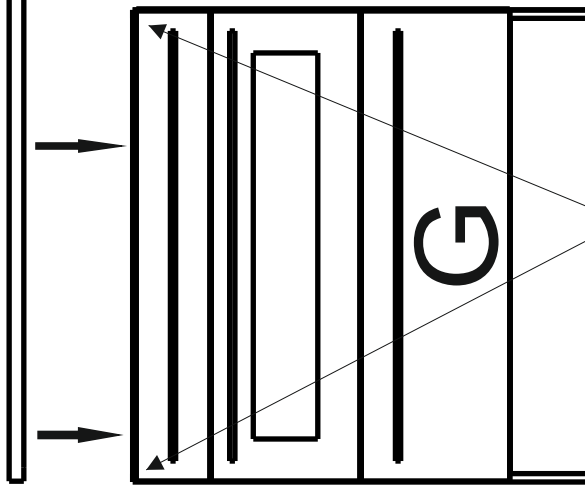

G

Z1

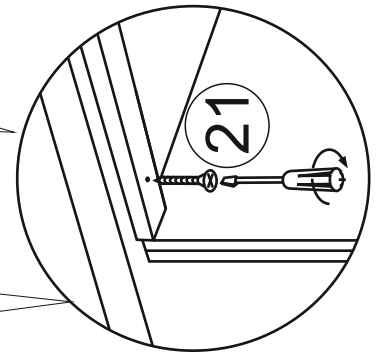
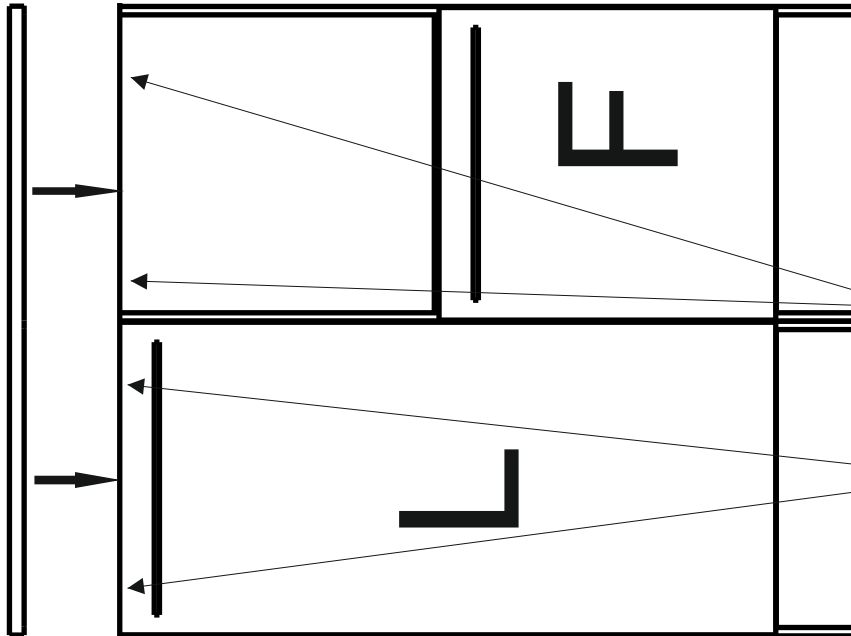

21

