

**D****Wichtige Pflegehinweise**

Bitte beachten Sie die wichtigen Pflegehinweise auf unserer Internetseite



www.held-hilft.de



Pflegehinweise

**PL****Ważne instrukcje dotyczące pielęgnacji**

Zwróć uwagę na ważną instrukcję dotyczącą pielęgnacji na naszej stronie internetowej



www.held-hilft.de



Pflegehinweise

**GB****Important care instructions**

Please note the important care instructions on our website



www.held-hilft.de



Pflegehinweise

**SK****Dôležité pokyny na starostlivosť**

Dbajte na dôležité pokyny týkajúce sa starostlivosti na našich webových stránkach



www.held-hilft.de



Pflegehinweise

**FR****Instructions d'entretien importantes**

S'il vous plaît noter les instructions de soins importants sur notre site Web



www.held-hilft.de



Pflegehinweise

**HU****Fontos kezelési utasítások**

Kérjük, vegye figyelembe a honlapunkon található fontos kezelési útmutatót



www.held-hilft.de



Pflegehinweise

**IT****Importanti istruzioni per la cura**

Si prega di notare le importanti istruzioni per la cura sul nostro sito web



www.held-hilft.de



Pflegehinweise

**RO****Instrucțiunile importante de îngrijire**

Rețineți instrucțiunile importante de îngrijire de pe site-ul nostru



www.held-hilft.de



Pflegehinweise

**NL****Belangrijke zorginstructies**

Let op de belangrijke zorginstructies op onze website



www.held-hilft.de



Pflegehinweise

**TR****Önemli bakım talimatları**

Lütfen web sitemizdeki önemli bakım talimatlarını dikkate alınız



www.held-hilft.de



Pflegehinweise

**CZ****Důležité pokyny pro péči**

Vezměte prosím na vědomí důležité pokyny pro péči na našich webových stránkách



www.held-hilft.de



Pflegehinweise

**RU****Важные инструкции по уходу**

Обратите внимание на важные инструкции по уходу на нашем веб-сайте



www.held-hilft.de



Pflegehinweise



88844.313 19-10-2016

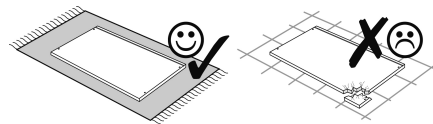
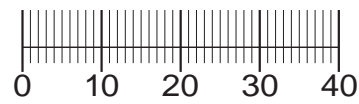
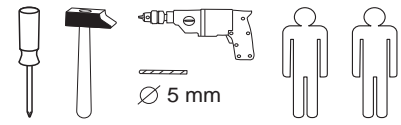

1 4 x 2802	2 4 x 2801	3 8 x 2815	4 28 x 2804	5 12 x 2861
7 1 x 2863	8 4 x 1122	9 8 x 2816	10 4 x 2865	11 4 x 1121
13 2 x 2840	14 2 x 2842	15 1 x 2881	16 1 x 2880	17 2 x 2830
19 2 x 5285.400	20 2 x 5284.400	Silikon 25ml 21 1 x 1970		

Das beigegefügte Wandbefestigungsmaterial (Dübel und Schrauben) eignet sich nur für festes Mauerwerk (z.B.: Beton- oder Ziegelwände). Für andere Wandaufbauten sind eventuell Spezialdübel und andere Schrauben notwendig. Ziehen Sie gegebenenfalls eine Fachkraft zu Rate.

Приложенный материал для крепления к стене (дюбели и винты) пригоден только для жестких кладок (например, бетонные или кирпичные стены). Для других настенных конструкций необходимы смотря по обстоятельствам специальные дюбели и другие винты. При необходимости проконсультируйтесь у специалиста.

Zalążony materiał do mocowania do ściany (kolki rozprężne i wkręty) nadaje się tylko do ścian murowanych (np. z betonu lub cegiel). Do ścian wykonanych w innych technologiach konieczne być mogą specjalne kolki rozprężne i inne wkręty. W razie potrzeby skorzystaj z fachowej pomocy.

The accompanying wall mounting hardware (anchors and screws) is suitable only for solid masonry (eg concrete or brick walls). For other wall structures are possibly special anchor bolts and other necessary. Tighten if necessary, an expert.

De begeleidende wandmontage hardware (pluggen en schroeven) is alleen geschikt voor massief metselwerk (bijvoorbeeld beton of bakstenen muren). Voor andere muur structuren zijn eventueel bijzondere ankerbouten en andere noodzakelijke. Draai indien nodig, een deskundige.

Le mur d'accompagnement matériel de montage (chevilles et les vis) ne convient que pour la maçonnerie solide (par exemple en béton ou des murs de briques). Pour les structures de mur d'autres sont peut-être spéciale boulons d'ancrage et d'autres nécessaires. Serrer le cas échéant, un expert.

Il muro di accompagnamento hardware di montaggio (tasselli e viti) è adatto solo per muratura piena (ad esempio calcestruzzo o muratura). Per le altre strutture murarie sono forse speciali bulloni di ancoraggio e necessari di altri. Serrare se necessario, un esperto.

Ekteki duvara sabit montaj malzemeleri (dübel ve vidalar), sadece sağlam duvarlar için (örnek: beton veya tuğla) elverişlidir. Başka duvarlar için özel dübeller ve farklı vidalar gerekebilir. Gerektiğinde bir bilene danışınız.

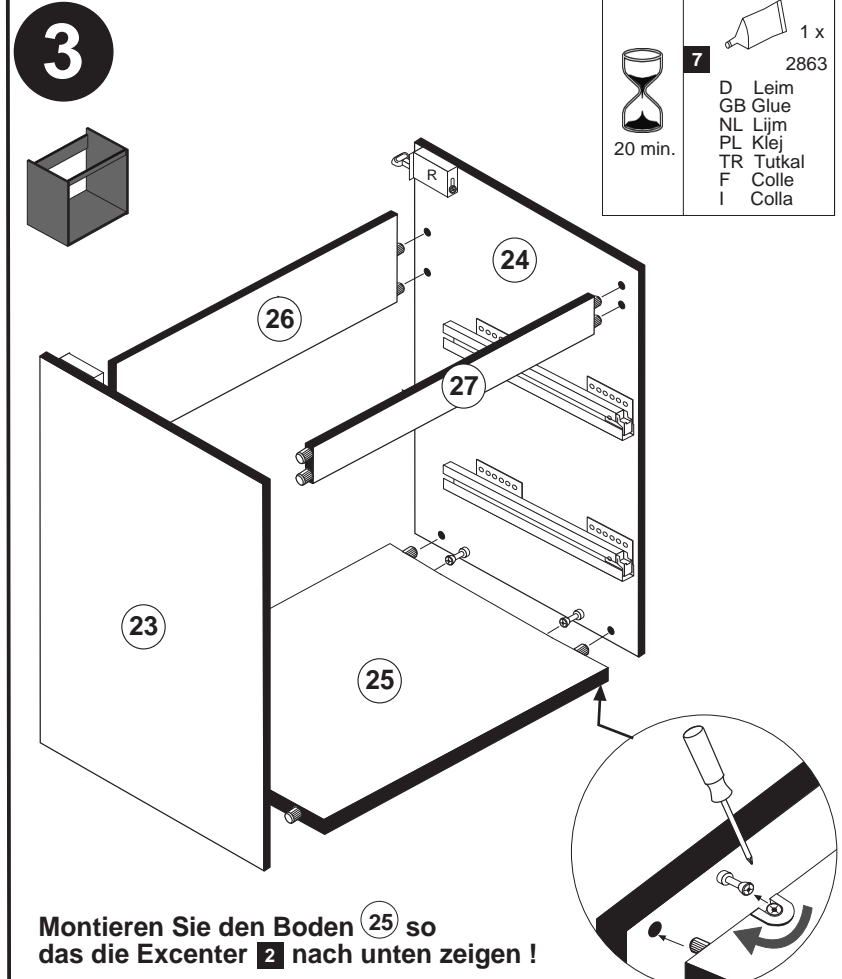
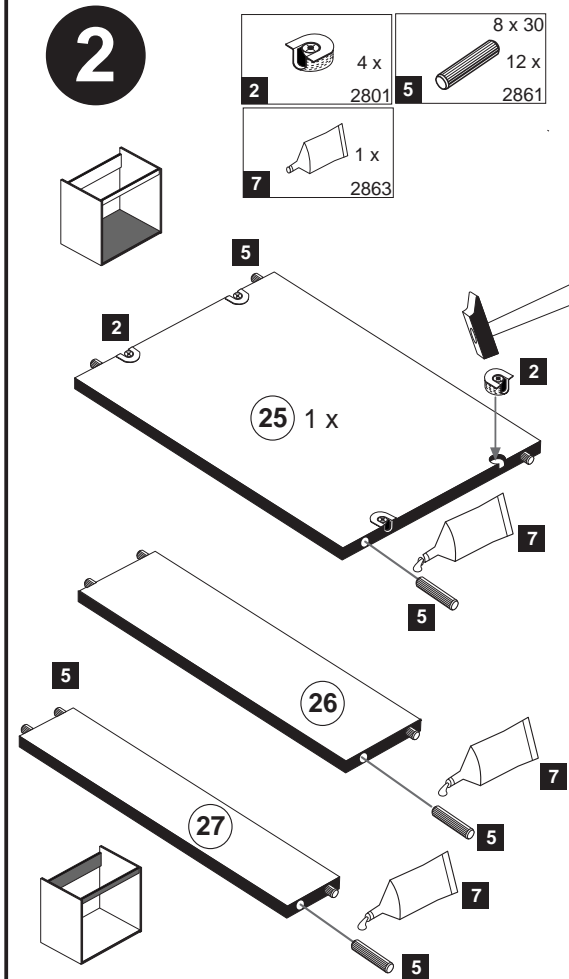
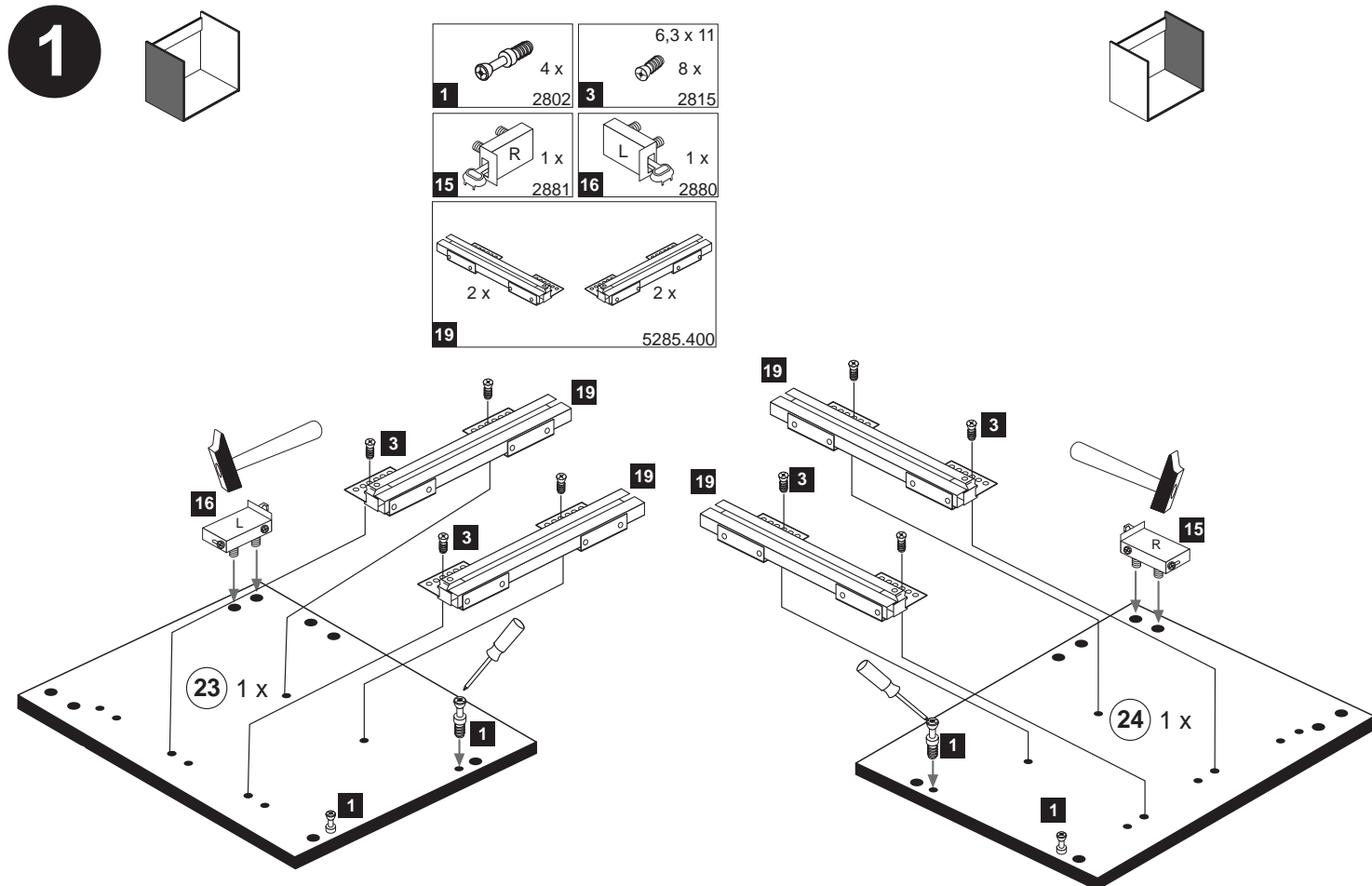
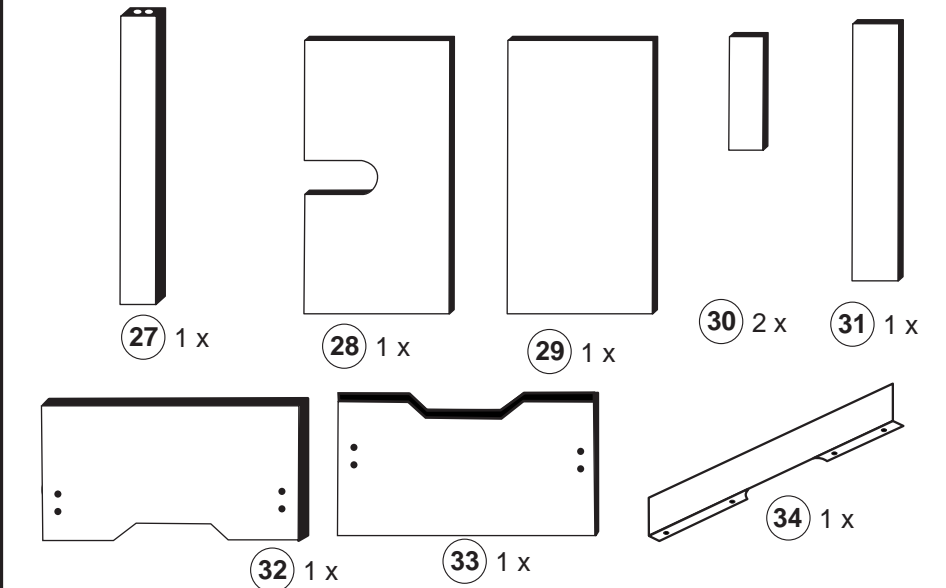
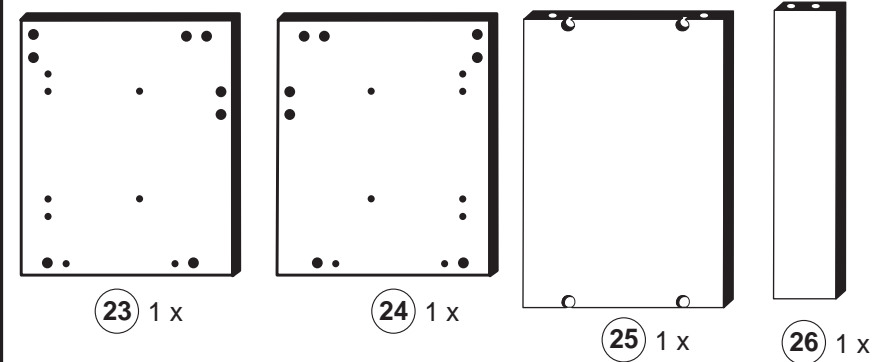

	20 min.		1 x 2863
D	Leim		
GB	Glue		
NL	Lijm		
PL	Klej		
TR	Tutkal		
F	Colle		
I	Colla		

Montieren Sie den Boden (25) so das die Excenter (2) nach unten zeigen !

4

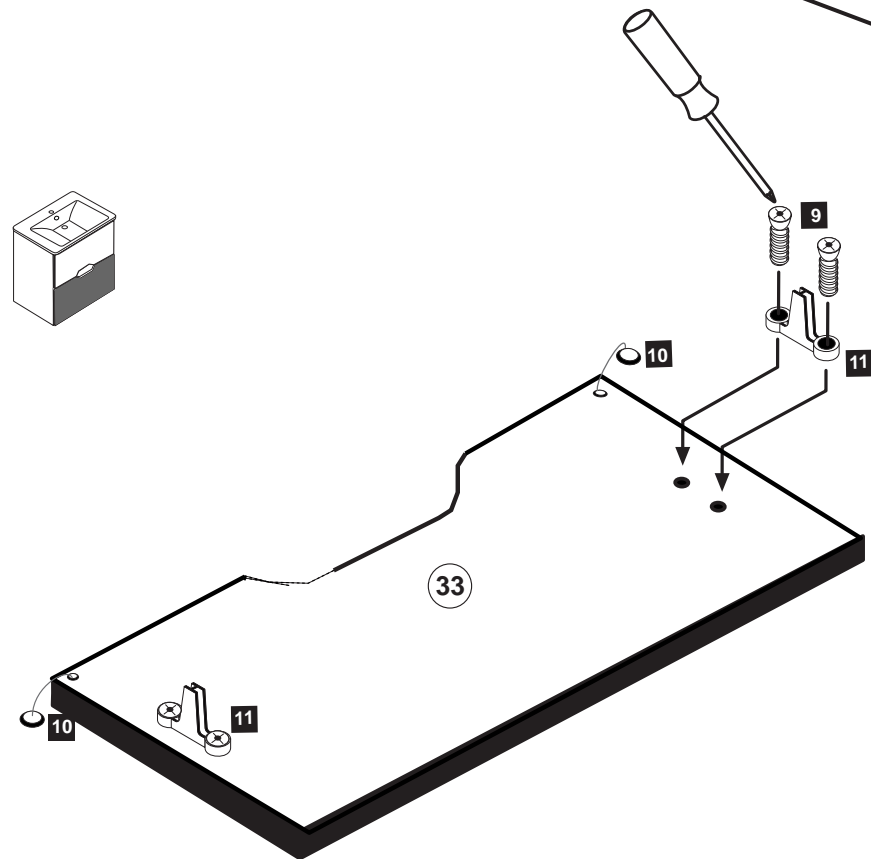
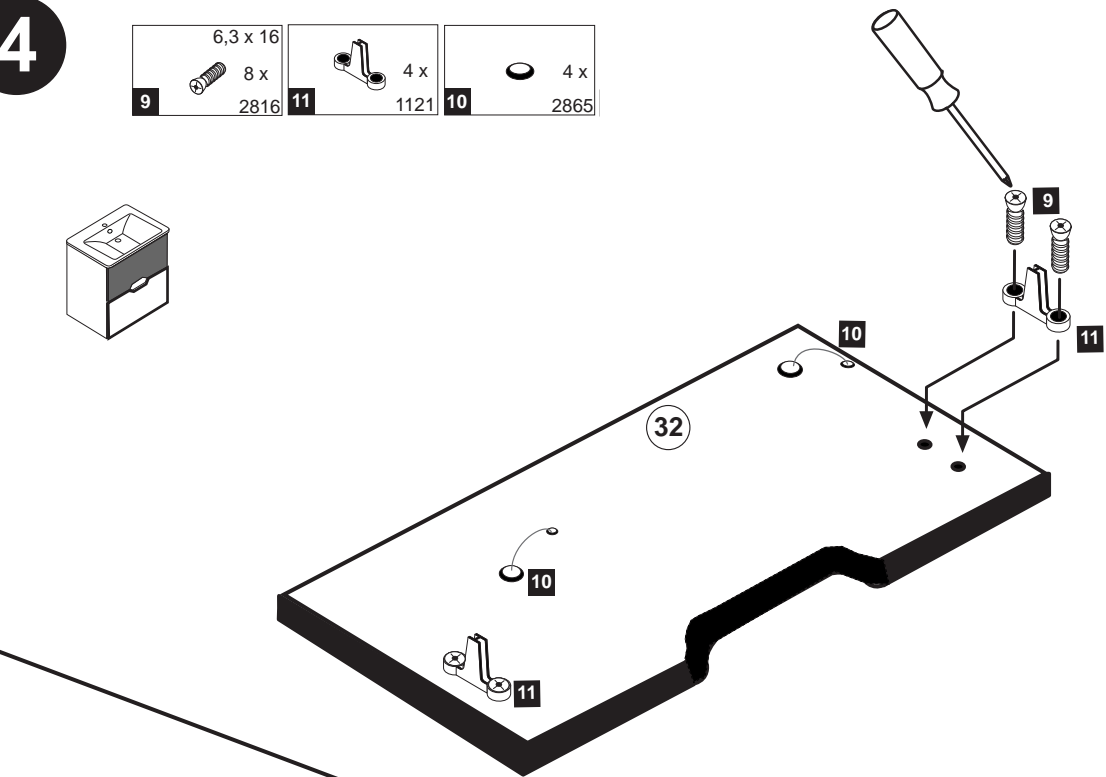
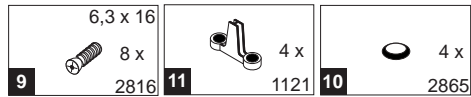

5

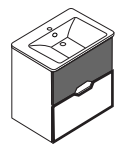

Wichtig!
Montieren Sie den Boden
an der Vorderkante bündig
mit der Zarge 20!

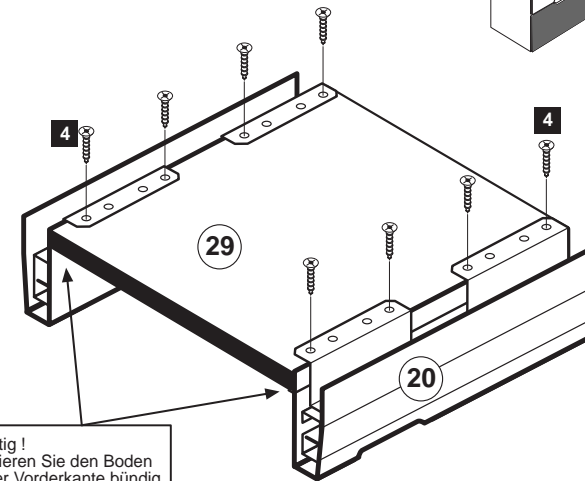
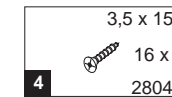
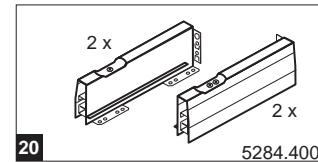
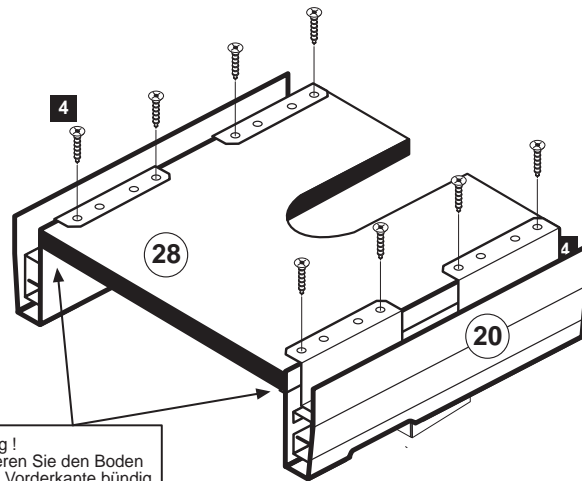

Wichtig!
Montieren Sie den Boden
an der Vorderkante bündig
mit der Zarge 20!

6

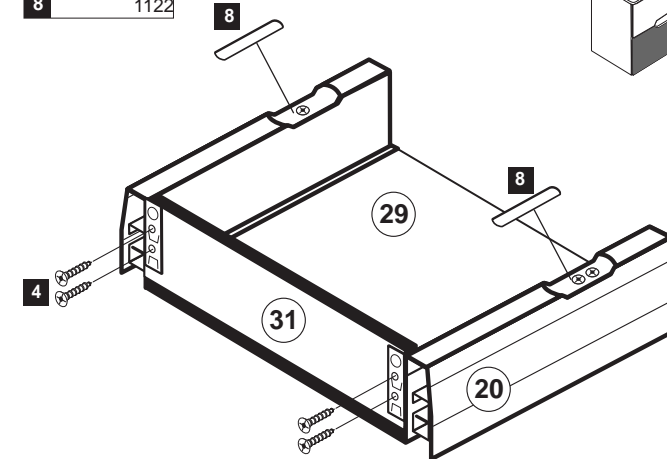
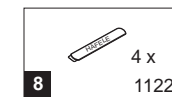
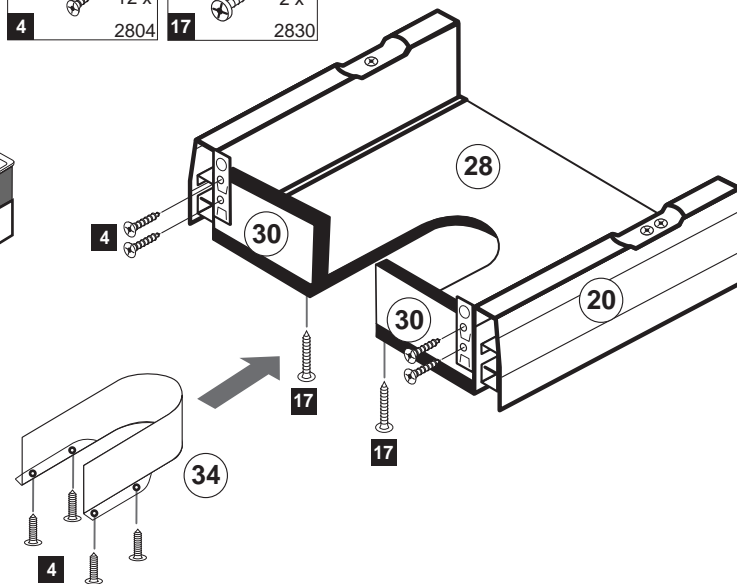
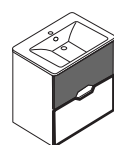
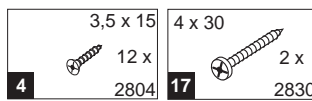

7

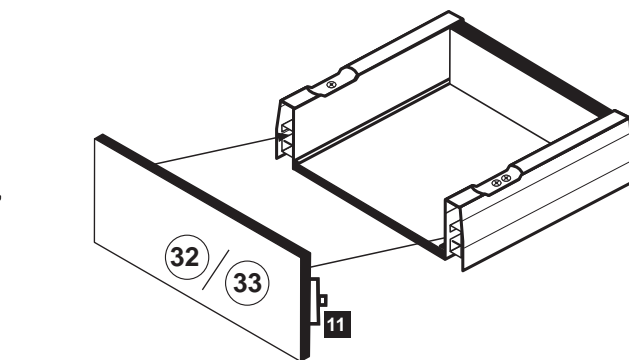
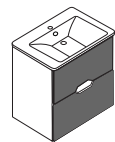

Führen Sie die Schubkastenblende (32)/(33) mit dem Beschlag 11 wie abgebildet in die Zargen 20 ein. Der Beschlag 11 rastet ein!

Wichtig!
Montieren Sie folgende Elemente zusammen:

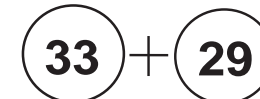
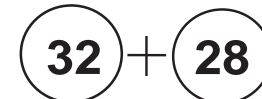

Hinweis!
Wie Sie den Schubkasten einhängen müssen entnehmen Sie bitte dem beigefügten Montagezettel der Firma HÄFELE.
Zusätzlich finden Sie auf dem Montagezettel folgende Abbildungen und Montagehilfen:
- Montage der Abdeckkappe 8
- Einstellen der Schubkastenblende
- Aushängen des Schubkastens
- Abnehmen der Schubkastenblende

11

	5,8 x 55	8 x 30
	2 x	2 x
13	2840	14
		2842

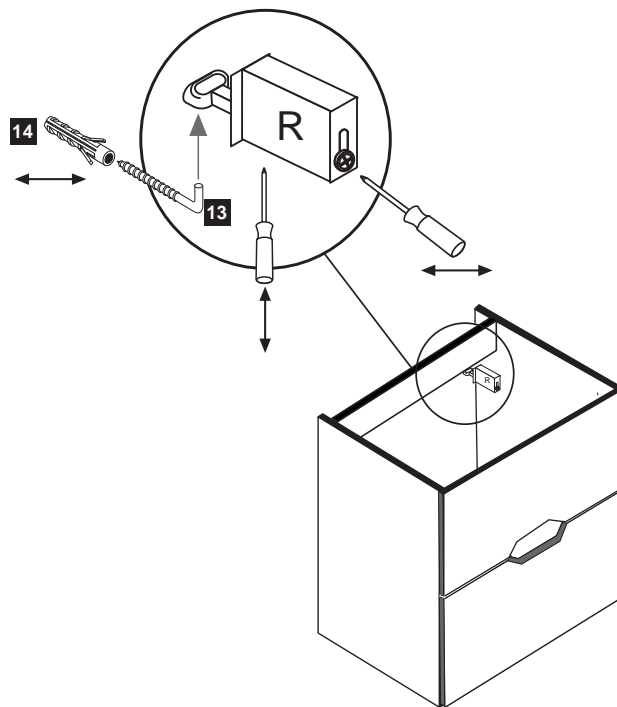
**12**

Silikon 25ml	
	1 x
21	1970

Waschbeckenmontage

1. Silikon auf Stirnkanten der Seiten auftragen
2. Waschbecken auflegen
3. Fuge zwischen Waschbecken und Wand mit Silikon abdichten

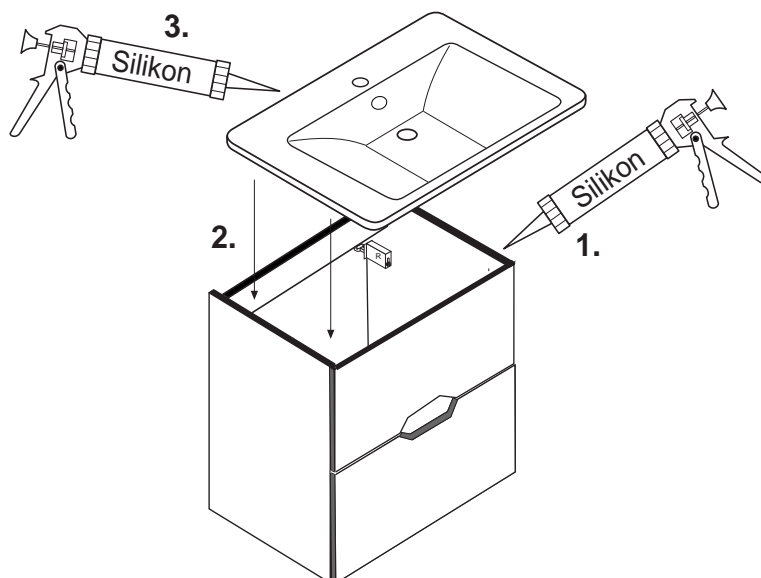

4

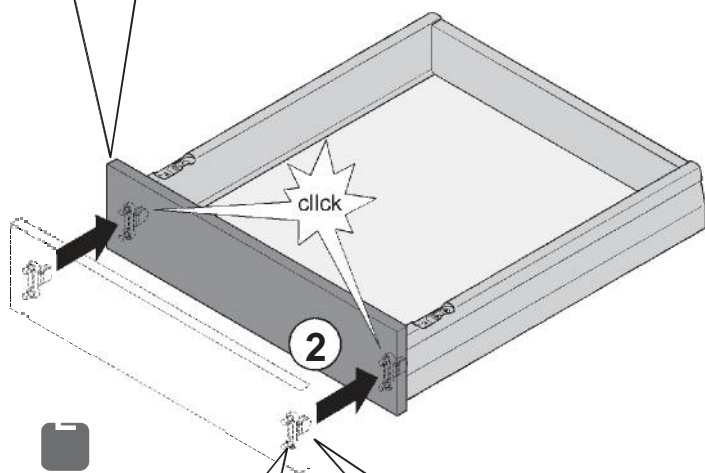
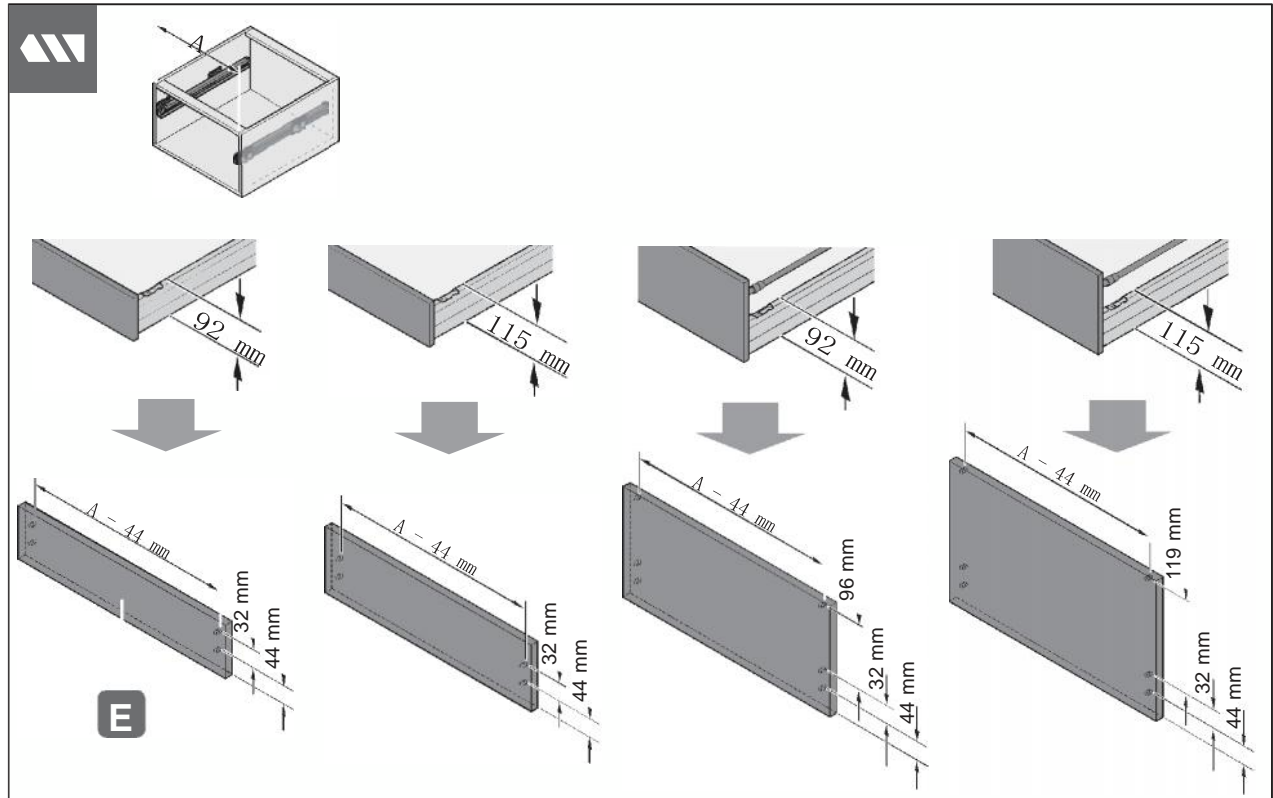

Variante
Version
Versión
Versione

A

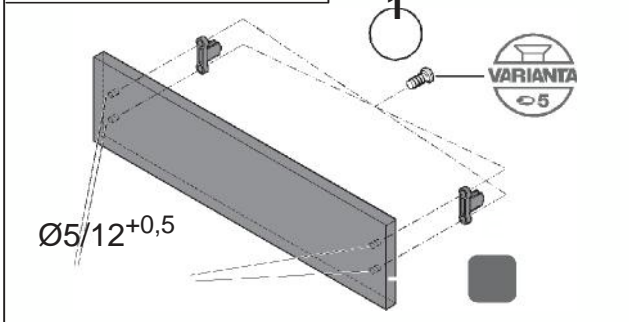

Variante
Version
Versión
Versione

B

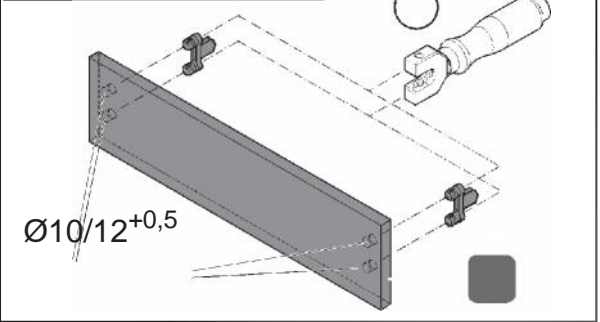

Maße in mm – Dimensions in mm – Medidas en mm – Misure in mm

HDE 10.11.09



5

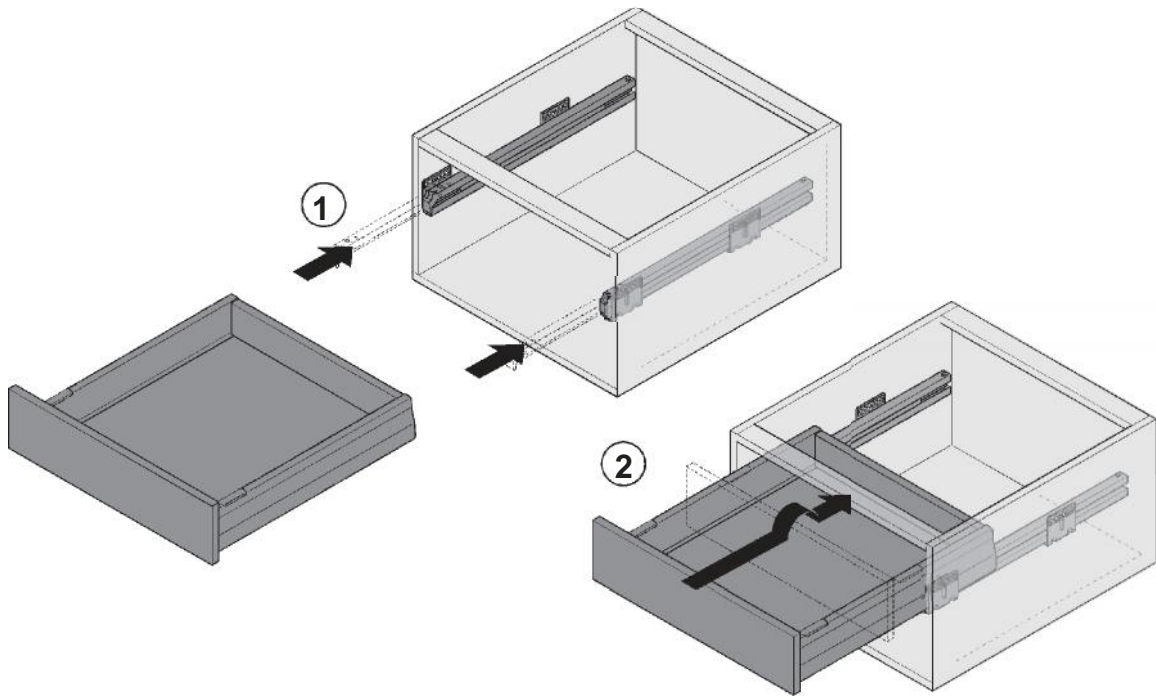

Einstellung

En
Fr
Es
It

HDE 10.11.09 Maße in mm – Dimensions in mm – Mesures en mm – Medidas en mm – Misure in mm

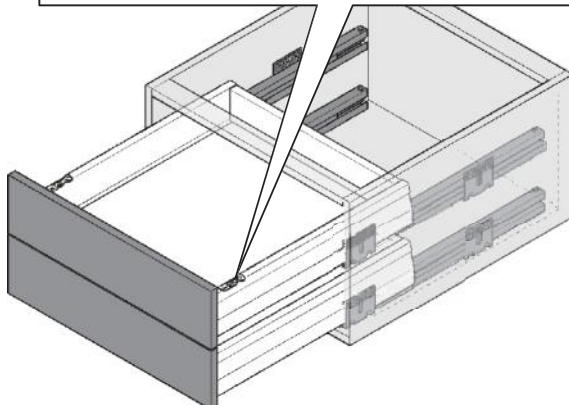
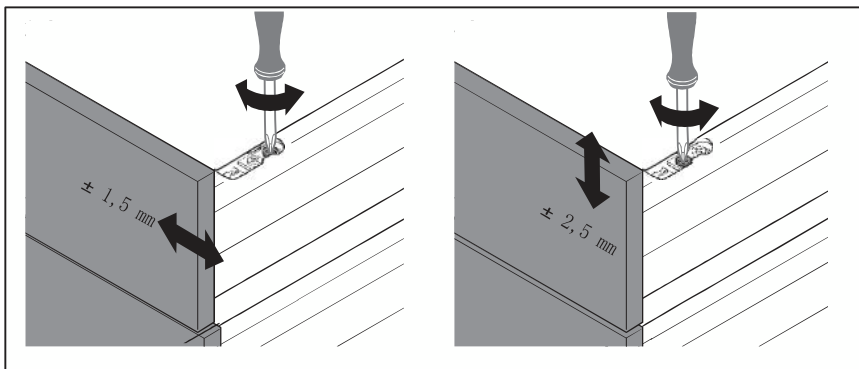

88084.531

01-02-2017

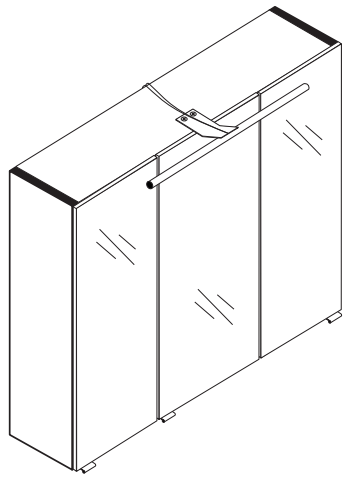

3D-Effekt

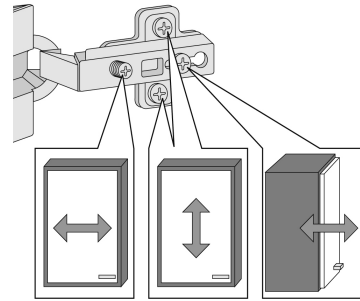
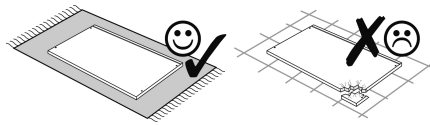
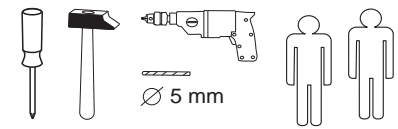
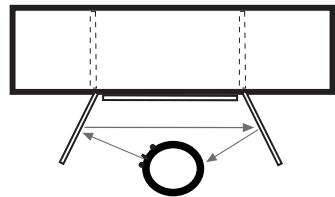

1 4 x 2802	2 4 x 2801	gedämpft 3 x 1506	4 6 x 1614	5 1 x
6 24 x 2819	7 25 x 2862	8 3 x 1098	9 3,0 x 15 6 x 2803	10 4 x 30 4 x 2812
11 5,8 x 55 2 x 2840	12 8 x 30 2 x 2842	13 2 x 2843	14 6 x 2865	15 8 x 30 16 x 2861
16 4,0 x 65/70 2 x 2795	17 1 x 2863	18 3,5 x 15 12 x 2804	19 1 x	
ungedämpft 20 3 x 1507	21 4 x 17 20 x 2832	22 6 x 2552	4 x 3,5 x 15	

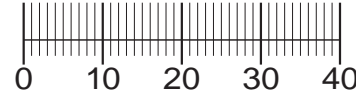

Das beigegefügte Wandbefestigungsmaterial (Dübel und Schrauben) eignet sich nur für festes Mauerwerk (z.B.: Beton- oder Ziegelwände). Für andere Wandaufbauten sind eventuell Spezialdübel und andere Schrauben notwendig. Ziehen Sie gegebenenfalls eine Fachkraft zu Rate.

Приложенный материал для крепления к стене (дюбели и винты) пригоден только для жестких кладок (например, бетонные или кирпичные стены). Для других настенных конструкций необходимы смотря по обстоятельствам специальные дюбели и другие винты. При необходимости проконсультируйтесь у специалиста.

Zalączony materiał do mocowania do ściany (kolki rozprężne i wkręty) nadaje się tylko do ścian murowanych (np. z betonu lub cegieł). Do ścian wykonanych w innych technologiach konieczne być mogą specjalne kolki rozprężne i inne wkręty. W razie potrzeby skorzystaj z fachowej pomocy.

The accompanying wall mounting hardware (anchors and screws) is suitable only for solid masonry (eg concrete or brick walls). For other wall structures are possibly special anchor bolts and other necessary. Tighten if necessary, an expert.

De begeleidende wandmontage hardware (pluggen en schroeven) is alleen geschikt voor massief metselwerk (bijvoorbeeld beton of bakstenen muren). Voor andere muur structuren zijn eventueel bijzondere ankerbouten en andere noodzakelijke. Draai indien nodig, een deskundige.

Le mur d'accompagnement matériel de montage (chevilles et les vis) ne convient que pour la maçonnerie solide (par exemple en béton ou des murs de briques). Pour les structures de mur d'autres sont peut-être spéciale boulons d'ancrage et d'autres nécessaires. Serrer le cas échéant, un expert.

Il muro di accompagnamento hardware di montaggio (tasselli e viti) è adatto solo per muratura piena (ad esempio calcestruzzo o muratura). Per le altre strutture murarie sono forse speciali bulloni di ancoraggio e necessari di altri. Serrare se necessario, un esperto.

Ekteki duvara sabit montaj malzemeleri (dübel ve vidalar), sadece sağlam duvarlar için (örnek: beton veya tuğla) elverişlidir. Başka duvarlar için özel dübeller ve farklı vidalar gerekebilir. Gerektiğinde bir bilene danışınız.

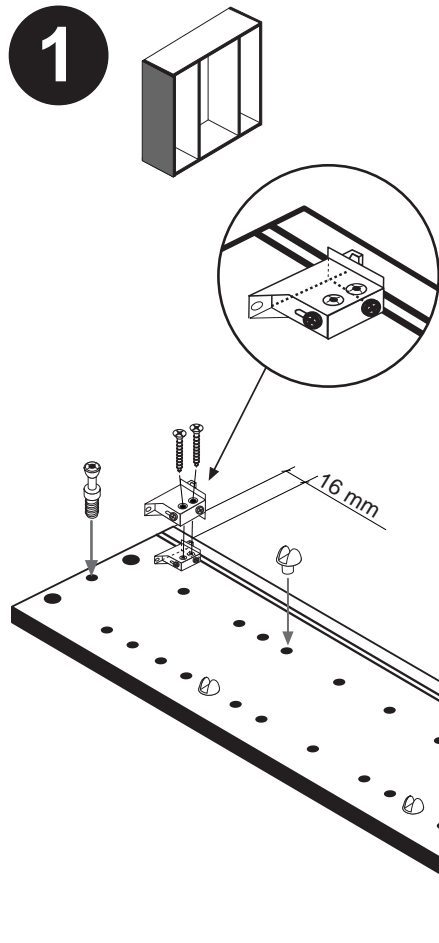
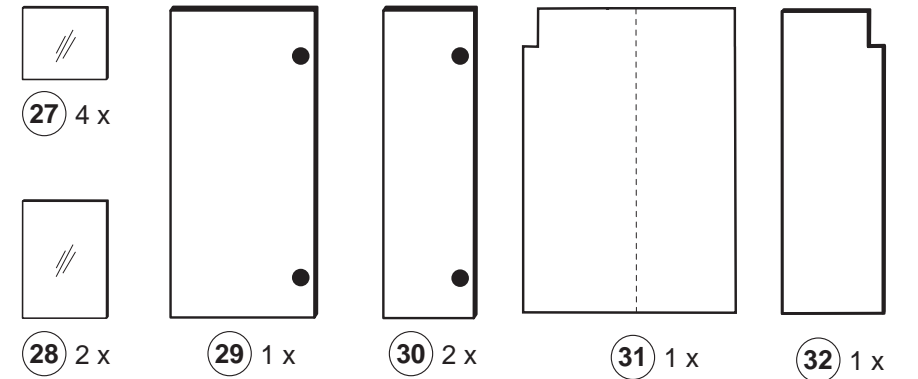
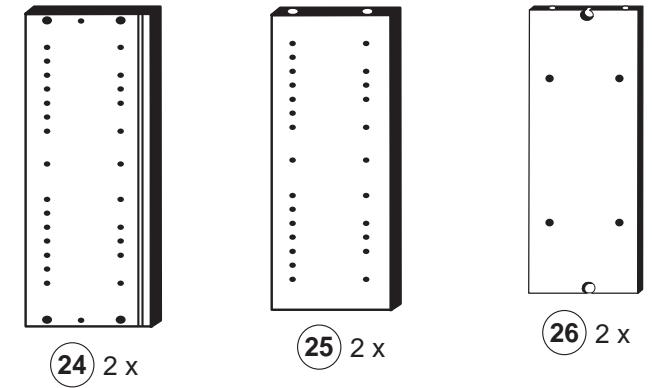

1 4 x 2802	6 8 x 2819
10 4 x 30 4 x 2812	13 2 x 2843

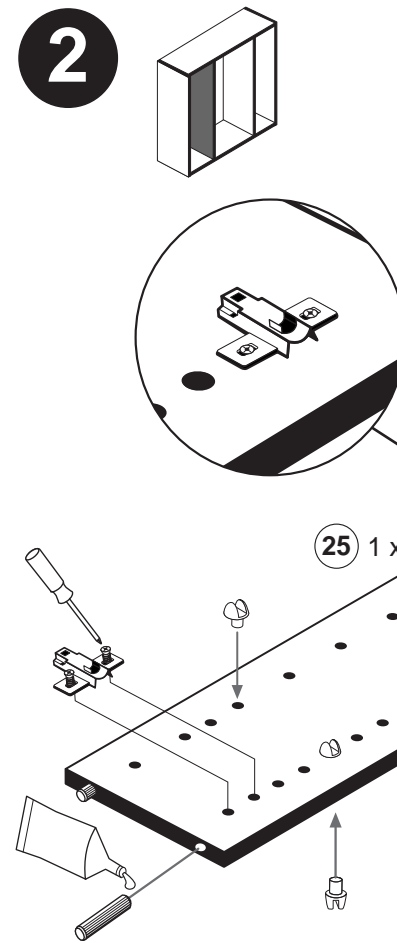
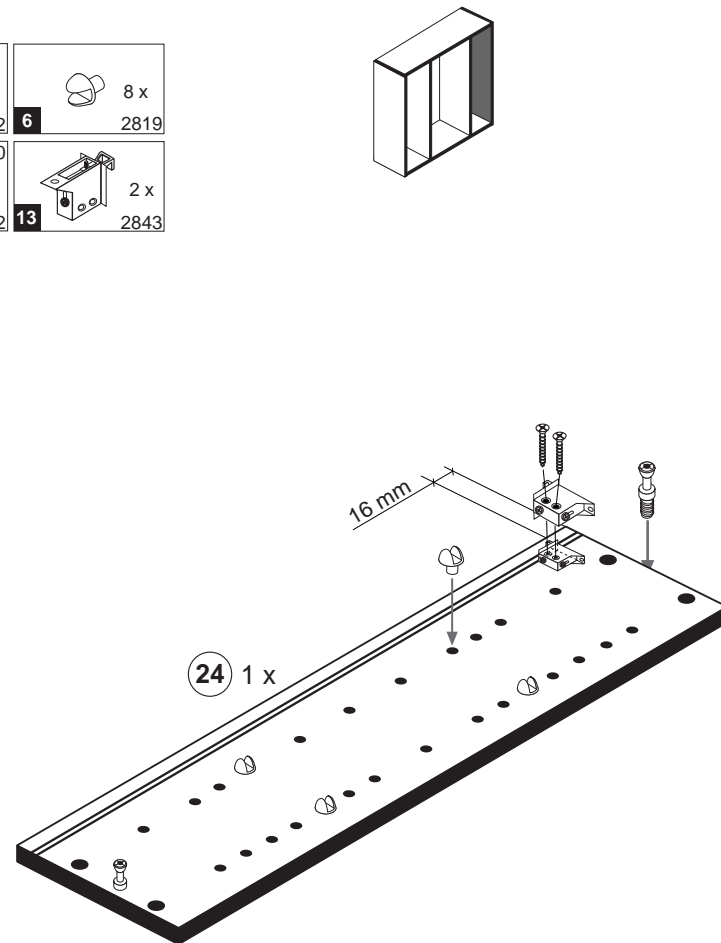

4 6 x 1614	15 8 x 30 8 x 2861
6 16 x 2819	17 1 x 2863

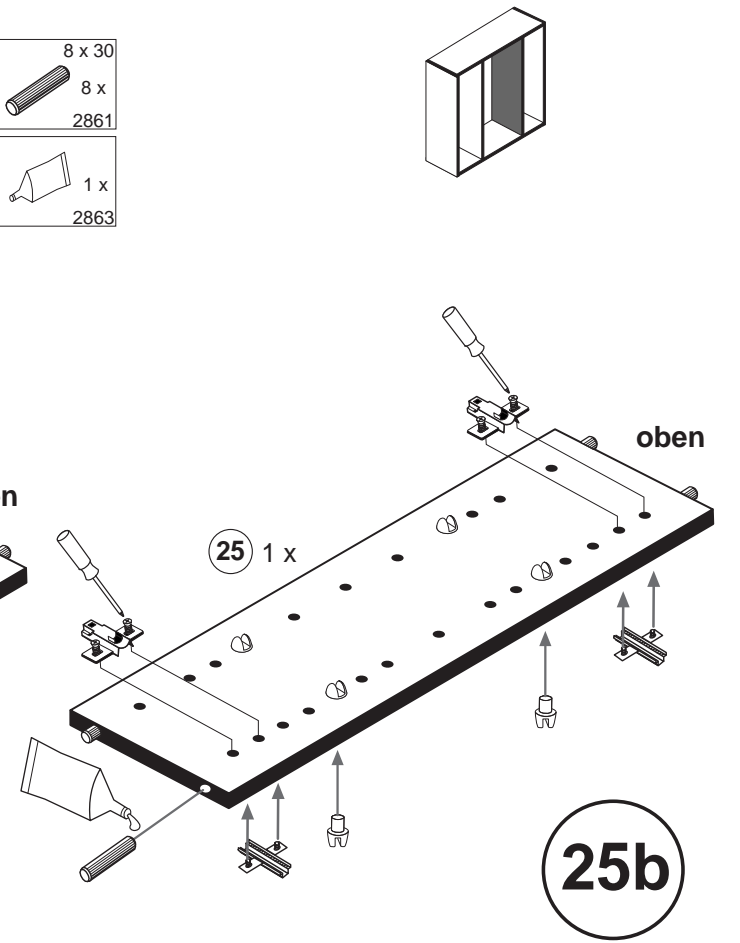

3

17	1 x	2863	2	4 x	2801
				8 x 30	
			15	8 x	2861

4

17	1 x	2863
----	-----	------

D Leim
GB Glue
NL Lijm
PL Klej
TR Tutkal
F Colle
I Colla

20 min.

5

Variante 1: Trafomontage unten

Variante 2: Trafomontage oben

Die Montage der elektrischen Teile und Verbindungen sind unter Berücksichtigung der VDE 0100 Teil 701 von einer Fachkraft des Elektrohandwerks vorzunehmen.

Sie können die Position der Trafobox frei wählen. Sägen Sie an der ausgewählten Position eine Aussklung für die Kabel aus.

Bitte nur einen Ausschnitt aussägen. (Montagevariante)

1.

2.

Variante1 Trafomontage unten

Variante2 Trafomontage oben

16	2 x	2795
5	1 x	

4,0 x 65/70

21	20 x	2832
22	6 x	2552

6

7

gedämpft	ungedämpft
3	20
3 x	3 x
1506	1507
14	18
6 x	3,5 x 15
2865	12 x
	2804

8

Montieren Sie die Aufbauleuchte mittig auf dem Schrank!

19

1 x

4 x

1 x

9

8	3 x	1098
9	6 x	2803

3,0 x 15

8 mm

5 mm

10

11	2 x	2840
12	2 x	2842

5,8 x 55

8 x 30

**D****Wichtige Sicherheitshinweise**

Die Installation Ihrer neuen Leuchte darf ausschließlich von autorisierten Fachpersonen durchgeführt werden

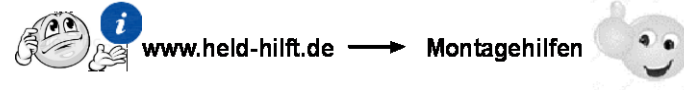
**GB****Important safety instructions**

The installation of your new luminaire may only be carried out by authorized specialists.

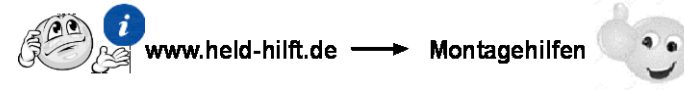
**FR****Consignes de sécurité importantes**

La L'installation votre nouveau luminaire doit uniquement être réalisée par des spécialistes autorisés

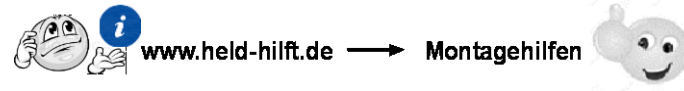
**IT****Importanti disposizioni di sicurezza**

l'installazione della il loro nuovo lampada può essere eseguita solo ed esclusivamente da personale tecnico autorizzato.

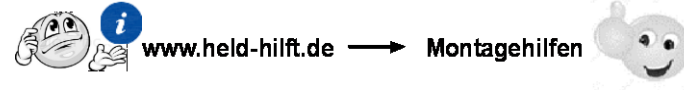
**NL****Belangrijke veiligheidsaanwijzingen**

De installatie van de nieuwe lamp moet worden uitgevoerd door vakbekwame personen worden uitgevoerd.

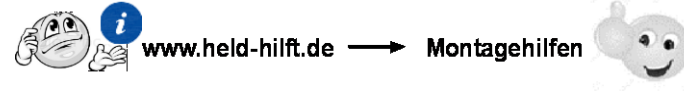
**CZ****Důležité bezpečnostní pokyny**

Instalaci nových svítidel smí provádět pouze kvalifikovaný elektrikář.

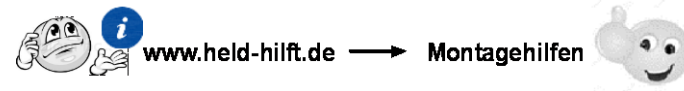
**PL****Ważne wskazówki dotyczące bezpieczeństwa**

Ta Instalację nowej lampy mogą przeprowadzać wyłącznie autoryzowani instalatorzy

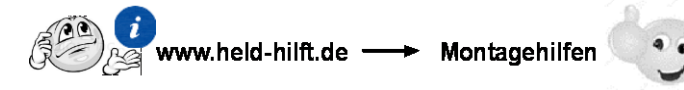
**SK****Dôležité bezpečnostné upozornenia**

Inštaláciu lampy smú vykonať výhradne autorizovaní

**HU****Fontos biztonsági utmutatások**

Az On Új lámpájának beszerelését kizárólag hivatalos szakember végezheti el

**RO****Instrucțiuni de siguranță importante**

Instalarea noii dumneavoastră lămpi este permisă exclusiv specialiștilor autorizați

**TR****Önemli güvenlik uyarıları**

Yeni lamba montajı yetkin kişiler tarafından yapılmalıdır

**RU****важная информация по технике безопасности**

Установка вашей новой лампы должна выполняться квалифицированным персоналом

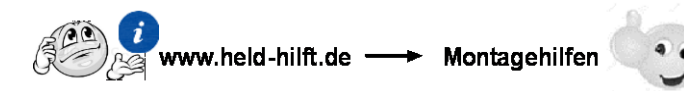

89904.330