

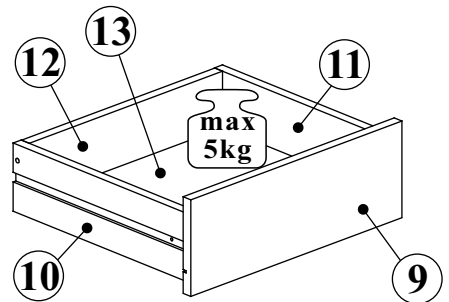

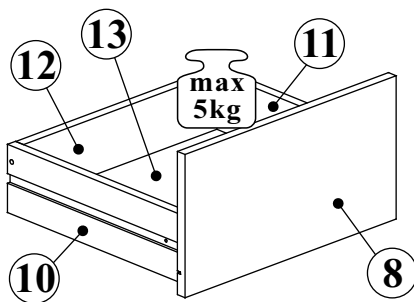

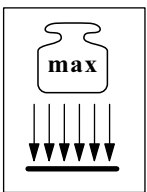

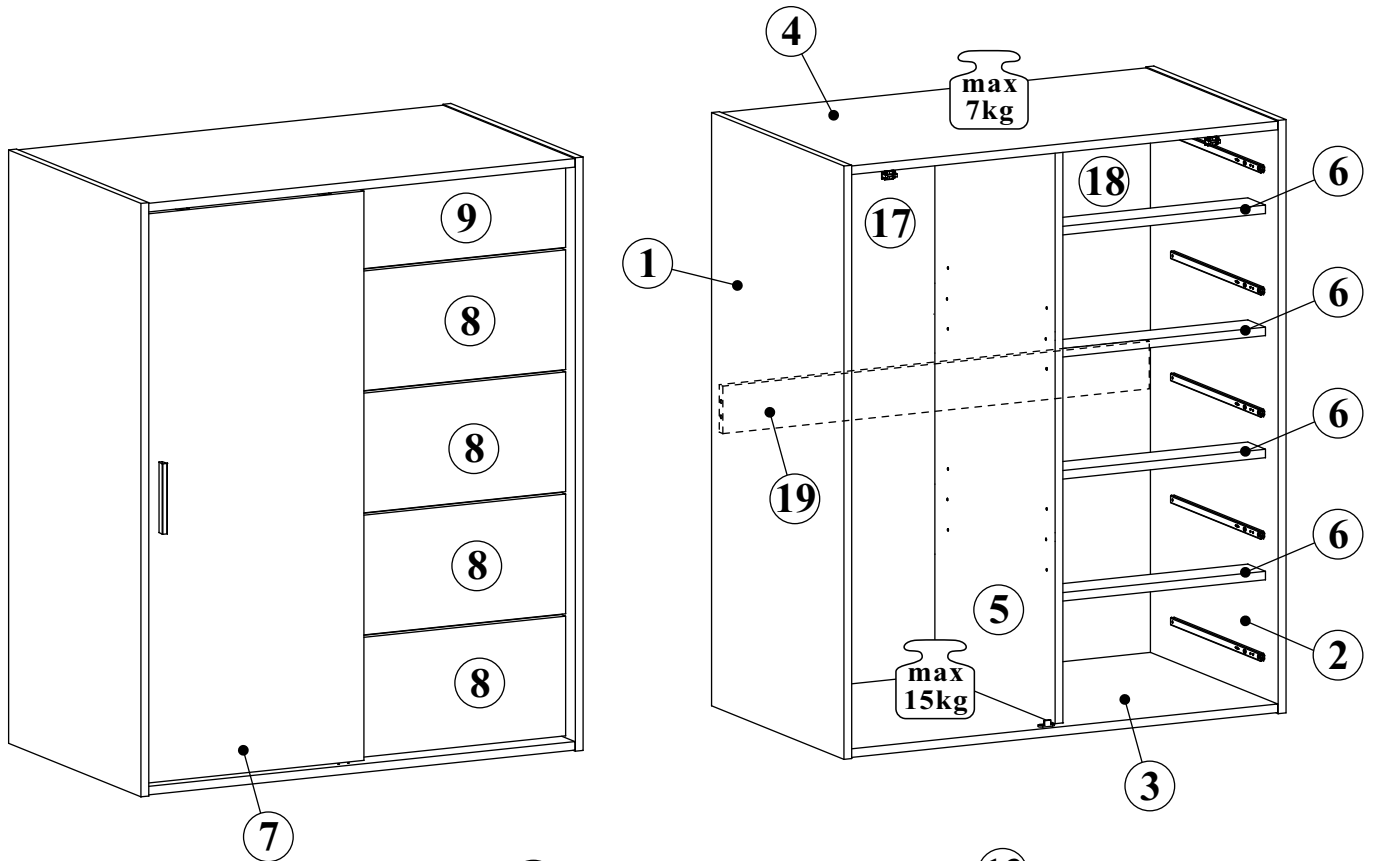

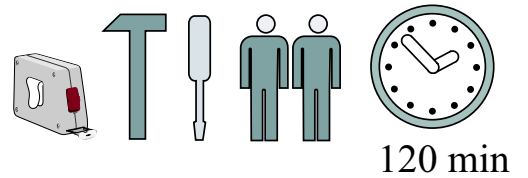

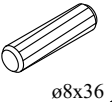
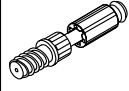



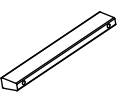

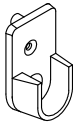
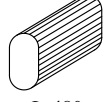



CASE 38-310-__

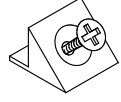
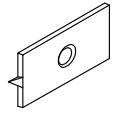

NO	Dim.			Col.-No	Qty
1	1249	600	18	1	1
2	1249	600	18	1	1
3	986	598	18	2	1
4	986	598	18	2	1
5	1209	545	18	1	1
6	480	80	18	2	4
7	1198	500	18	3	1
8	474	252	18	3	4
9	474	170	18	3	1
10	400	120	18	2	5
11	400	120	18	2	5
12	434	100	18	2	5
13	404	446	3	2	5
17	1221	502	3	1	1
18	1221	494	3	1	1
19	986	100	16	2	1

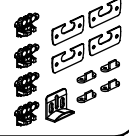

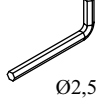
CASE 38-310-__

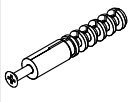
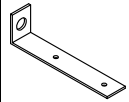
A1 x54  ø8x36	B4 x38 	B5 x38  Ø15x12	G5 x38 	B11 x10  Ø7x50	G4 x10 
U17 x1 	UP6 x2  UPØ4x30	G10 x2 	C5 x1  L-480mm	D10 x22  USØ3,5x13	OD1 x5 
H6 x5  L-406	D20 x30  ESØ6x9,5	D33 x10  M4x16	S1 x21 	G16 x8 	UP13 x23  UPØ3x16
I11 x5  Ø50, h=25	UP15 x5  UPØ4x25	SL x1 	EK6 x2  EKØ6,3x13	G22 x1  Ø2,5	G2 x1 
KR1 x2 	L1 x2 				

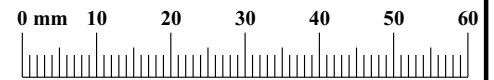

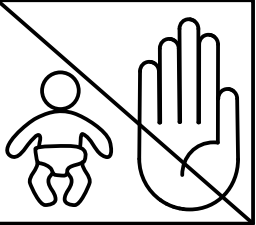

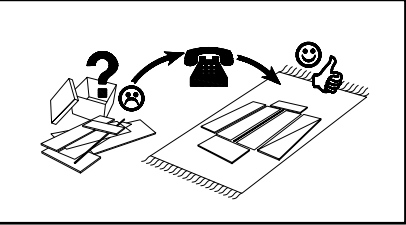

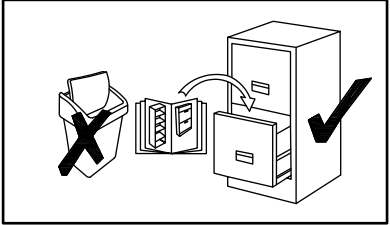

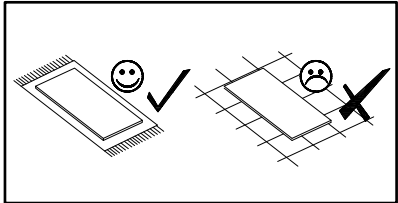

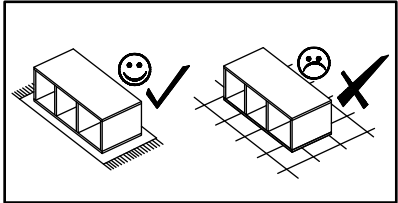

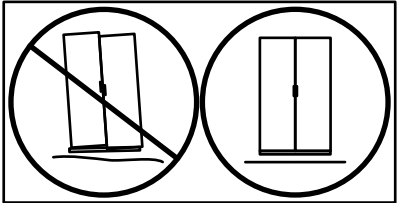

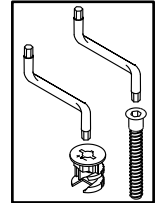







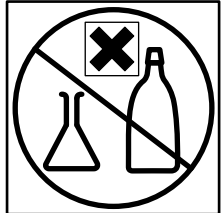

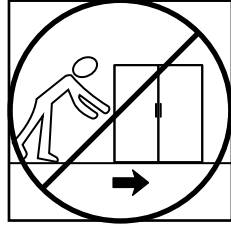

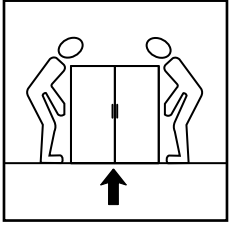

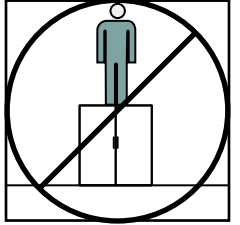

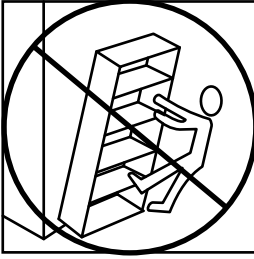

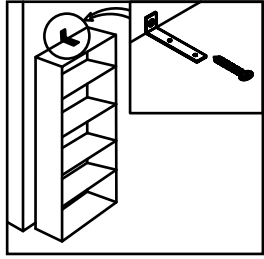

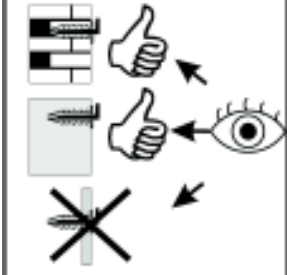



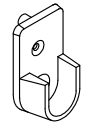
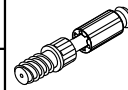

D10		G10		B4	
x1	USØ3,5x13	x1		x7	

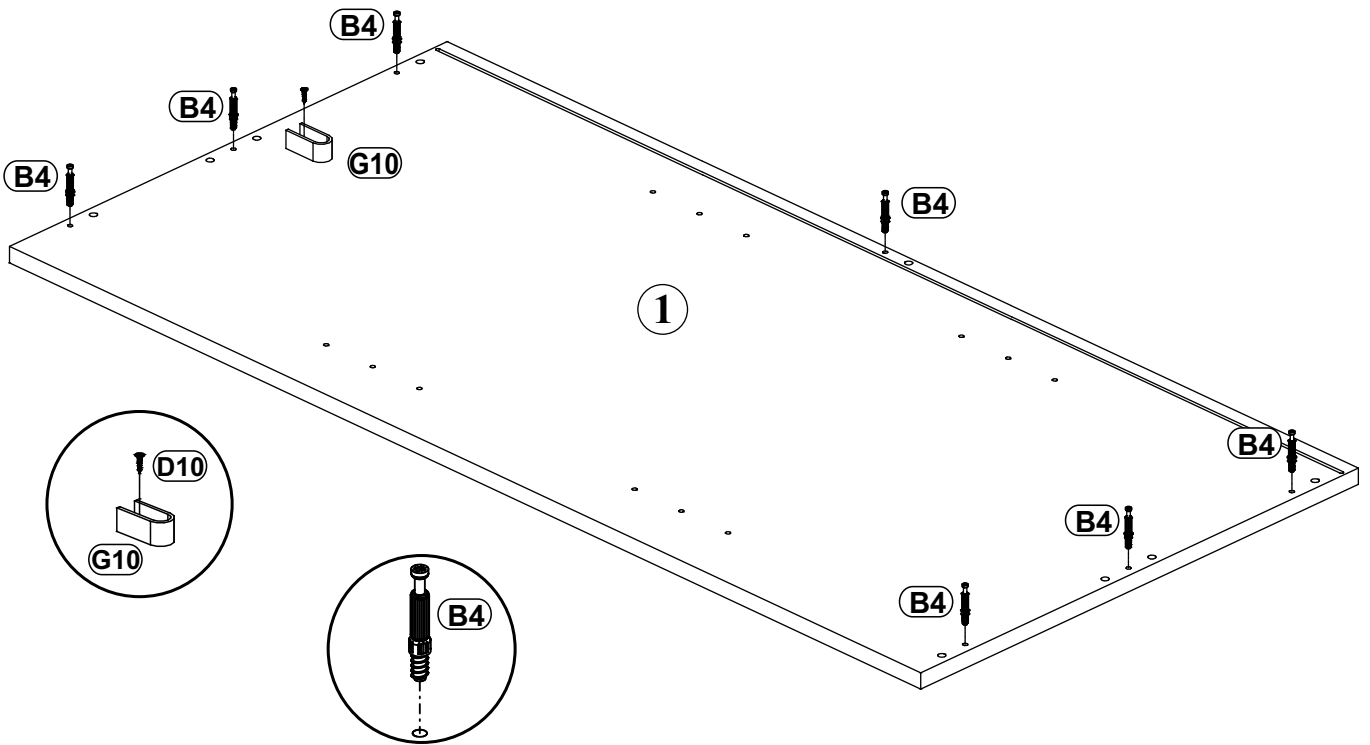
1



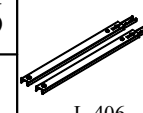
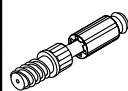

2

H6		B4	
x5	L-406	x11	

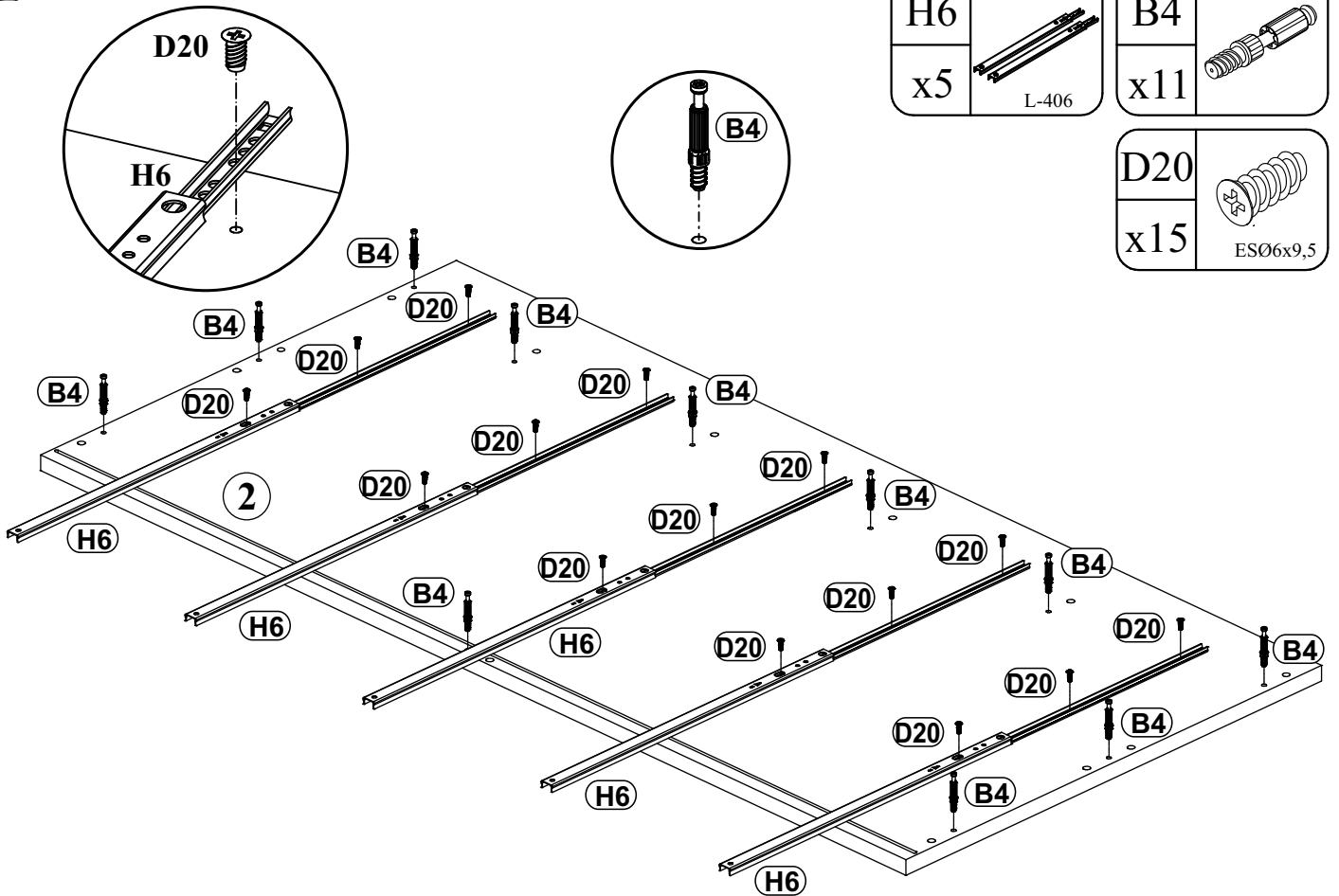
D20	
x15	ESØ6x9,5

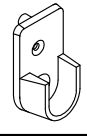
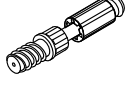
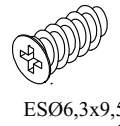
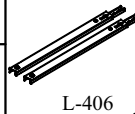

3

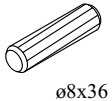
D10 x1	 USØ3,5x13	G10 x1		B4 x4	
D20 x15	 ESØ6,3x9,5	H6 x5	 L-406	B5 x6	 Ø15x12
A1 x8					 ø8x36

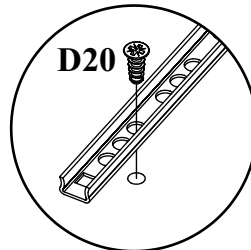
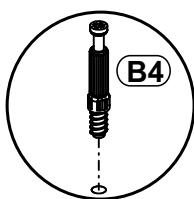
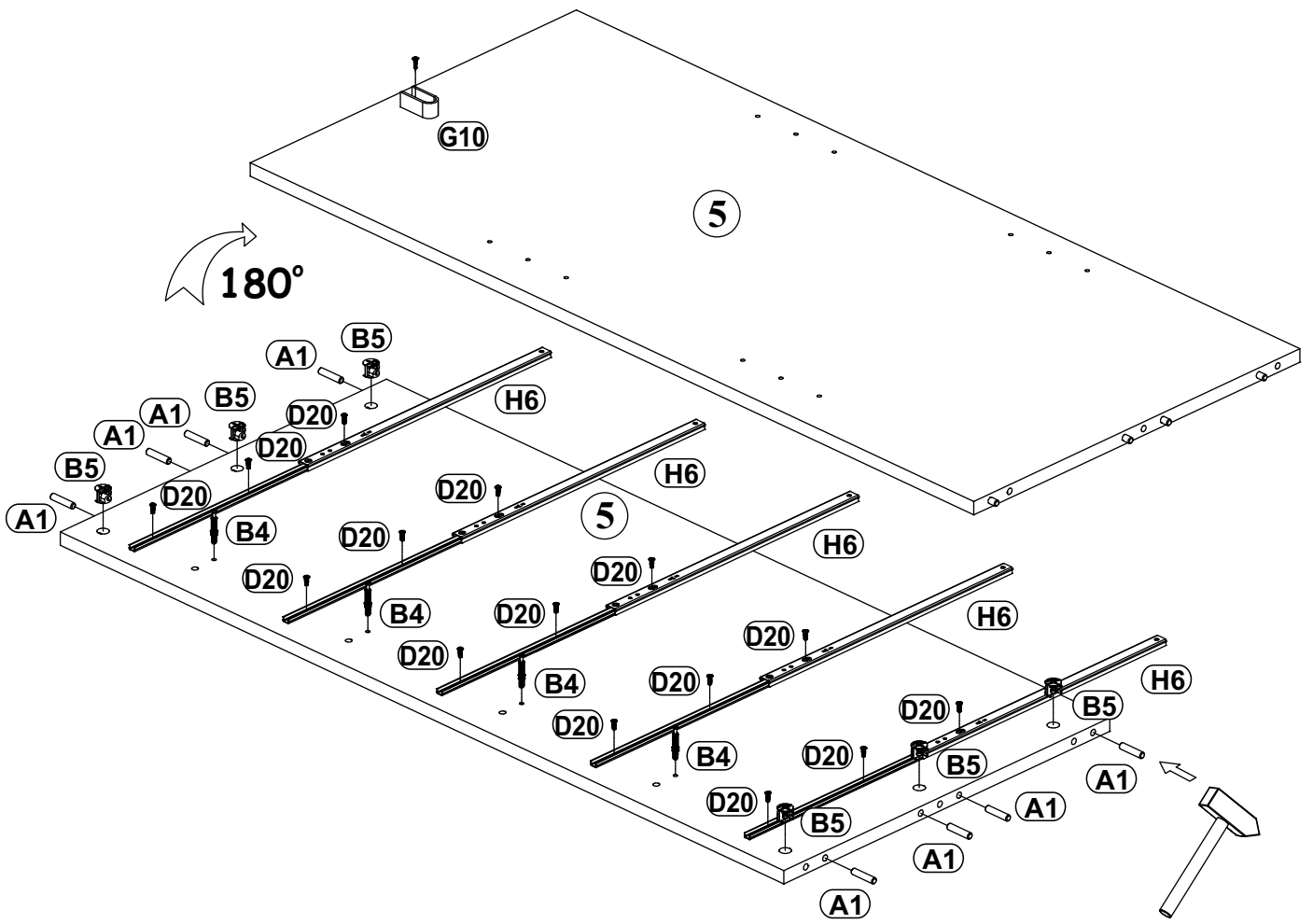
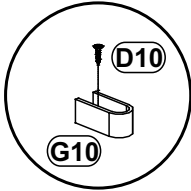

4

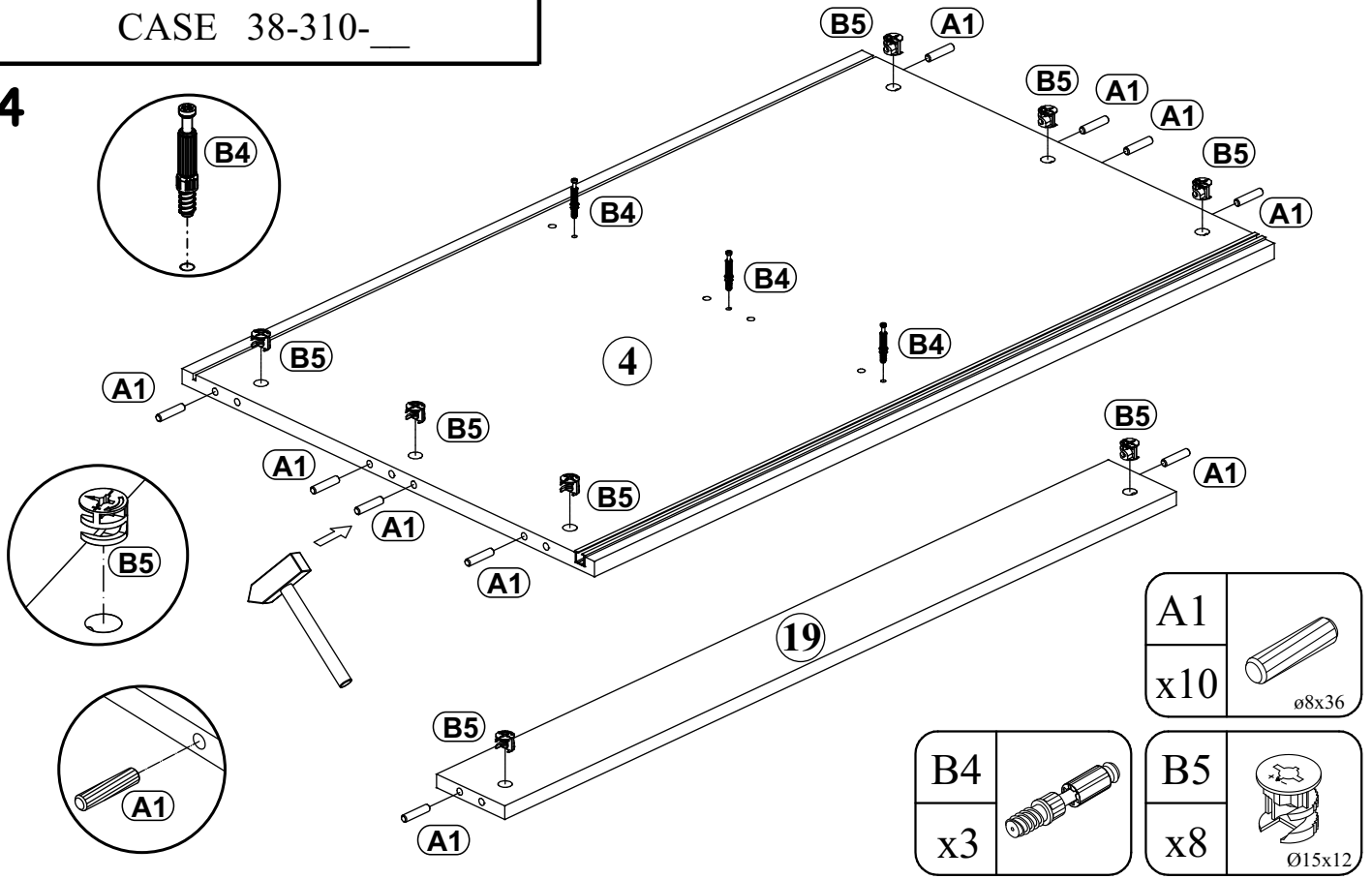

5

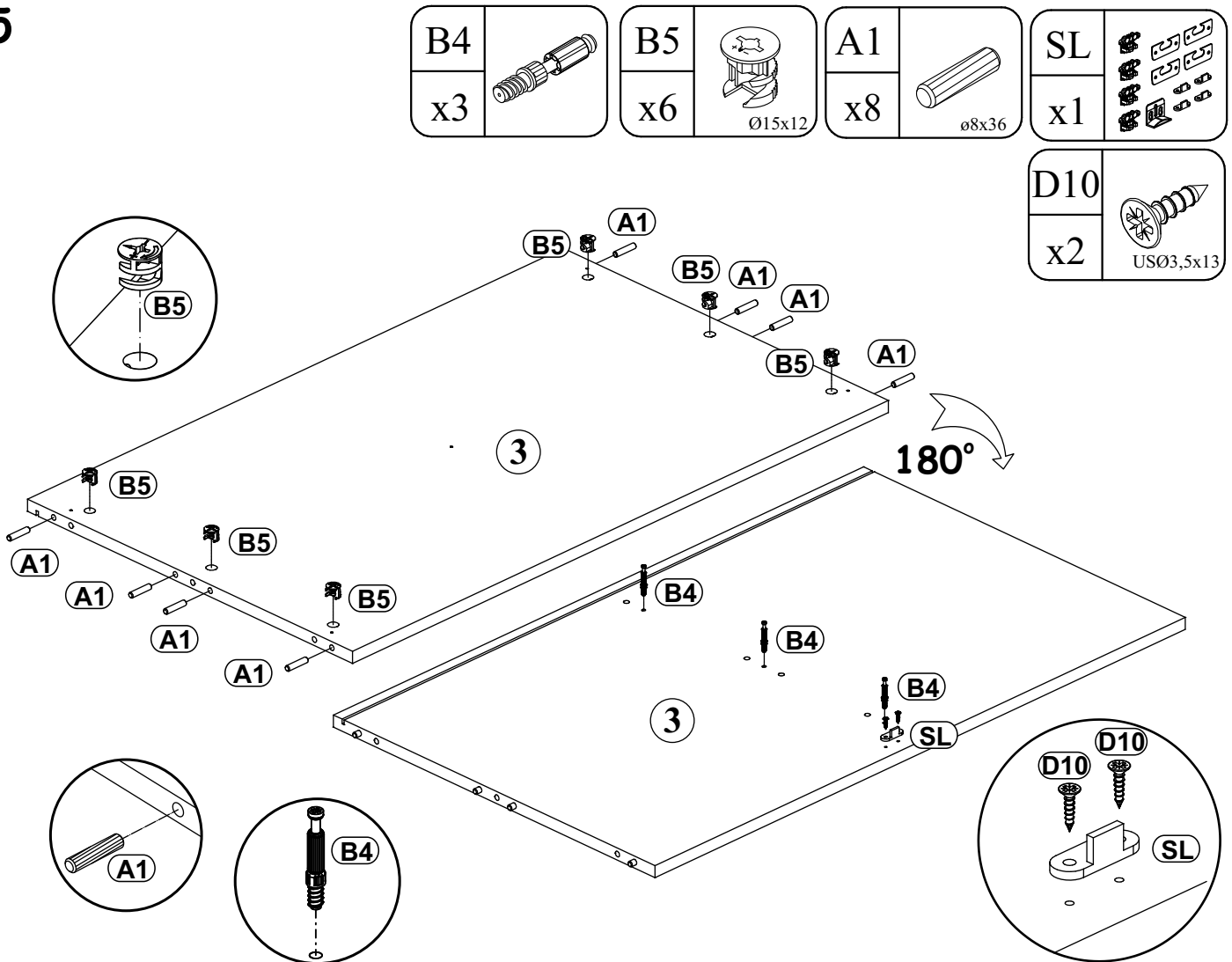

6

A1	
x8	ø8x36

B5	
x8	Ø15x12

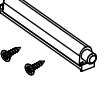
OD1	
x5	

D10	
x10	USØ3,5x13

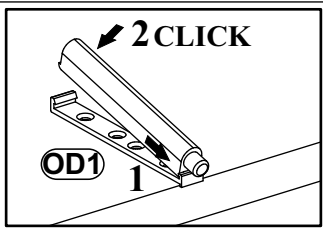
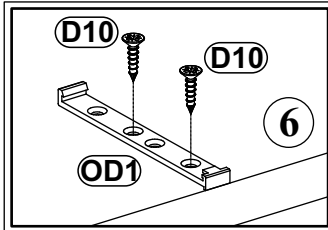
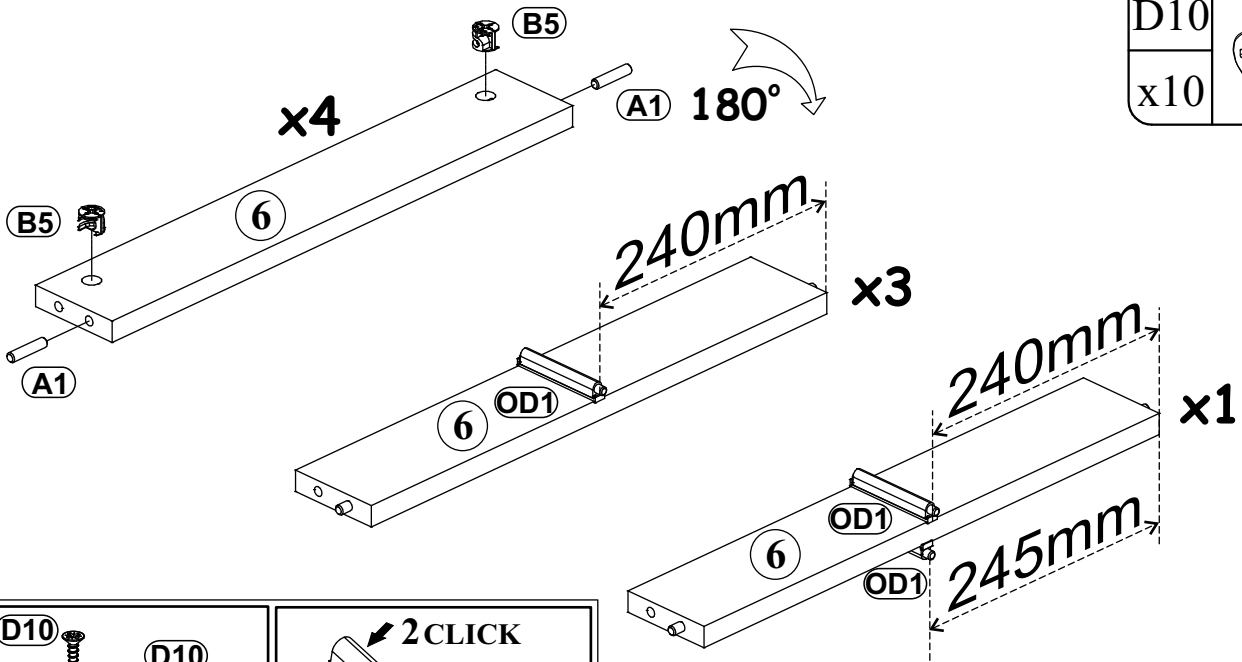

7

A1	
x20	ø8x36

B5	
x10	Ø15x12

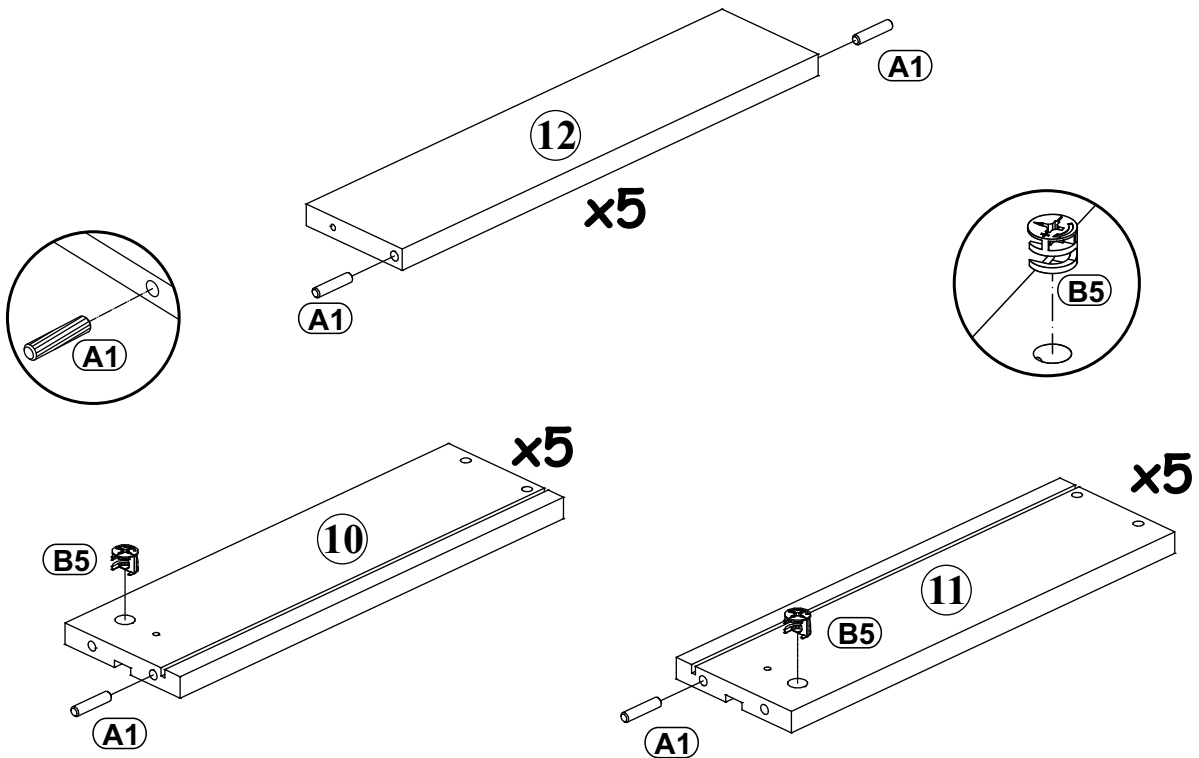

8

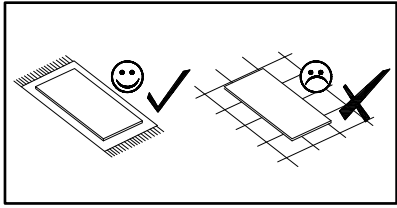

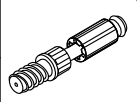

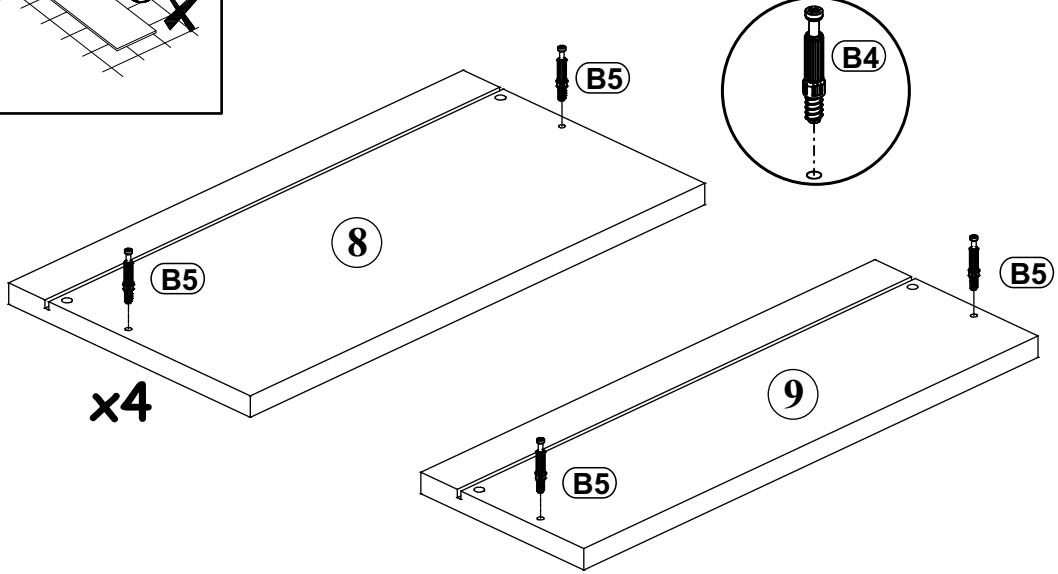
B4	
x10	

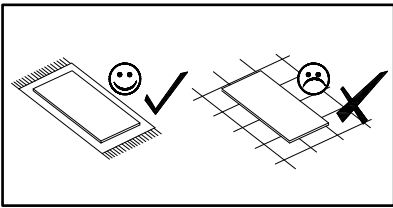

9

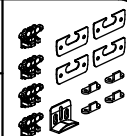

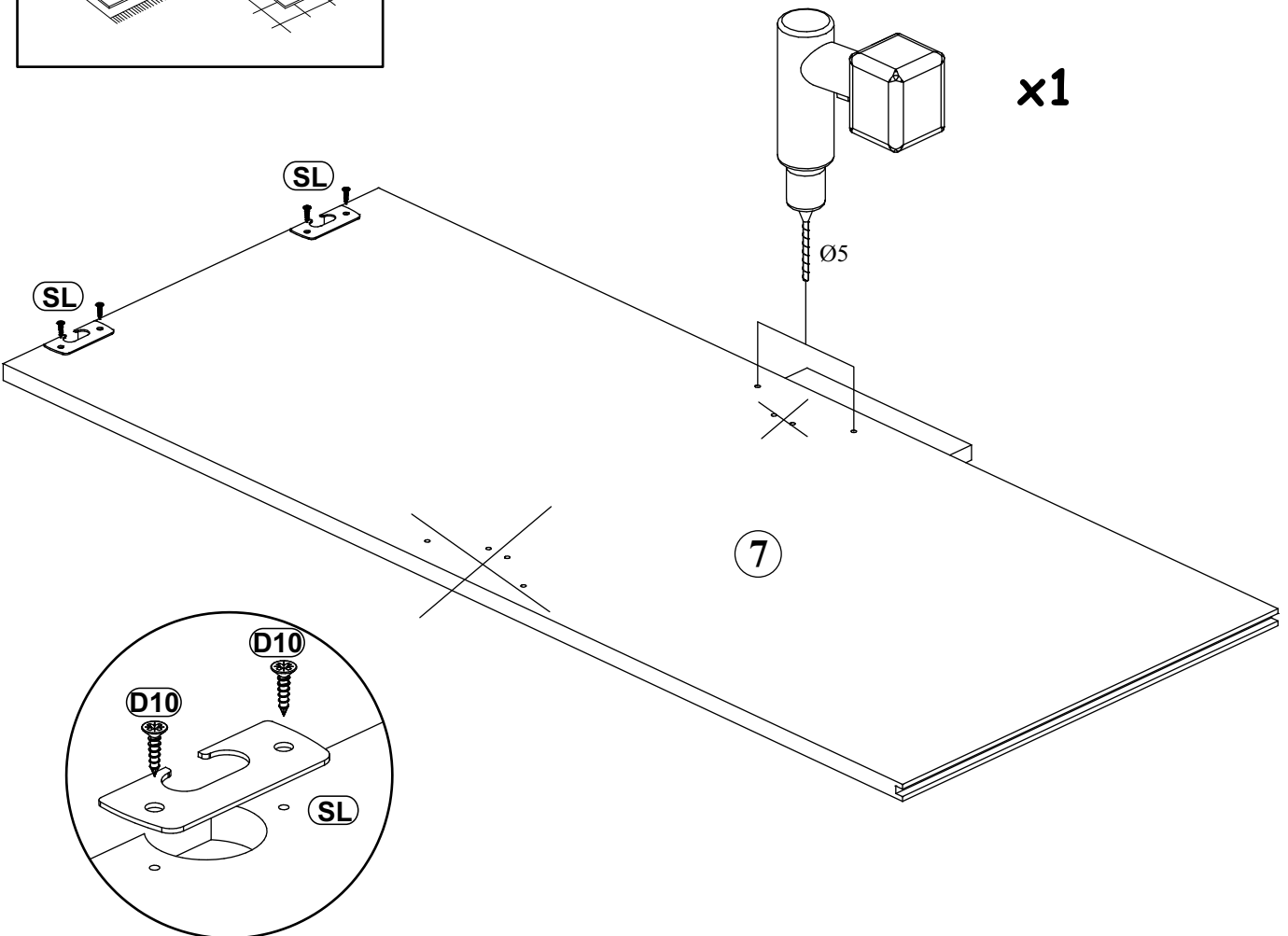

SL		D10	
x1		x4	USØ3,5x13

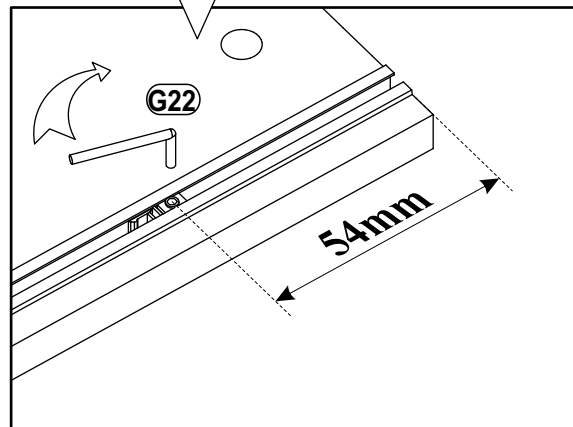
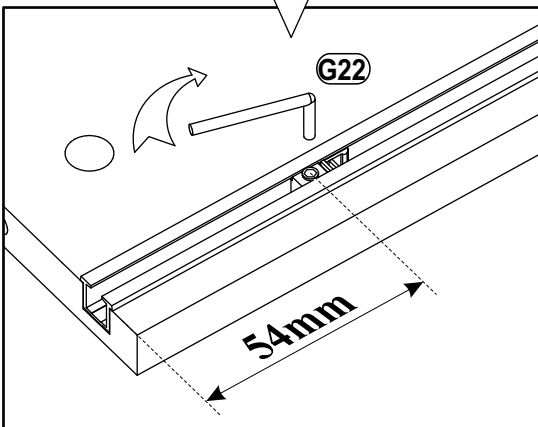
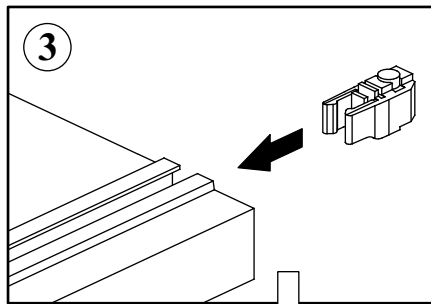
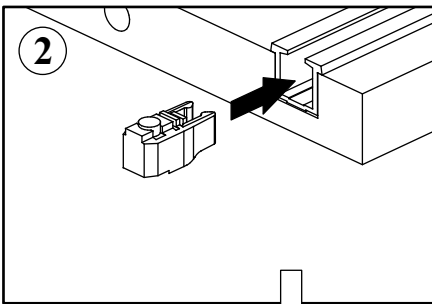
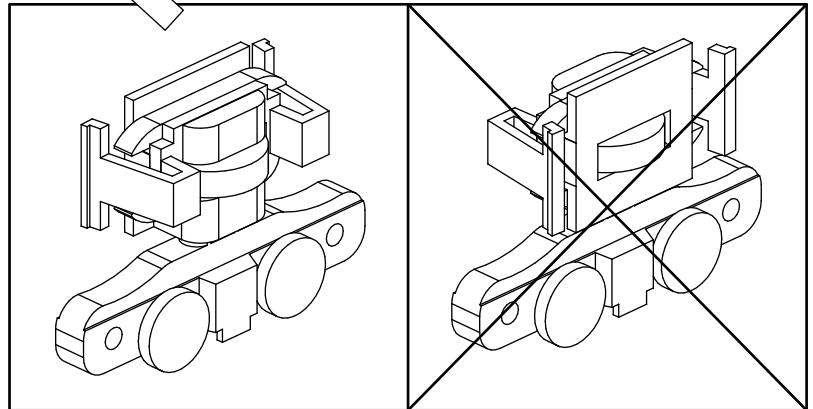
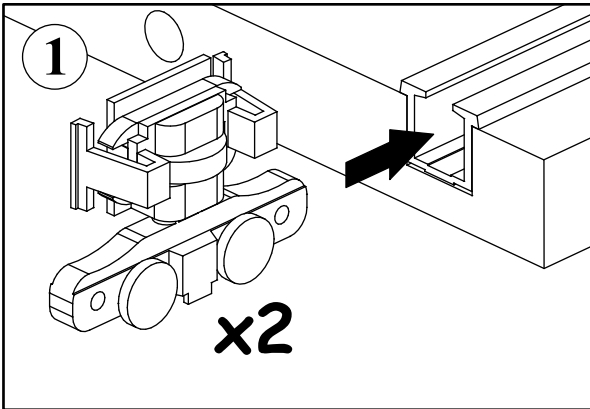
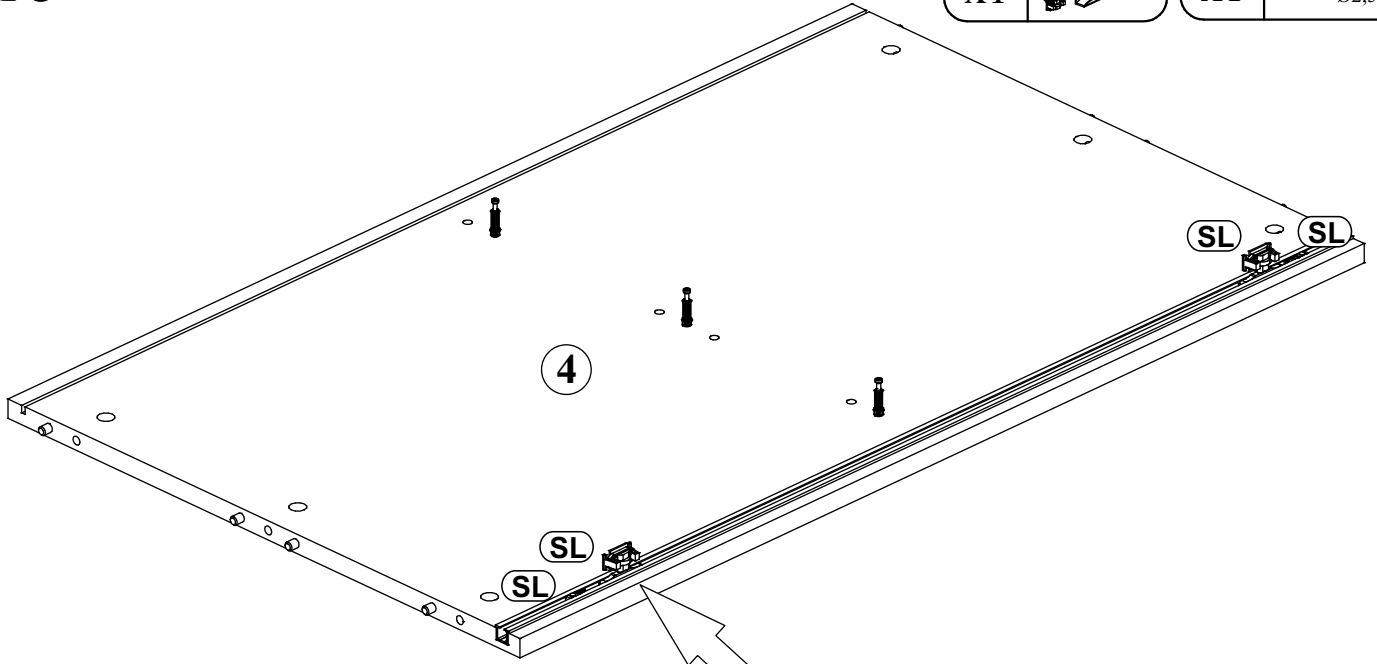

SL		G22	
x1		x1	Ø2,5

10



G4	
x10	

B11	
x10	Ø7x50

11

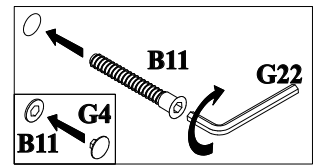
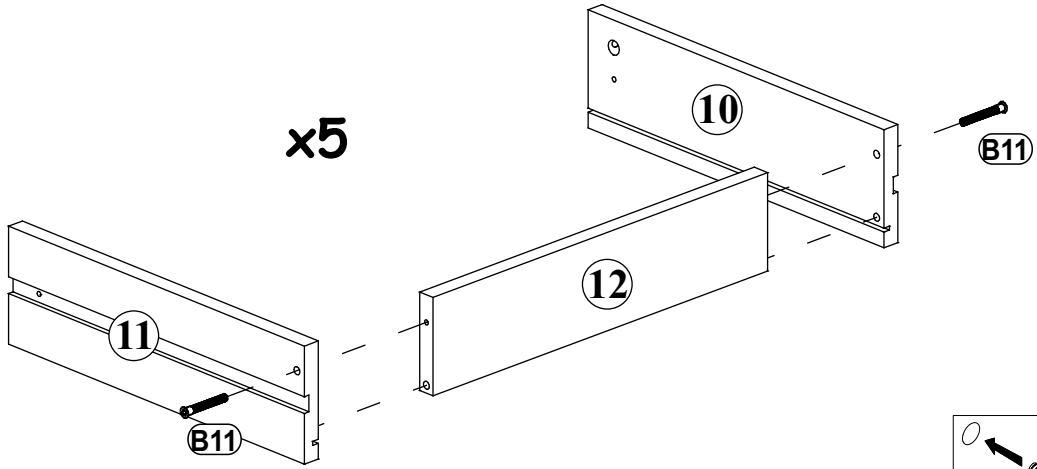

12

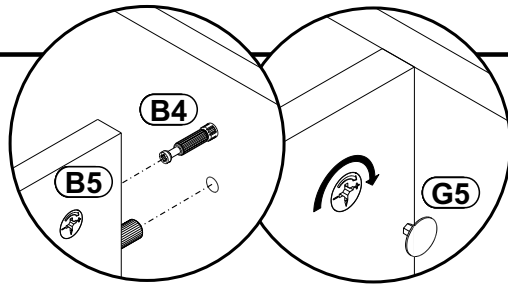

G5	
x10	

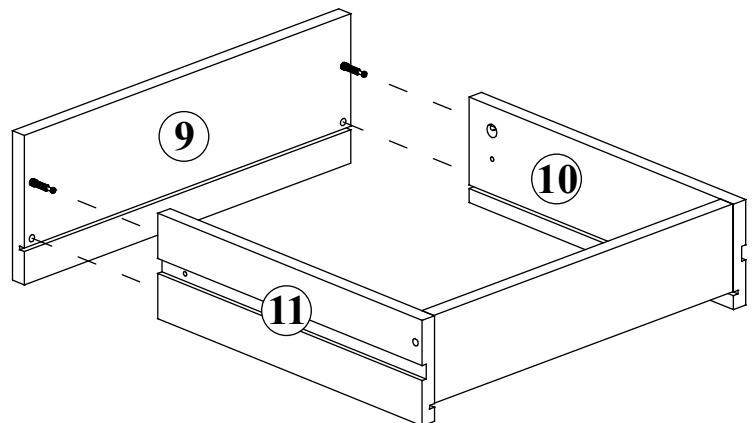
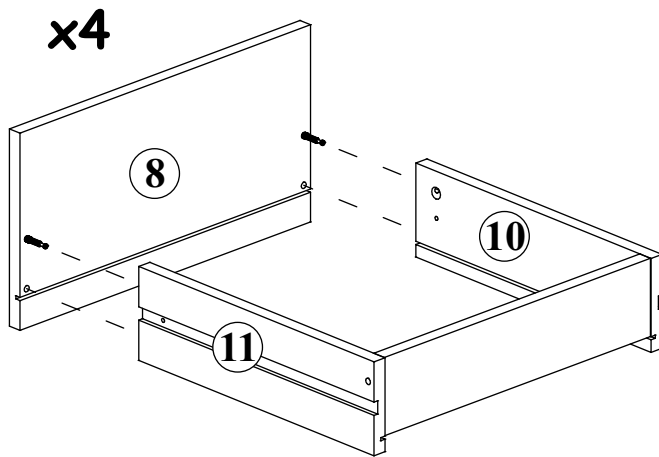

13

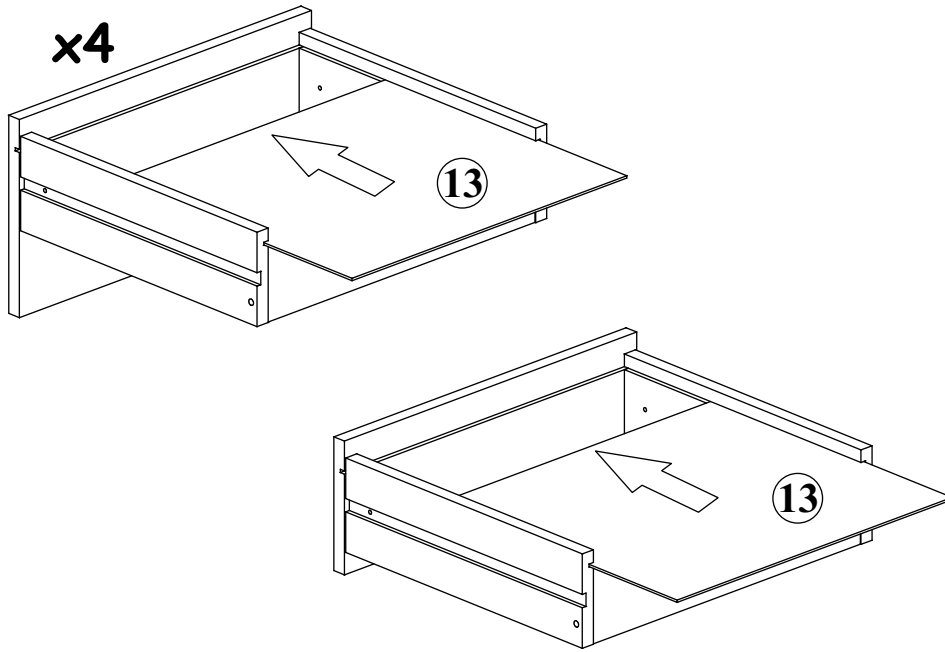

14

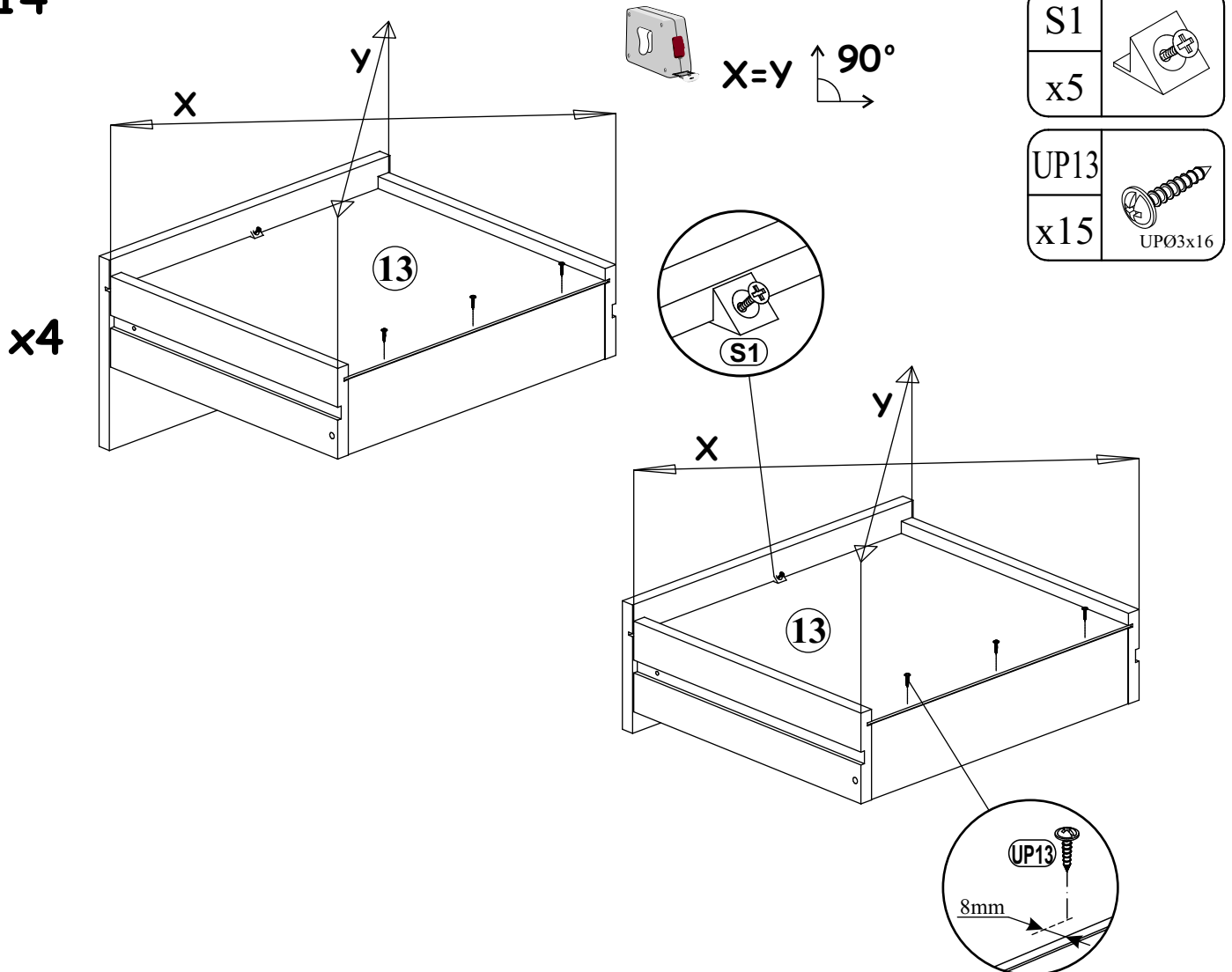

15

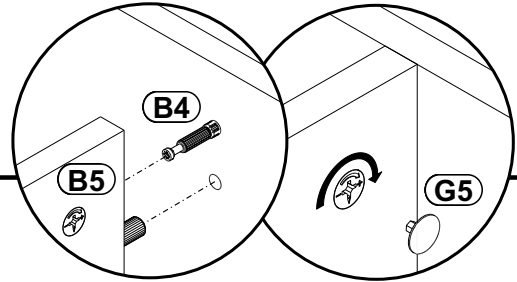
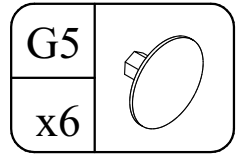
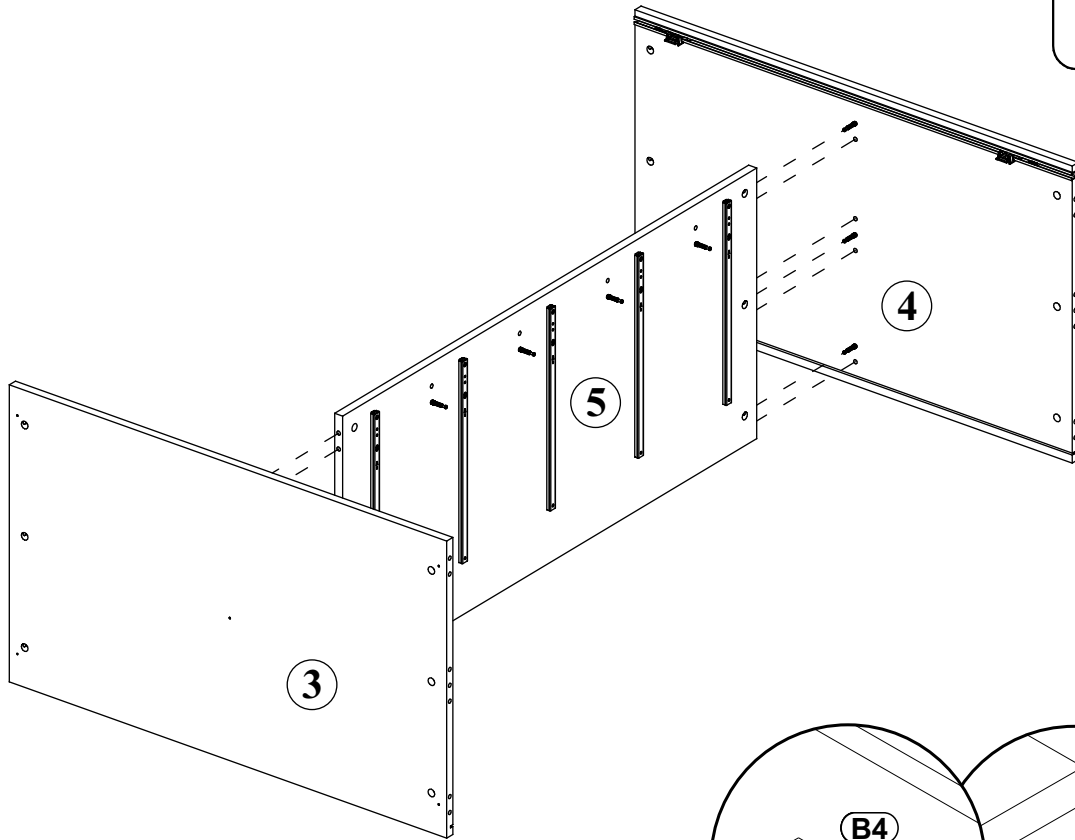

16

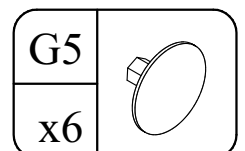
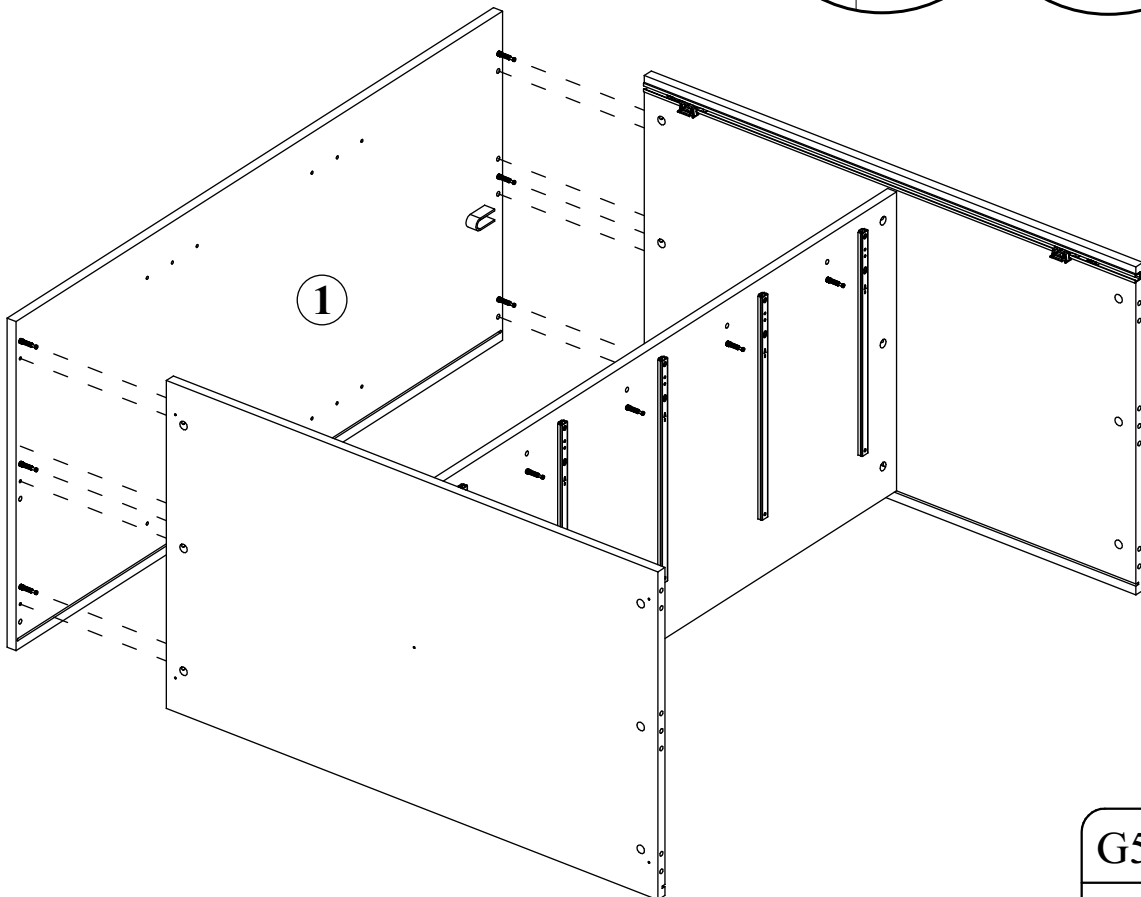

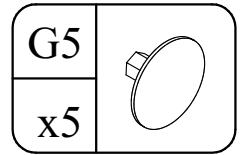
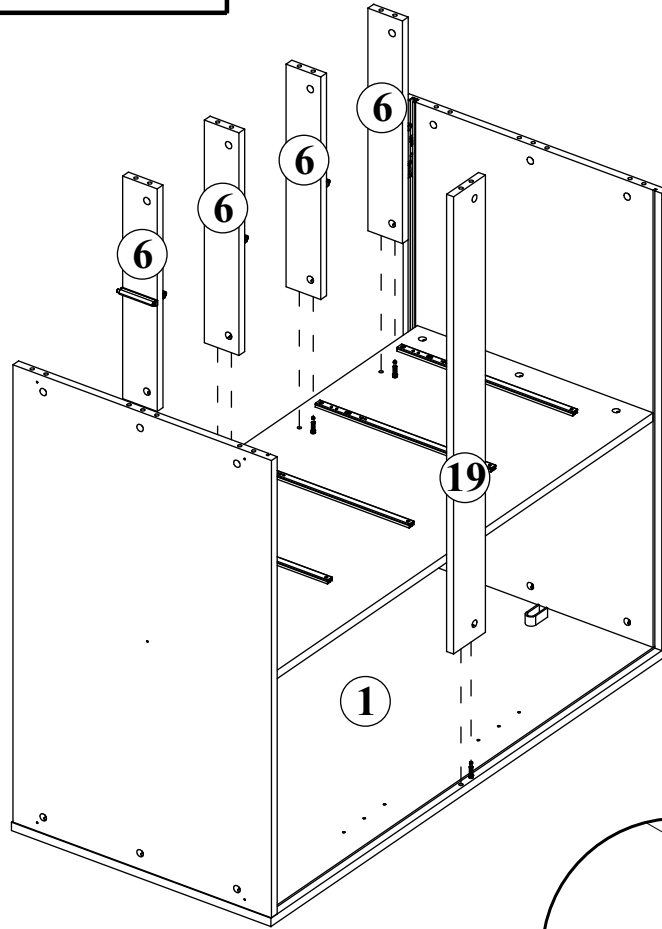

17

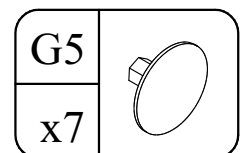
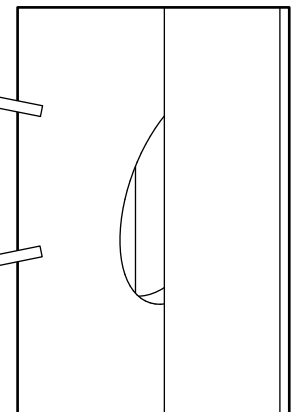
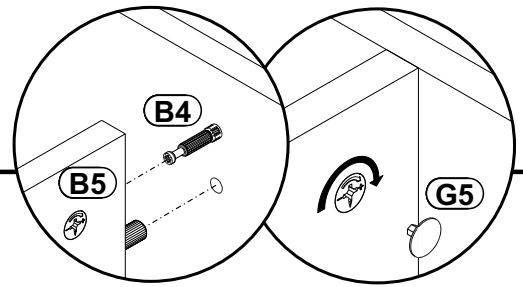
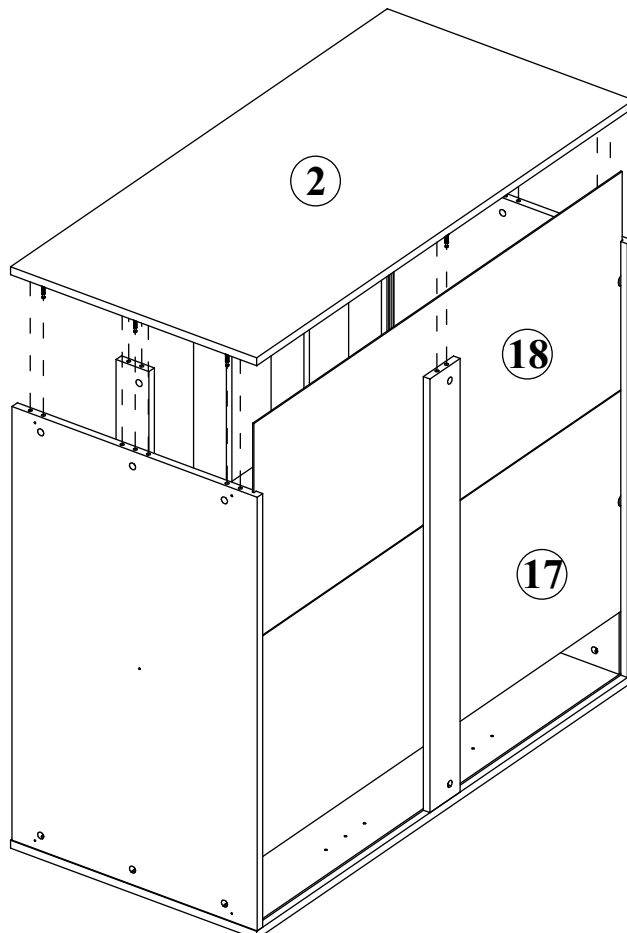

18



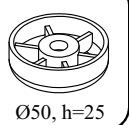
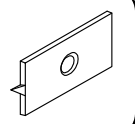

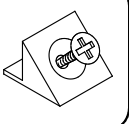
19

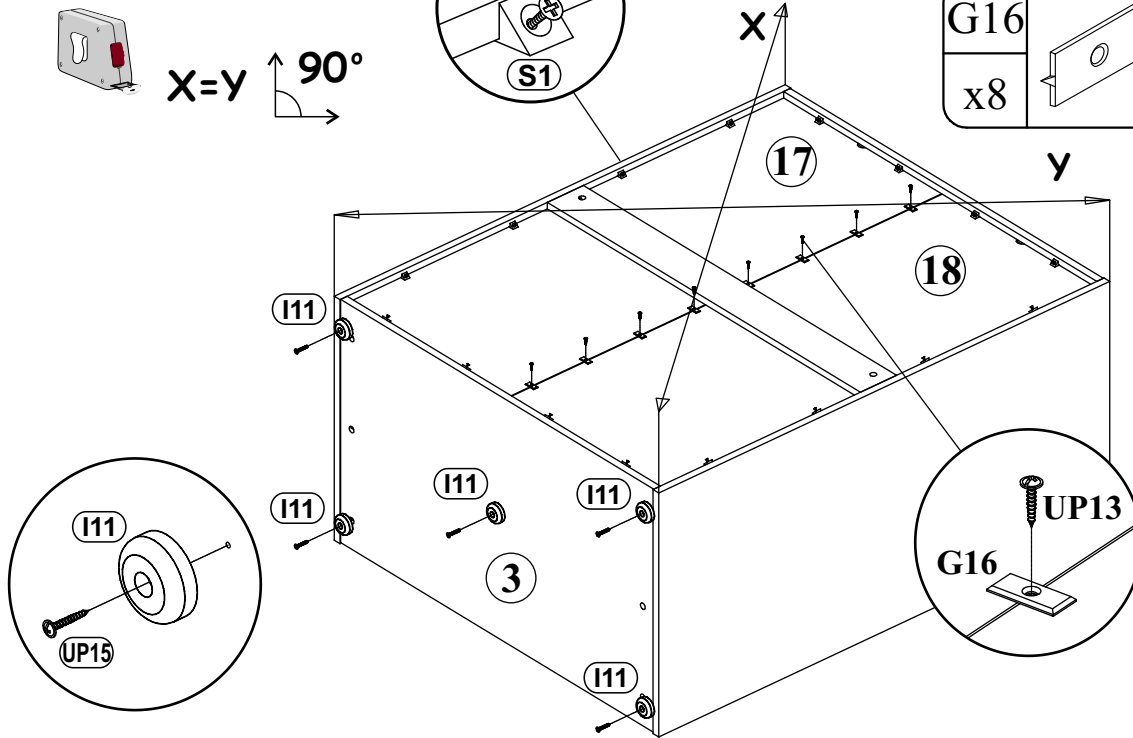
UP15 x5	 UPØ4x25	I11 x5	 Ø50, h=25
G16 x8		UP13 x8	 UPØ3x16
		S1 x16	

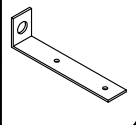

20

L1 x2	
KR1 x2	
D10 x4	 USØ3,5x13

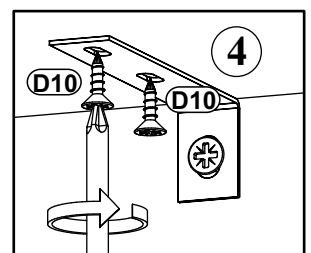
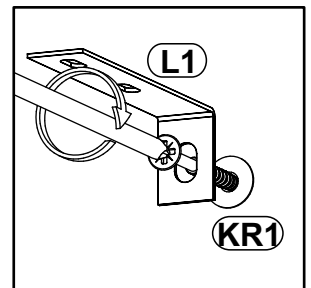
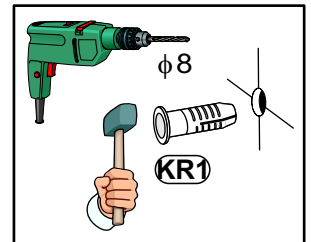
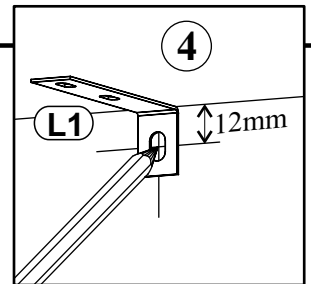
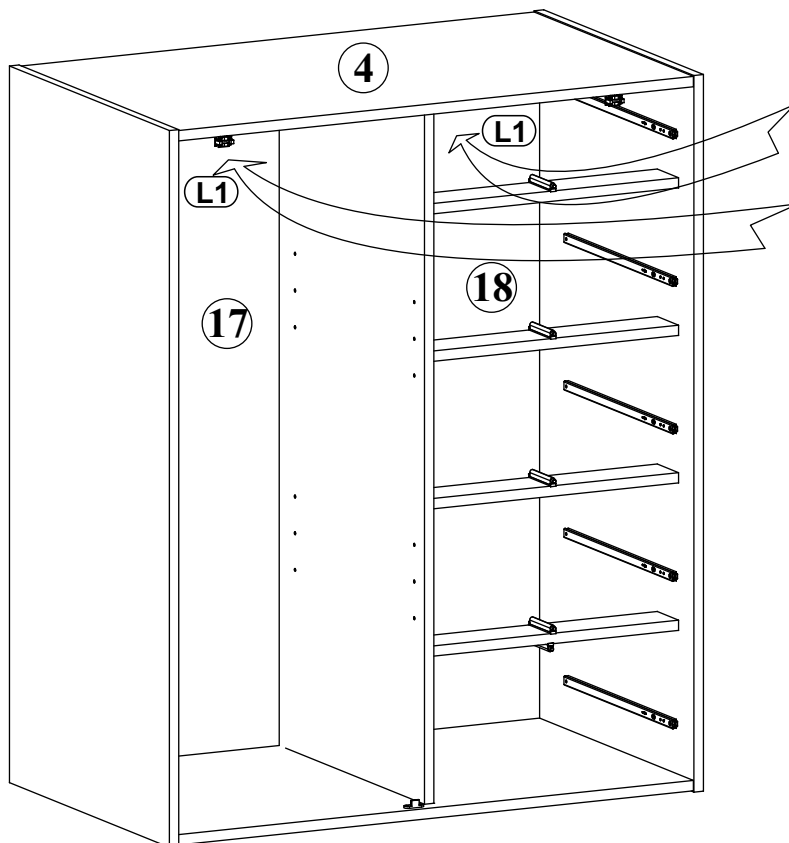

21

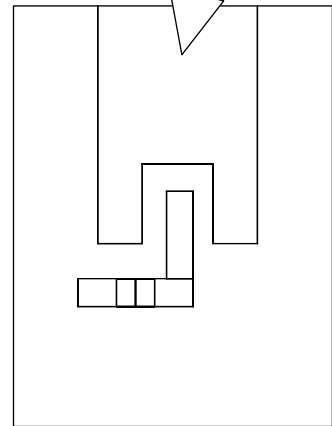
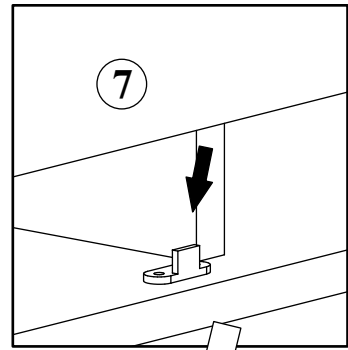
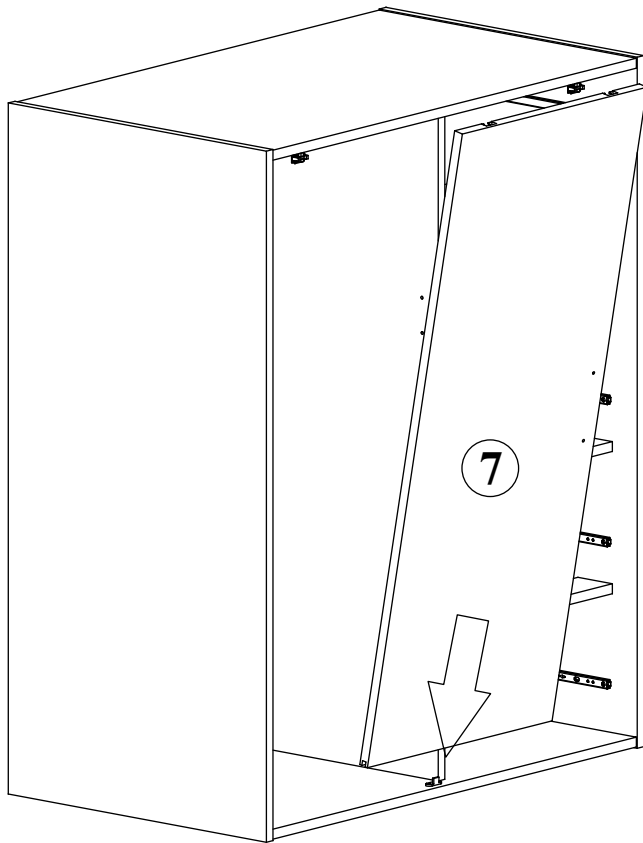

22

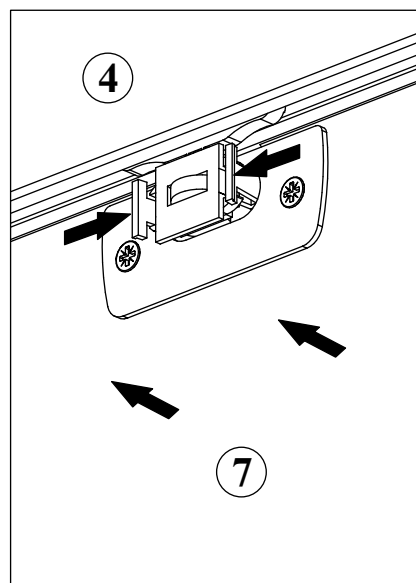
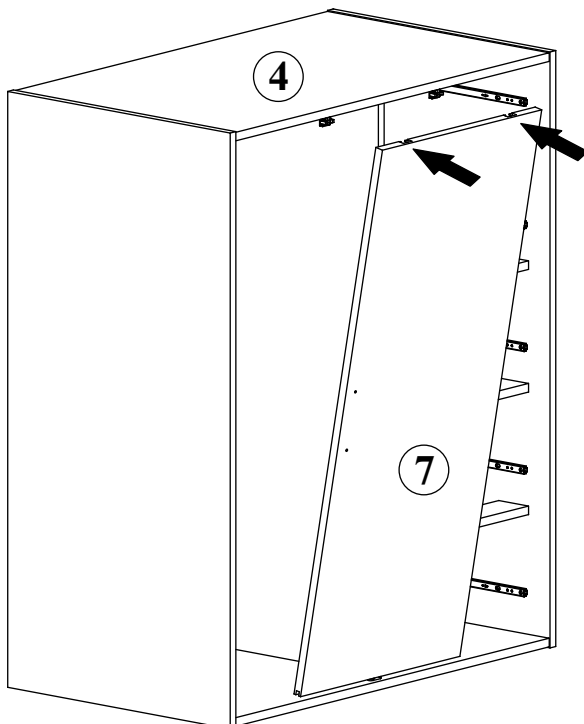
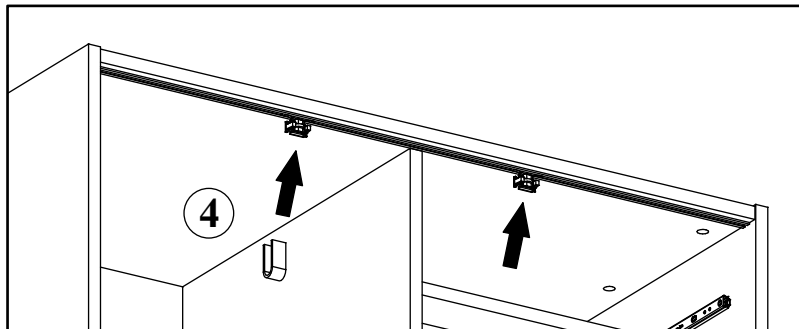

23

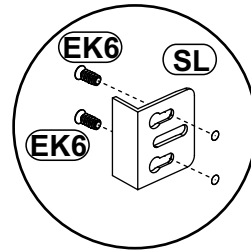
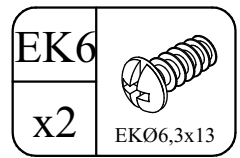
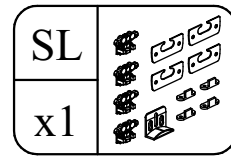
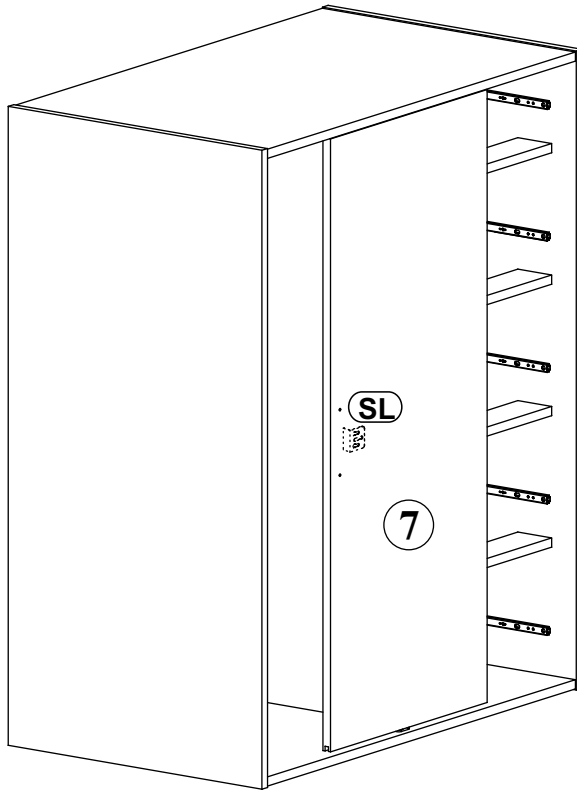

24

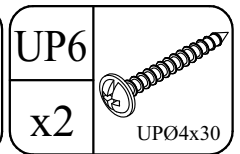
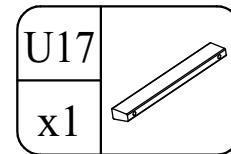
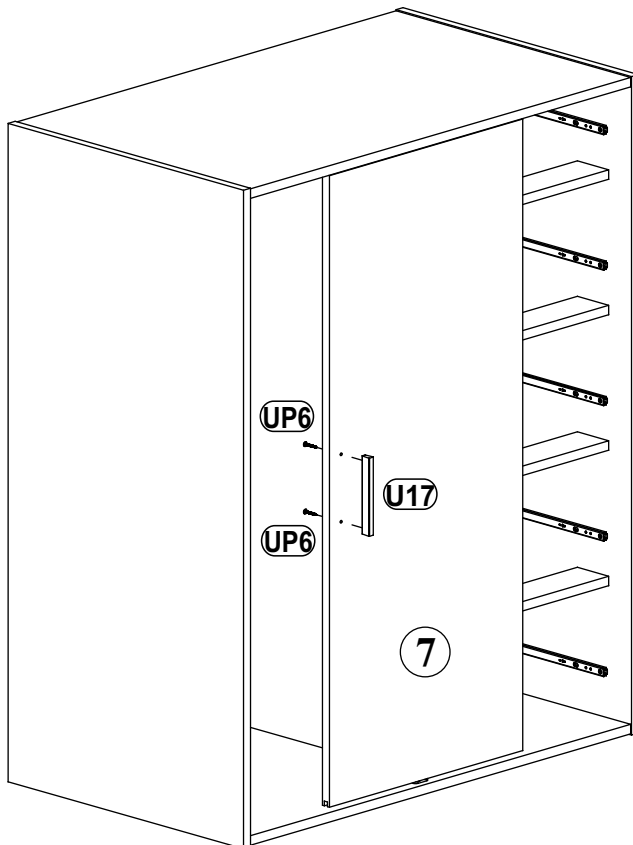

25

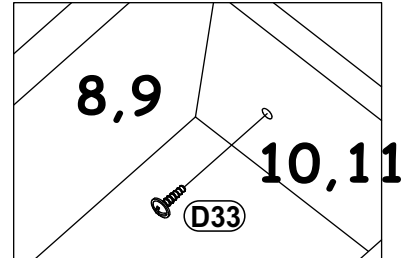
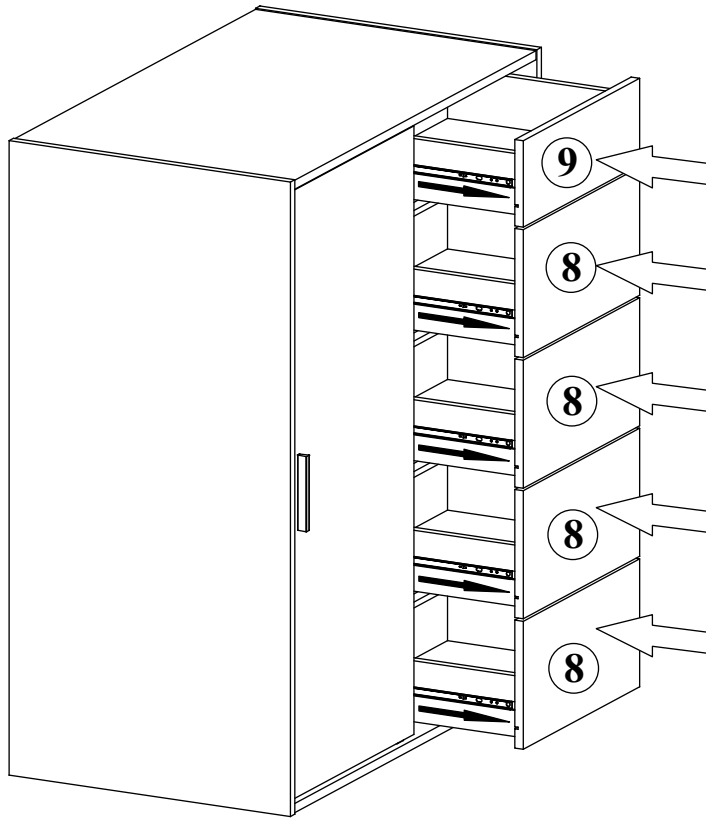
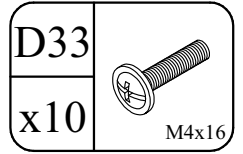

26

