

ZES/001/NML											
LED x1	A1 x3	U7 x5	W4 x10	W5 x18	F1 x14	BZB x20	P2 x13	Gt1 x6	F4 x3	E3 x5	E2 x1
L4 x1	F3 x6	W3 x6	C1 x42	C3 x24	E01 x24	E4 x2	E1 x2	I1 x1	S2 x8	Z2 x13	W9 x6
W7 x25	K1 x50	T1 x50									
M1 x50	W1 X26										

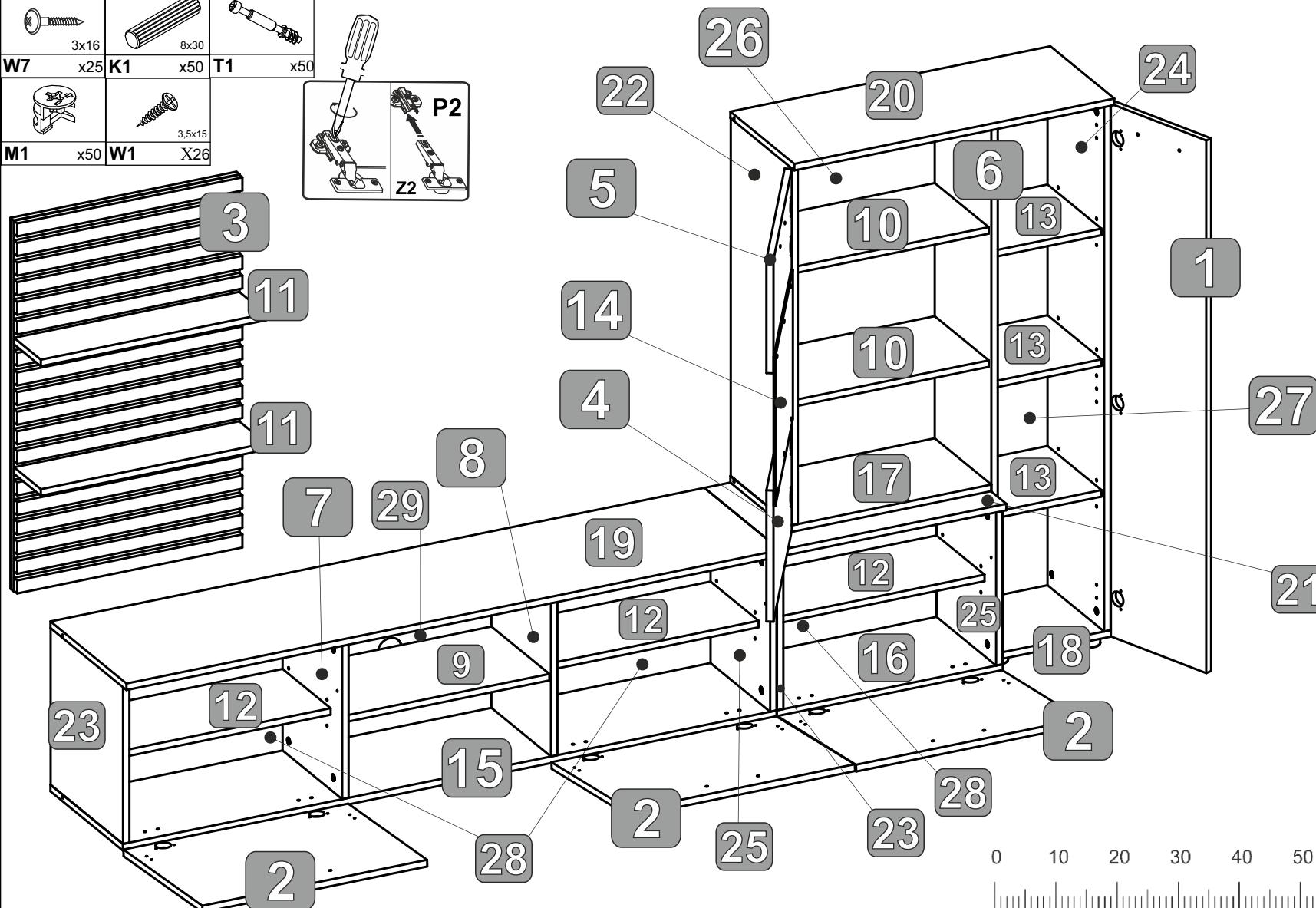

1	1304	293	16	1
2	562	395	16	3
3	908	565	32	1
4	500	321	16	1
5	500	278	16	1
6	1292	283	16	1
7	384	298	16	1
8	384	298	16	1
9	506	290	16	1
10	484	270	16	2
11	563	134	16	2
12	532	240	16	3
13	266	270	16	3
14	478	365	4	1
15	1635	362	16	1
16	565	362	16	1
17	501	303	16	1
18	300	303	16	1
19	1635	380	16	1
20	800	320	16	1
21	565	380	16	1
22	876	303	16	1
23	384	362	16	2
24	1292	303	16	1
25	384	362	16	2
26	891	500	3	1
27	1307	281	3	1
28	547	399	3	3
29	520	399	3	1



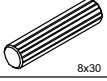
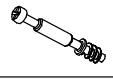

1

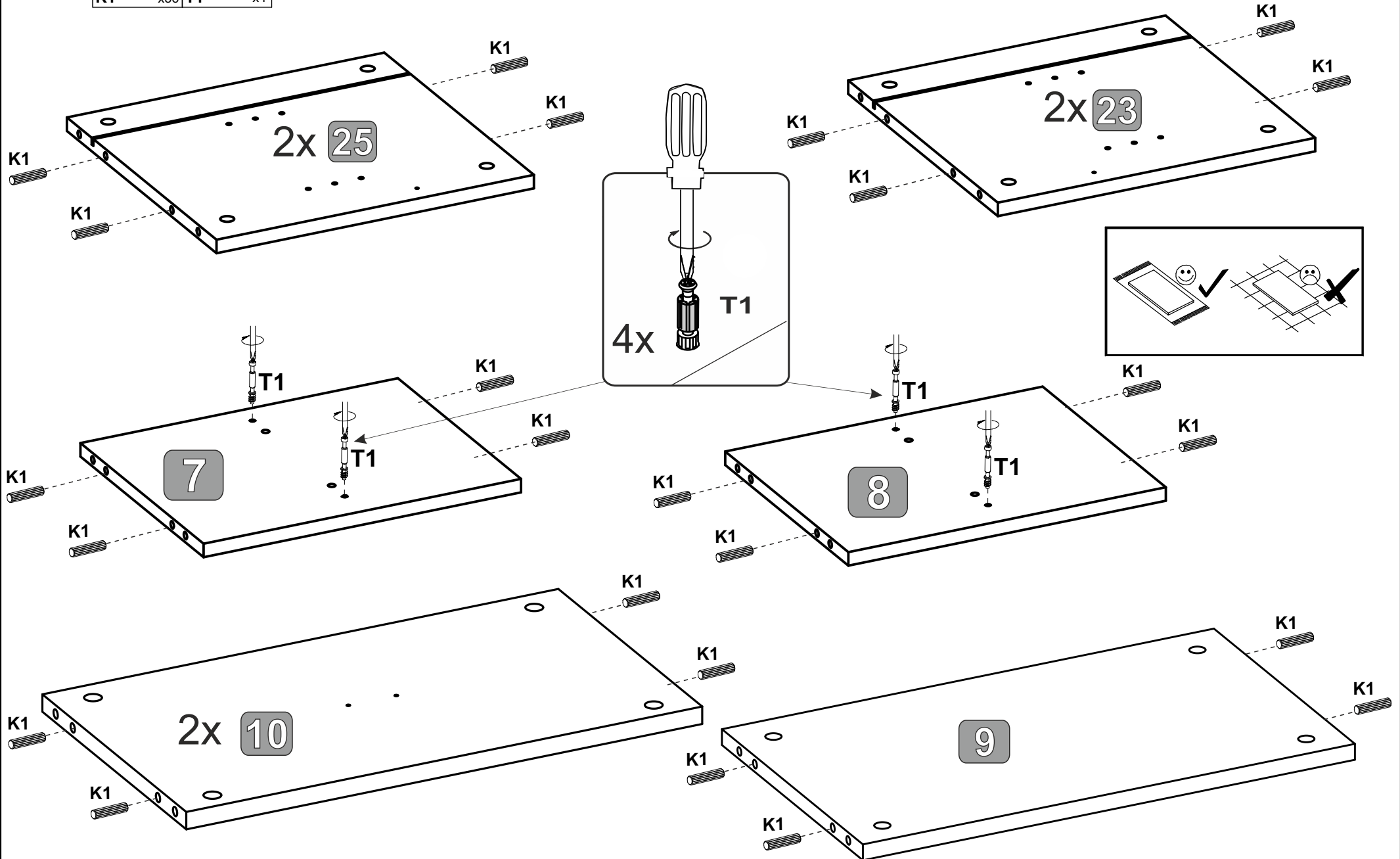
	8x30		
K1	x36	T1	x4





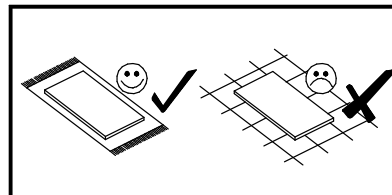
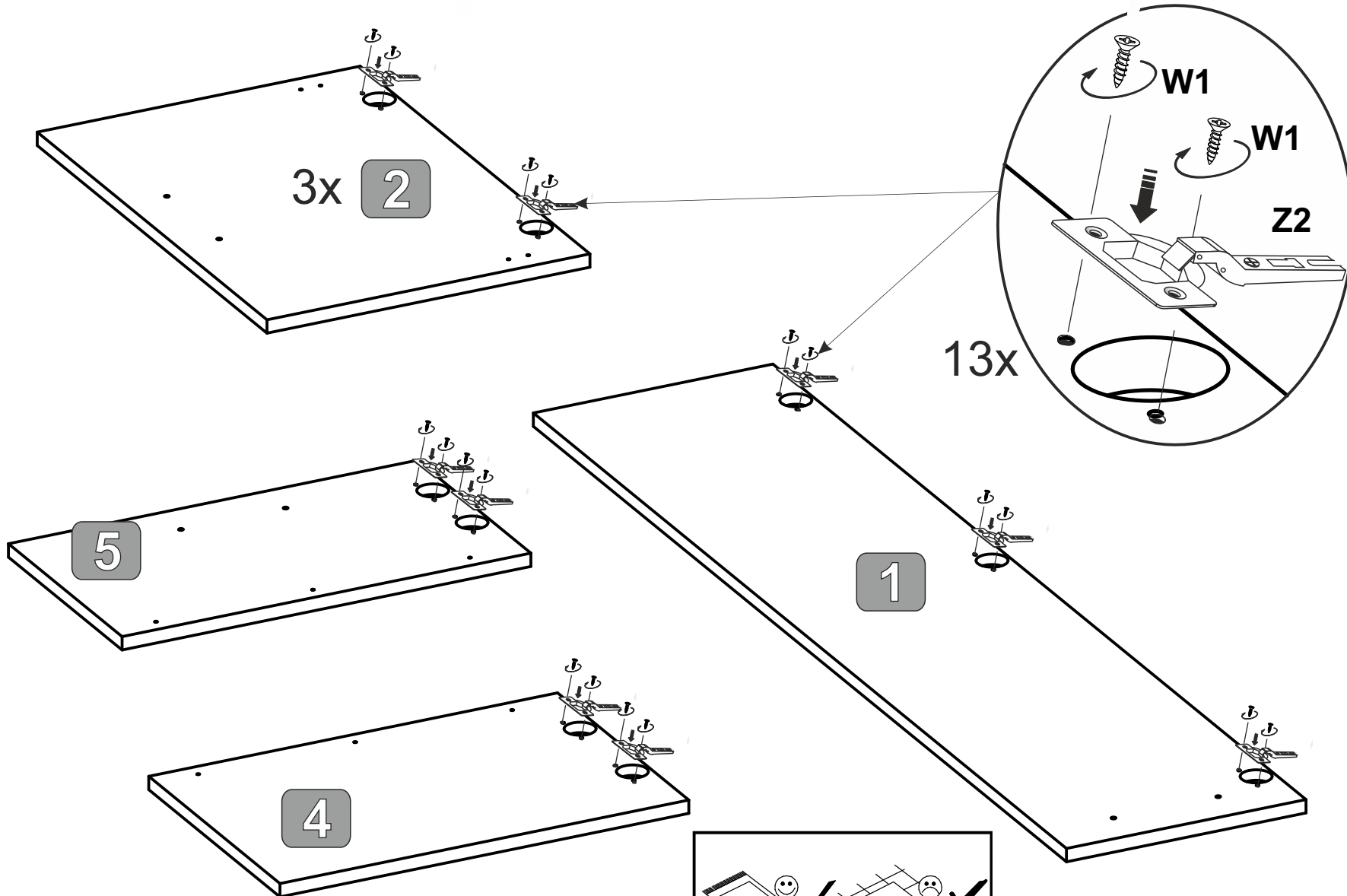

2

	
Z2	3,5x15
x13	W1 X26



3

			
W5	F1	T1	P2
x14	x14	x16	x6

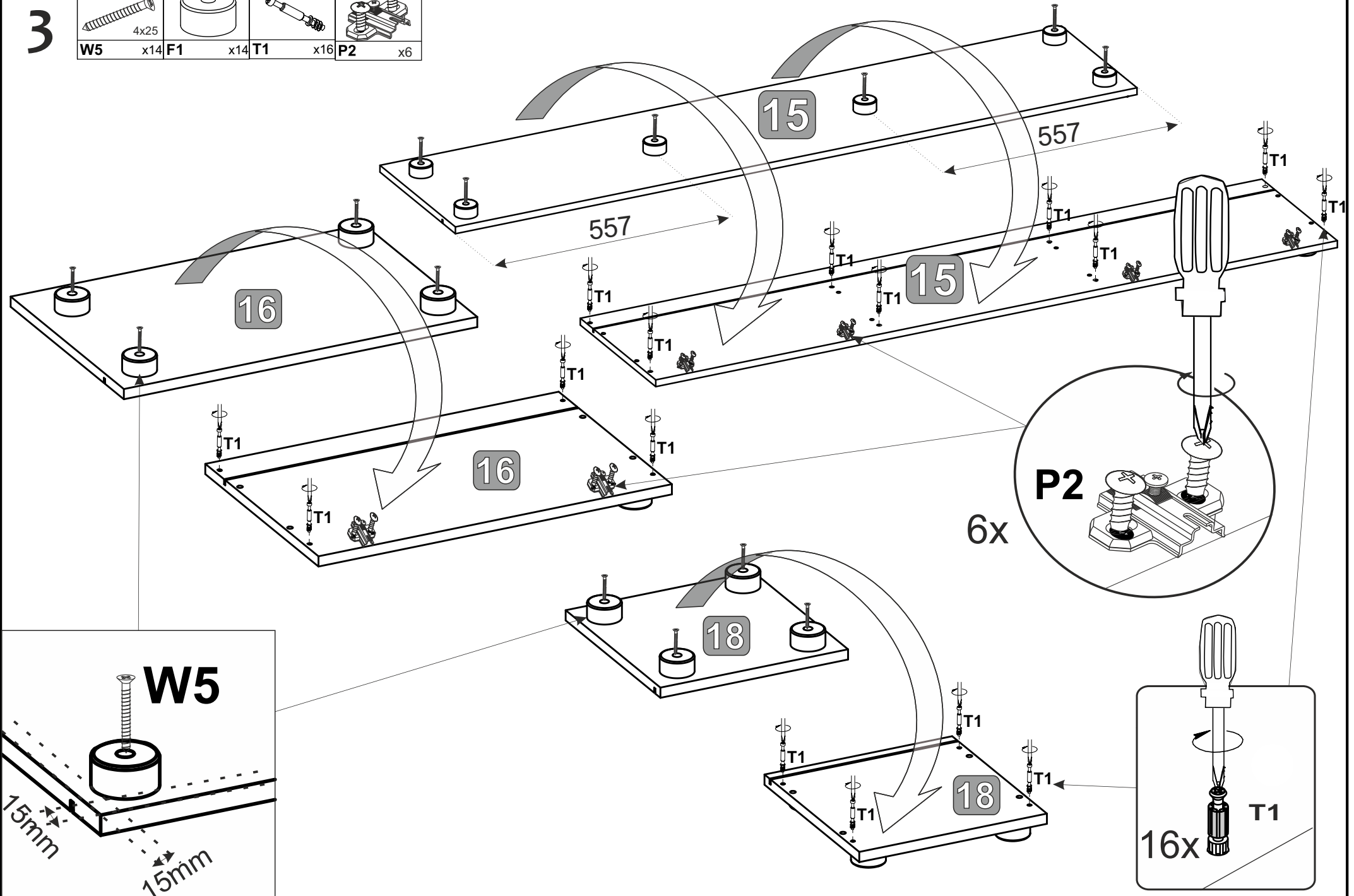

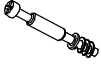
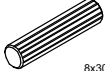

4

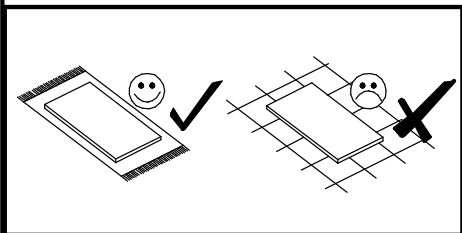
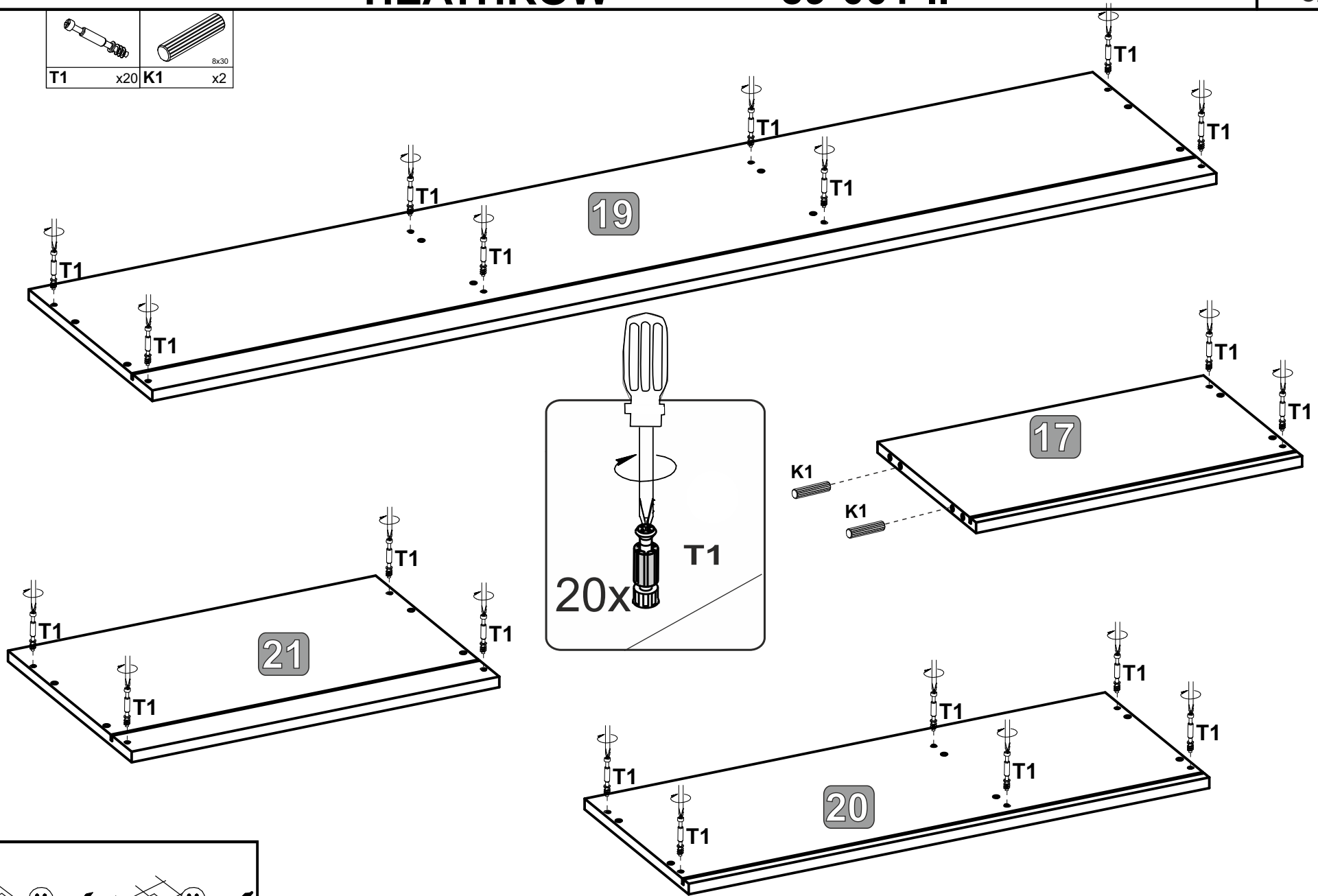
	
T1	8x30
x20	K1
	x2

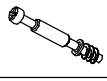
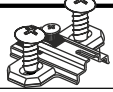
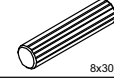
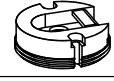

5

									
T1	x10	P2	x7	K1	x12	A1	x3	W9	x6

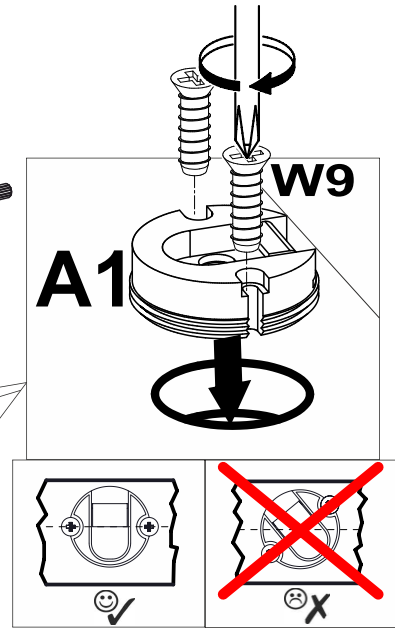
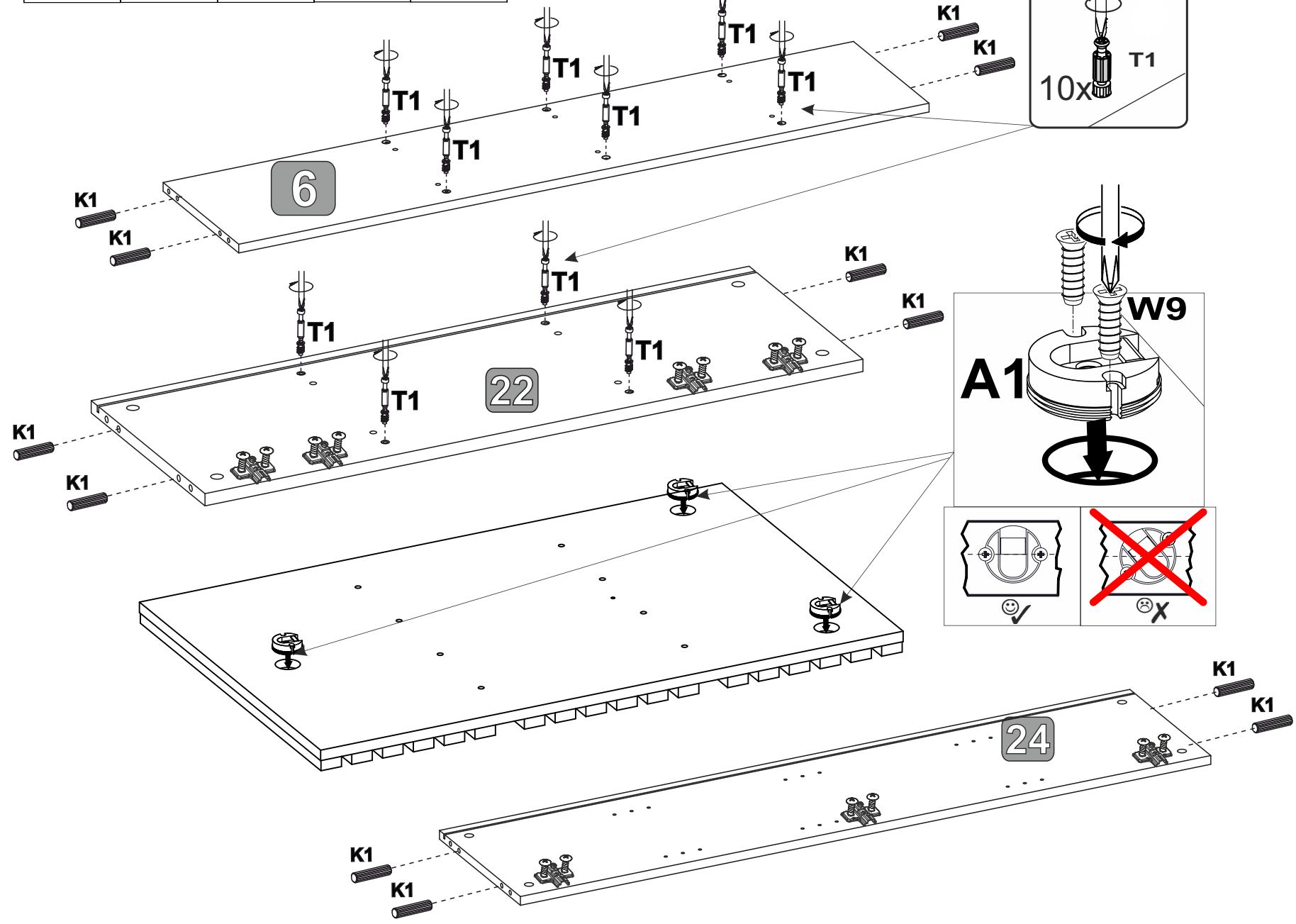
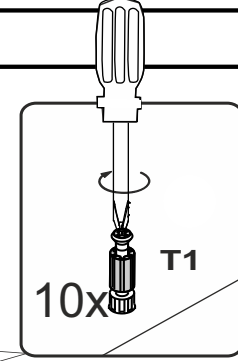

6

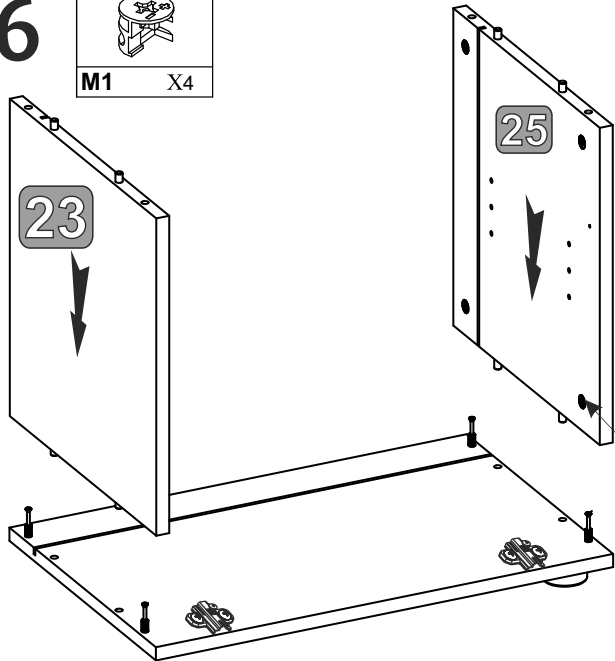
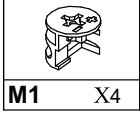

4x

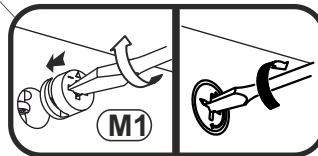

7

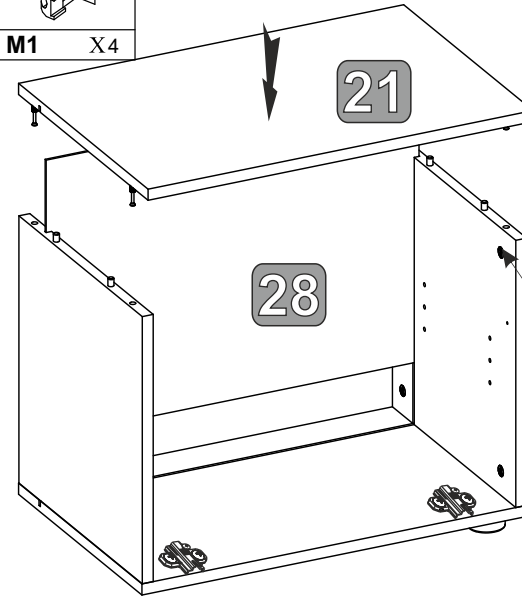

4x

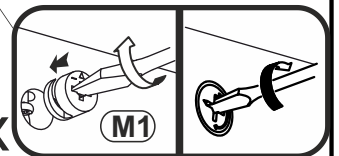

8

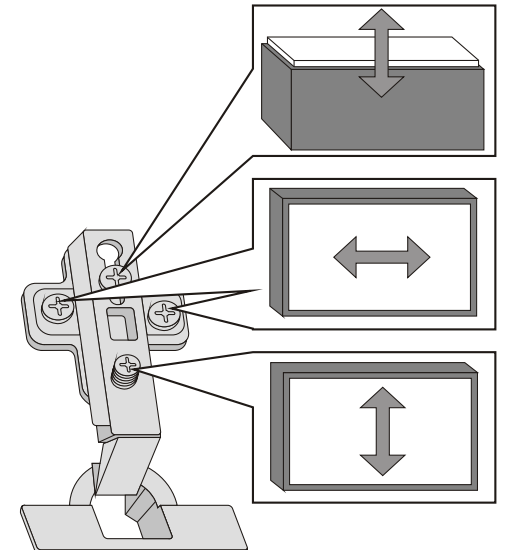
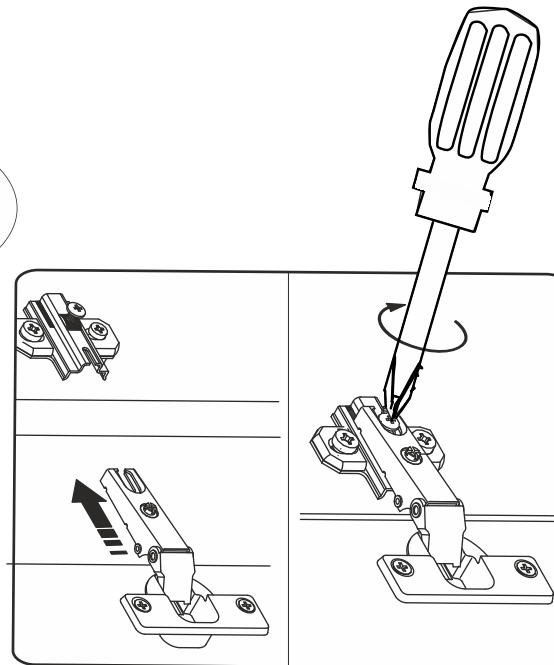
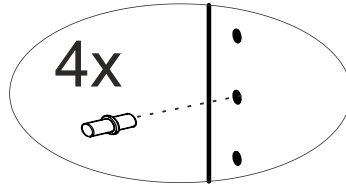
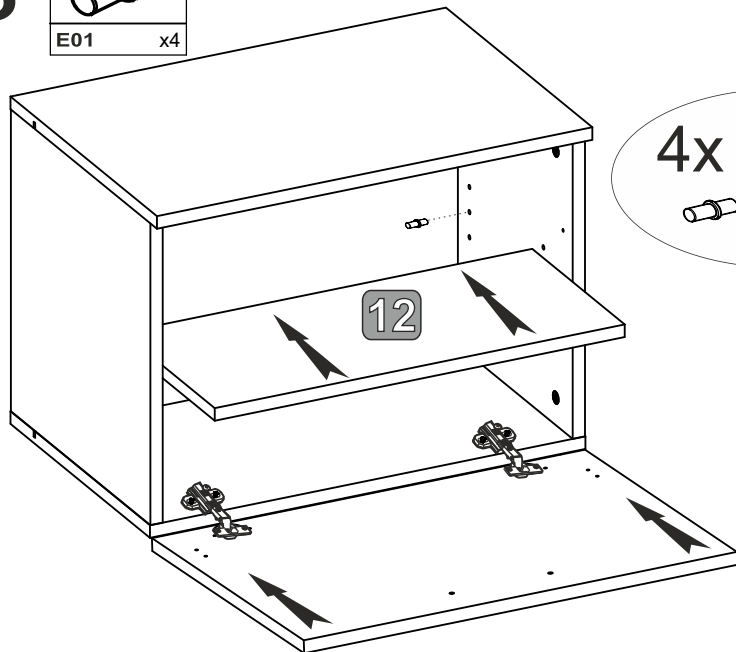
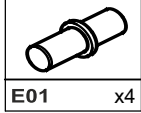

9

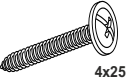
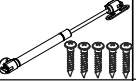
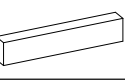
					
4x25					
W4	x2	Gt1	x2	U7	x1

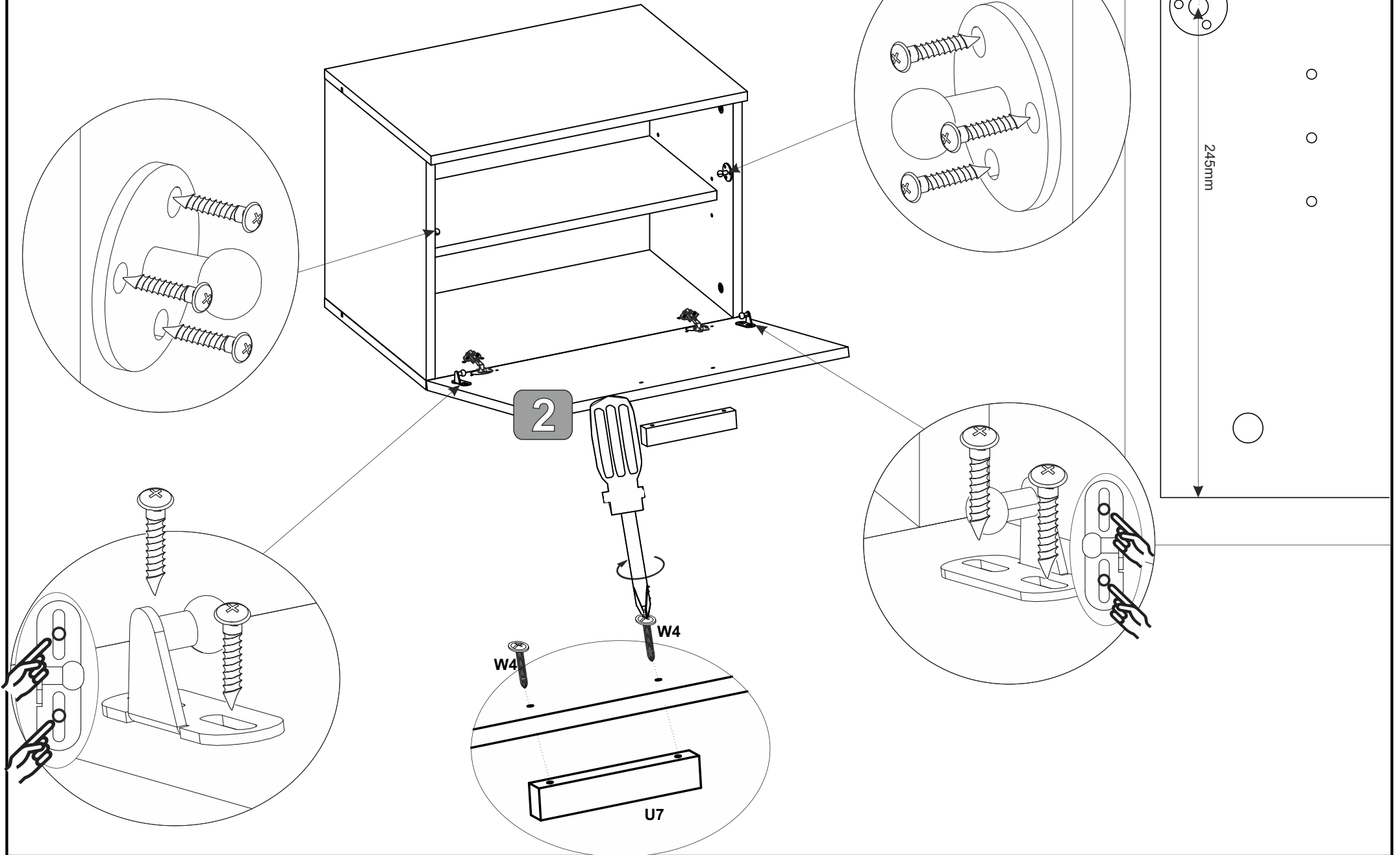

26mm

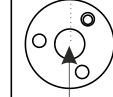

245mm

2

W4

W4

U7

10

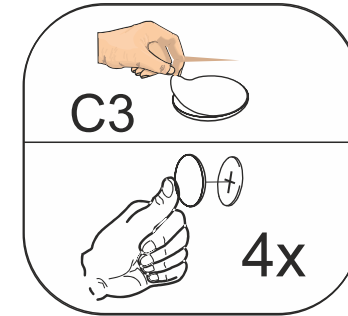
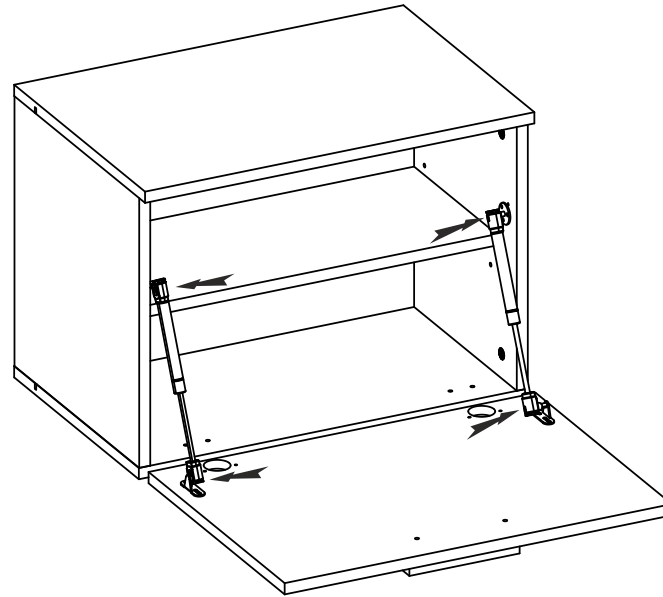
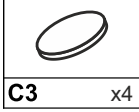

11

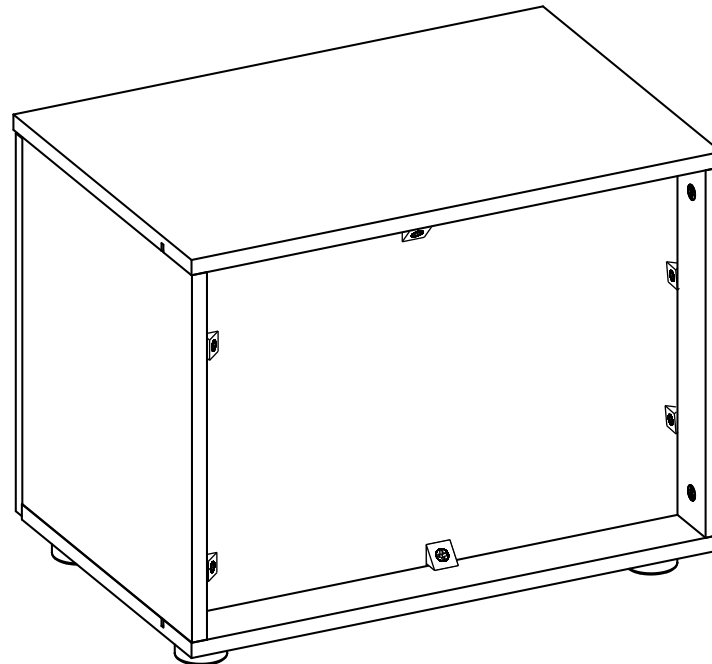
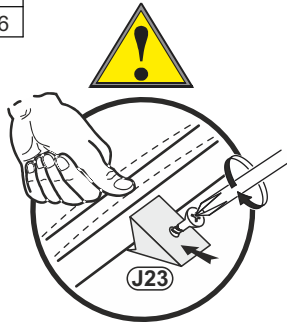
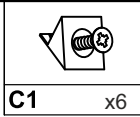

a=b

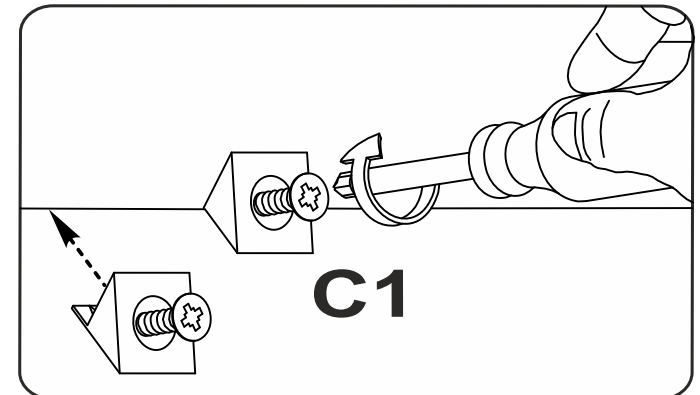
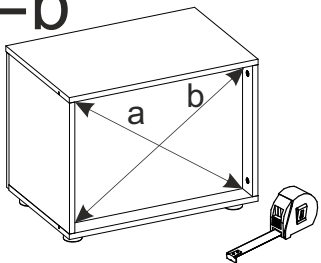

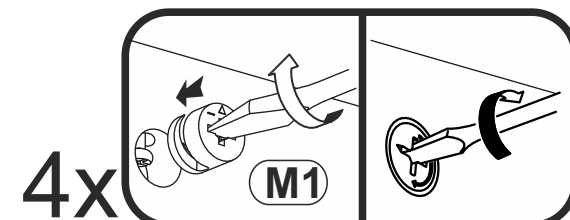
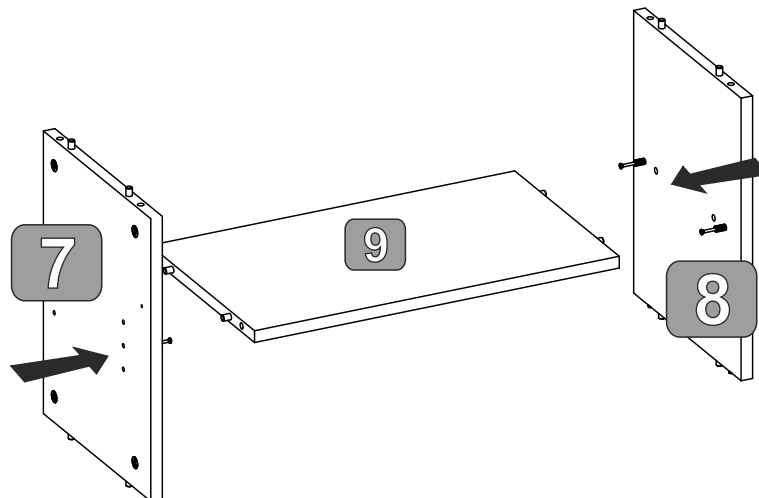
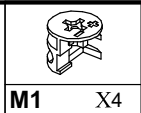

12

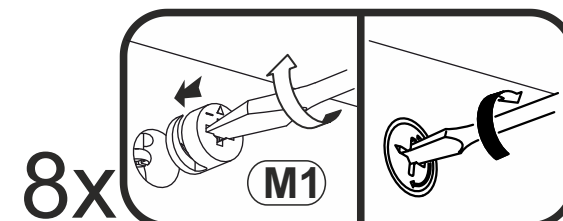
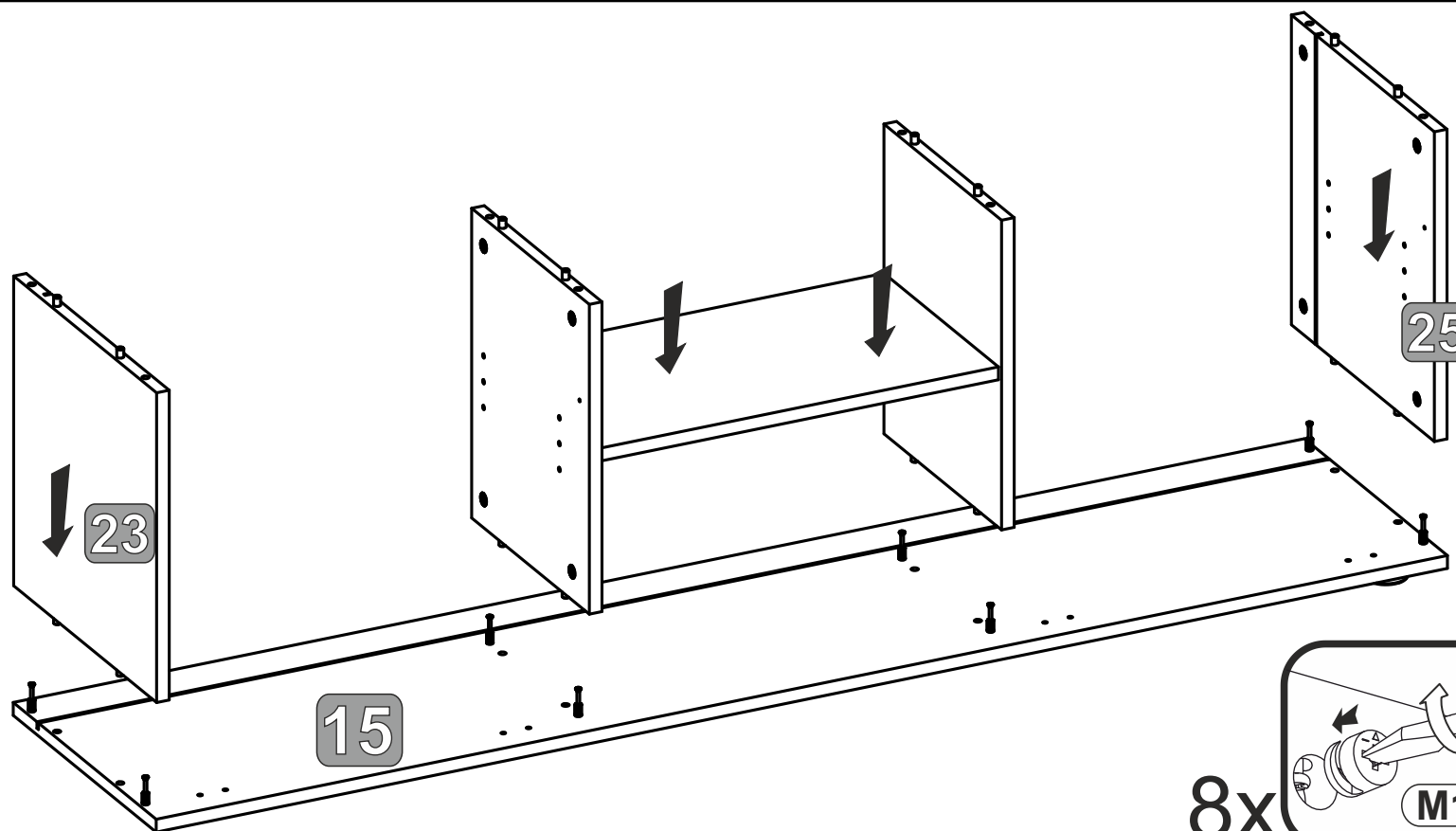
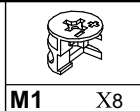

13



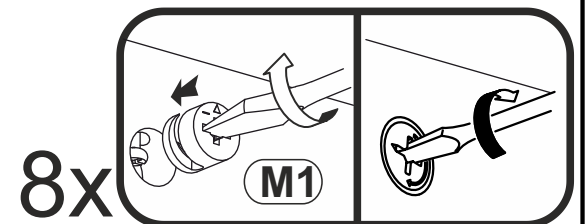
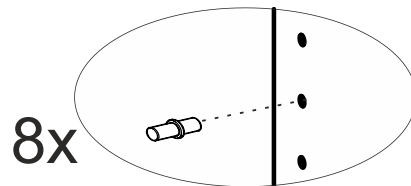
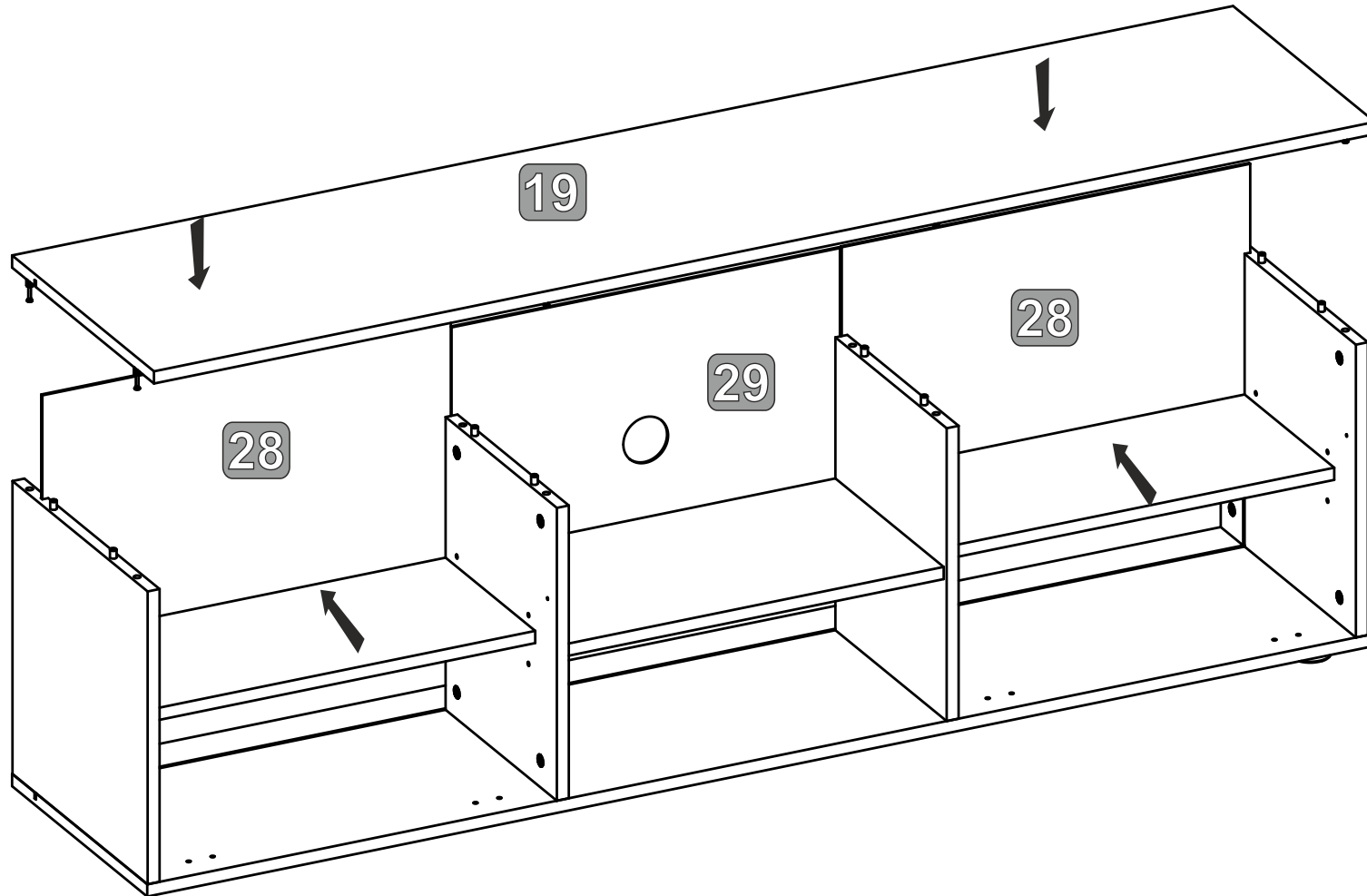

14

	
M1 X8	E01 x8



15

		
C1	W7	BZB
x16	x10	x10

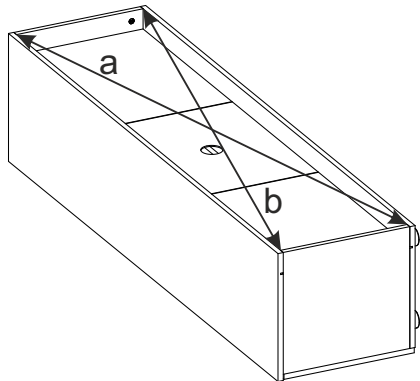
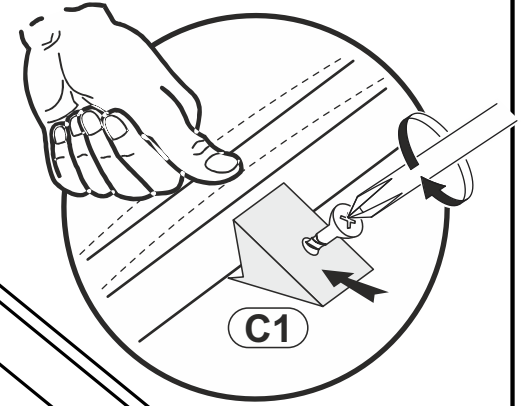
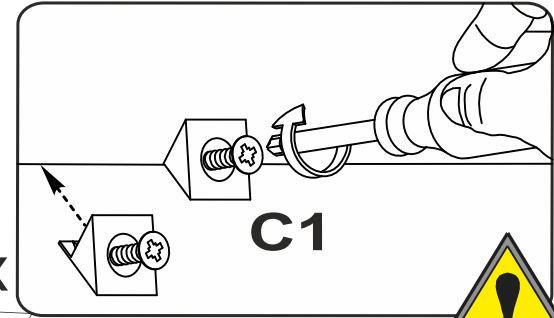
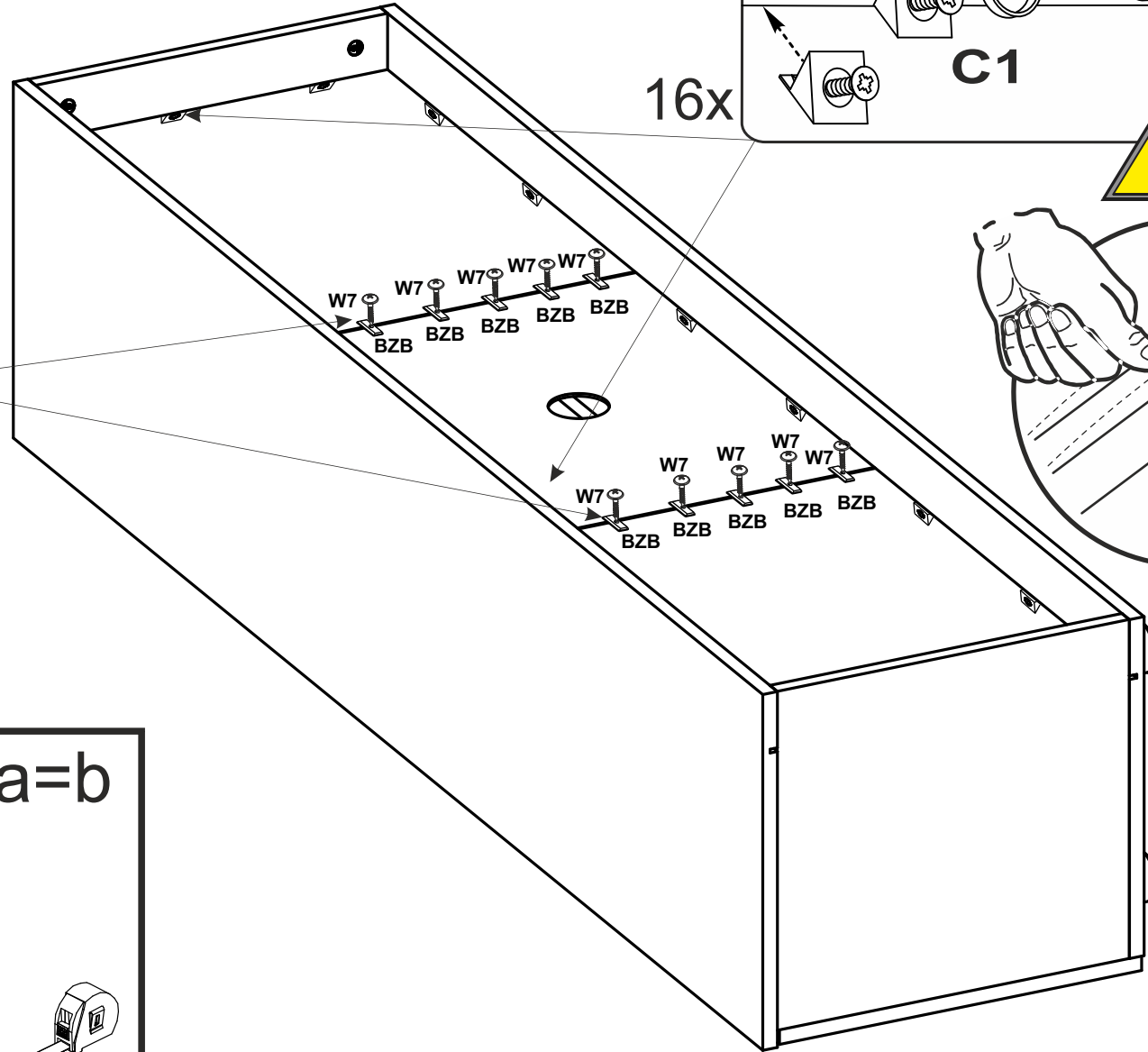
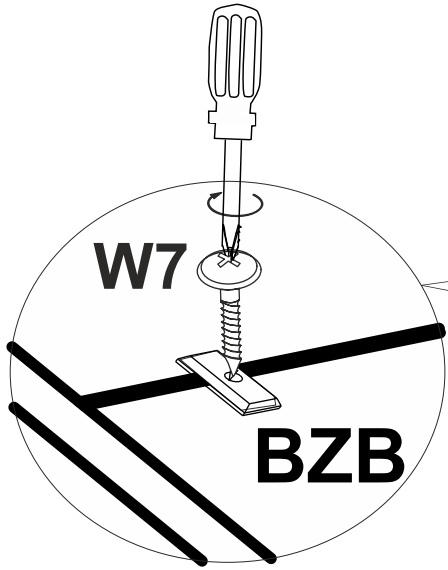

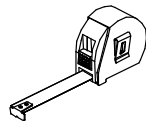

a=b

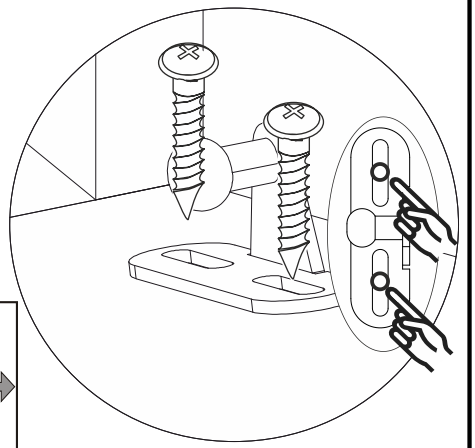
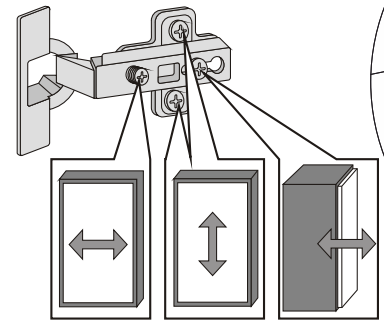
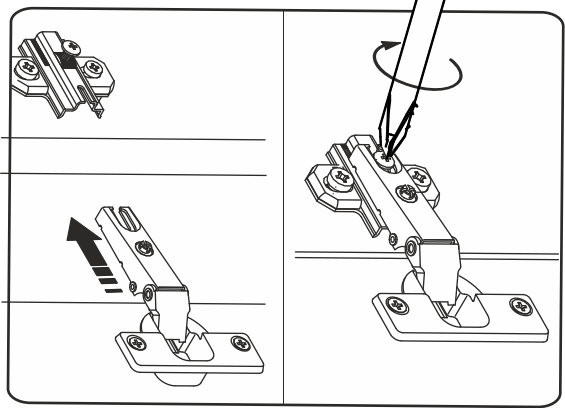
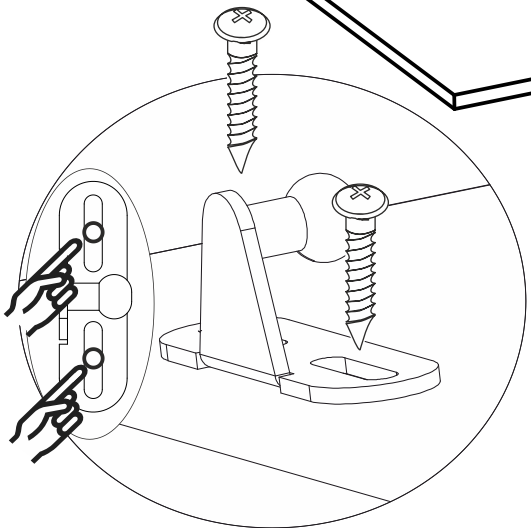
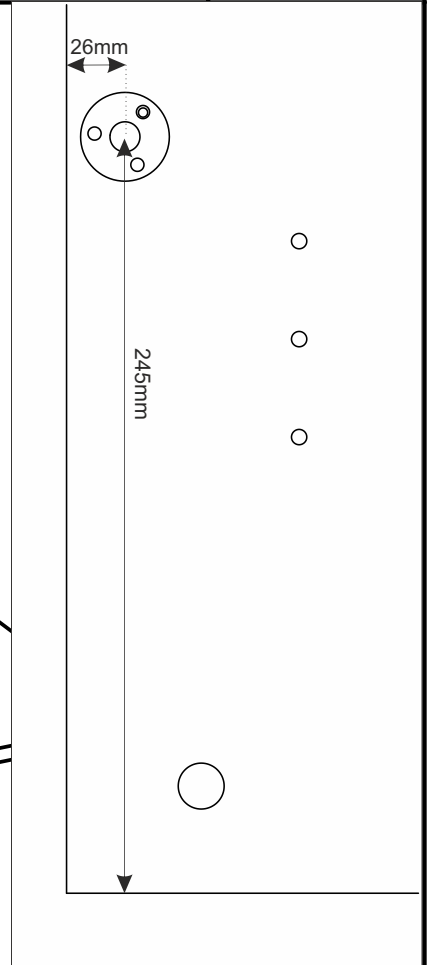
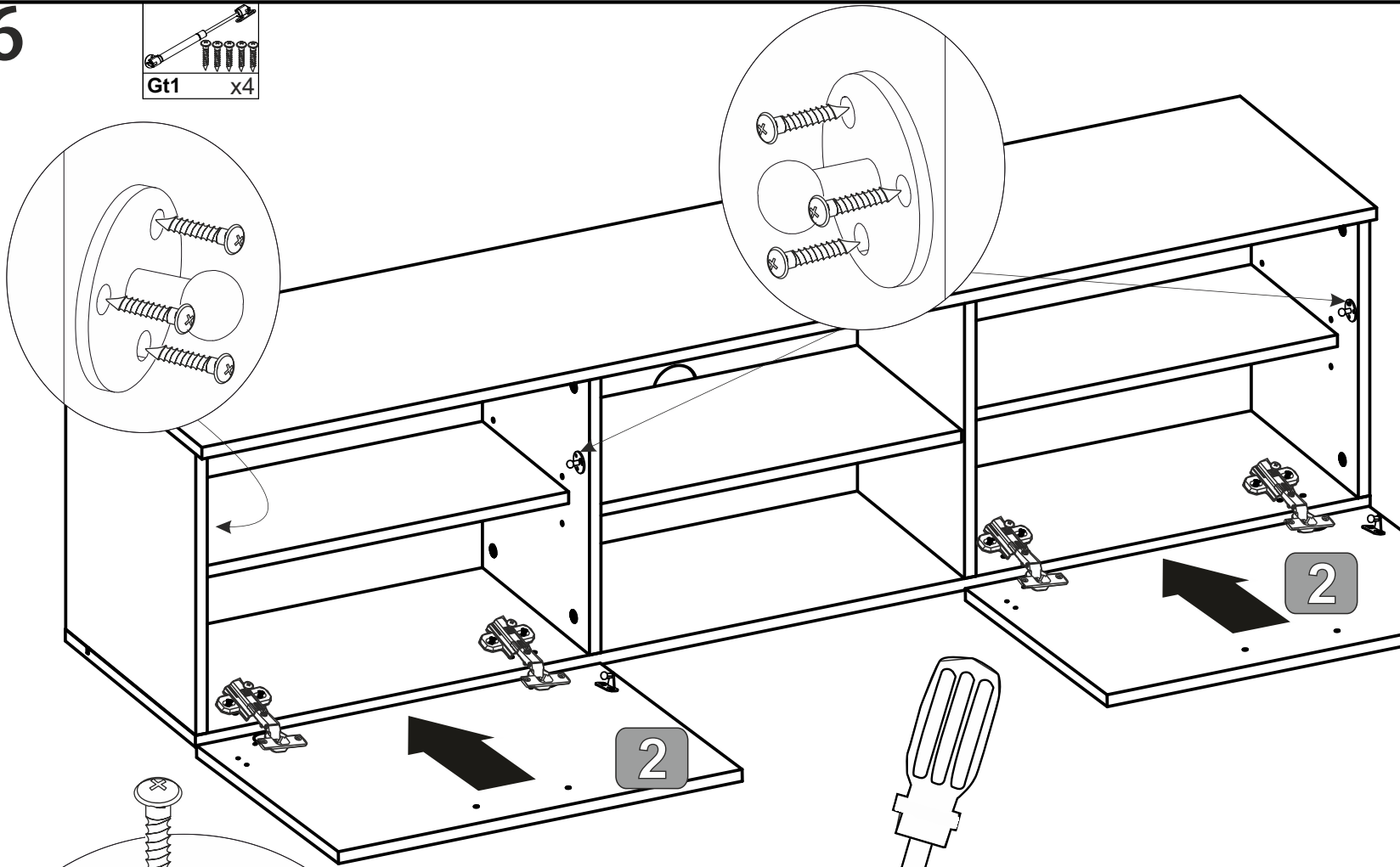
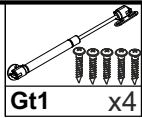

16

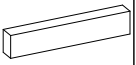

17

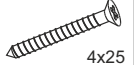
					
U7	x2	W4	x4	W5	x4

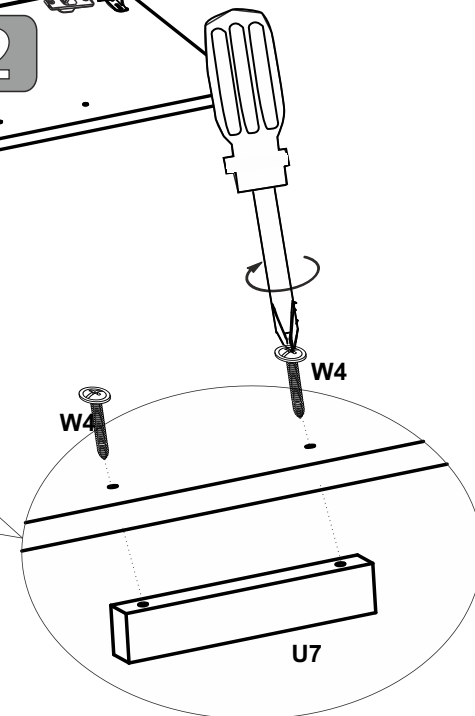
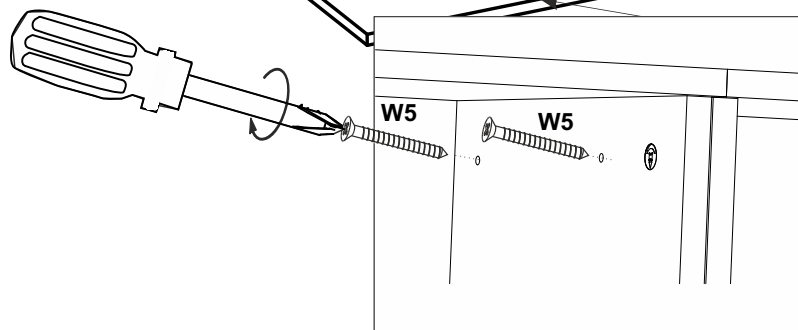
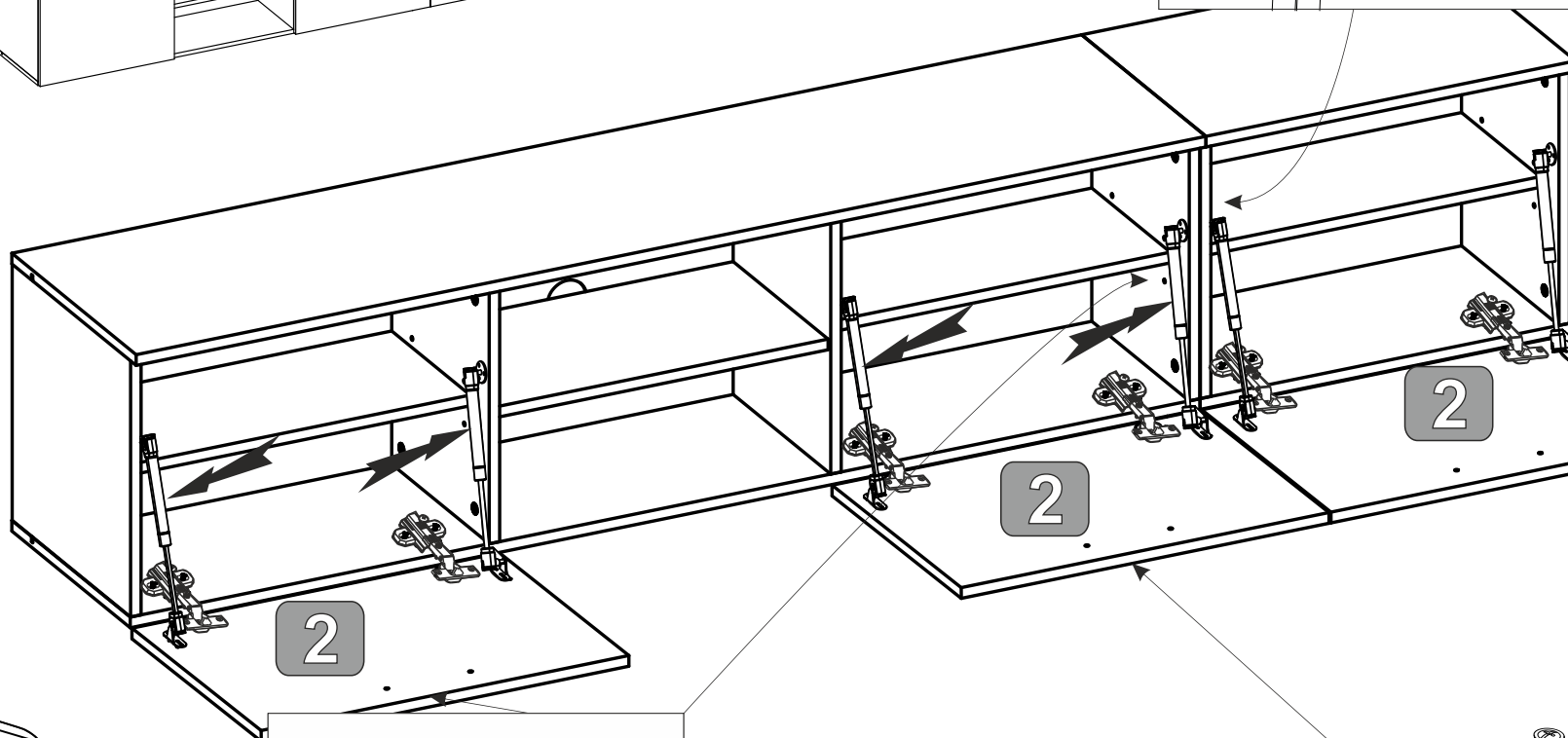
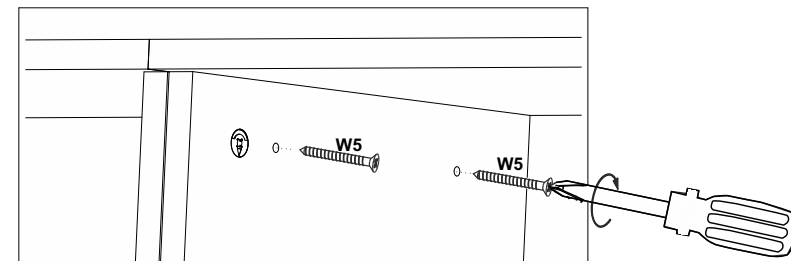
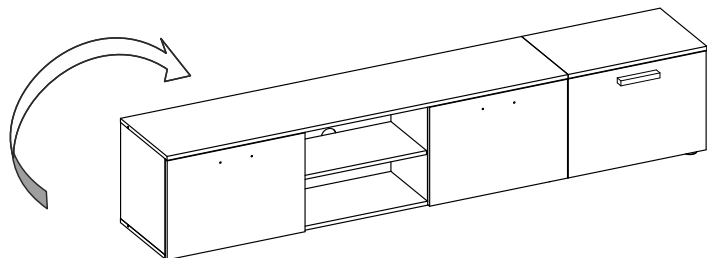

18

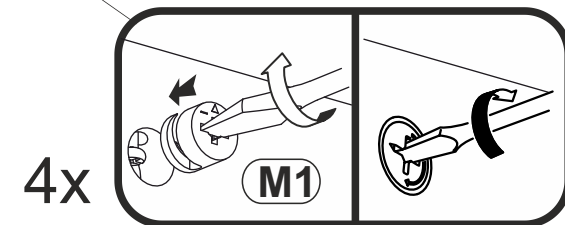
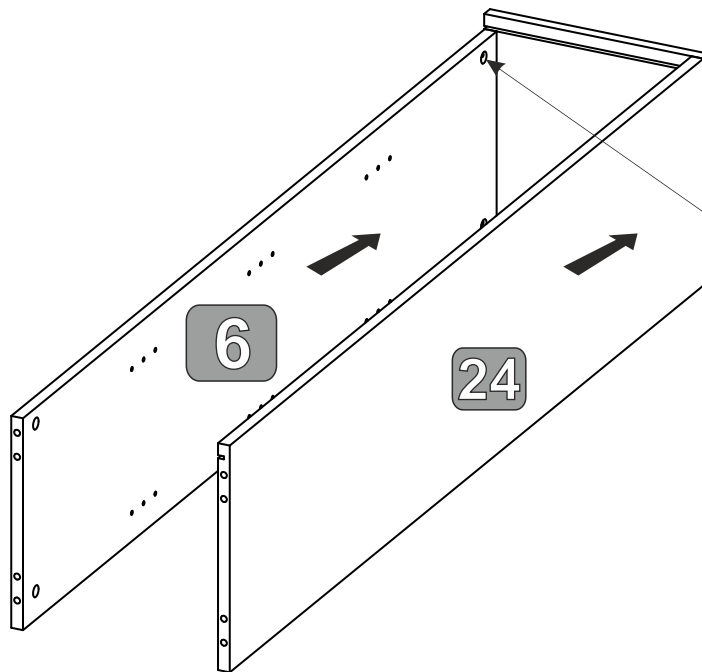
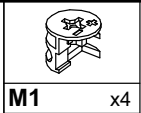

19

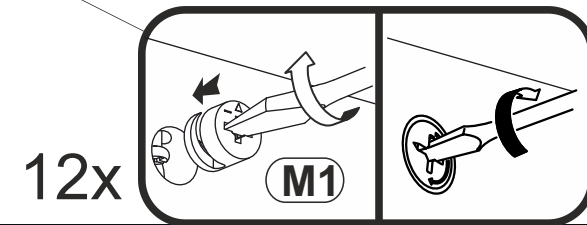
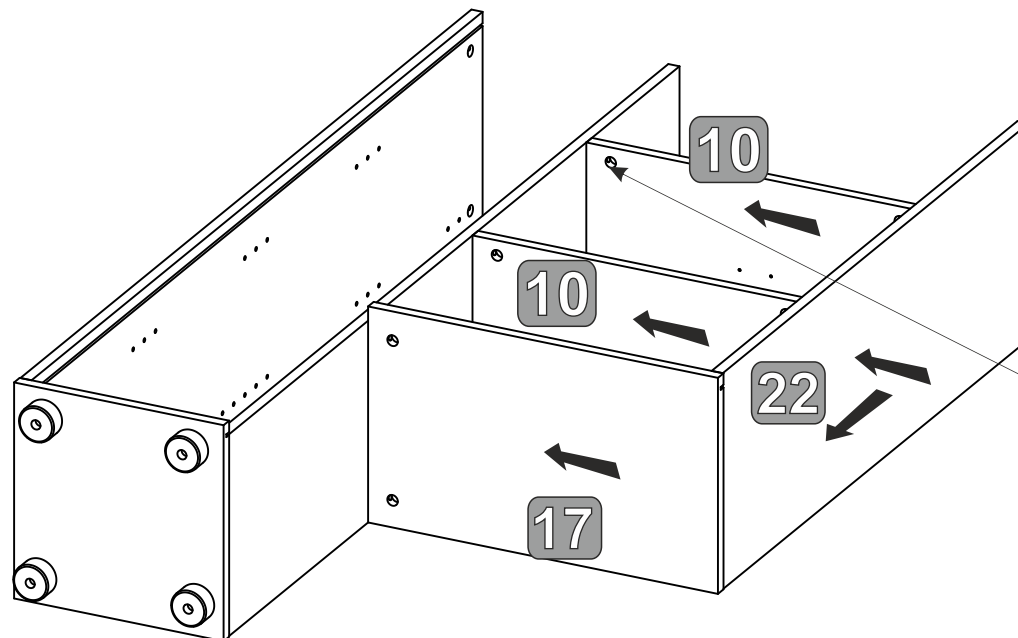
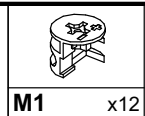

20

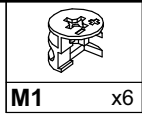

M1 x6

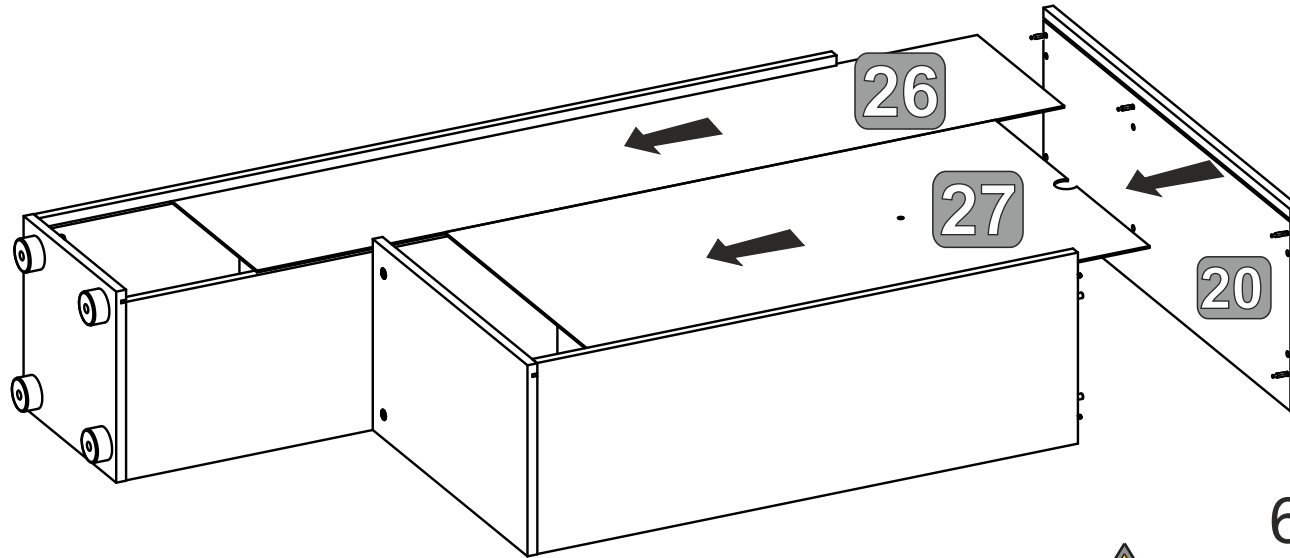

6x

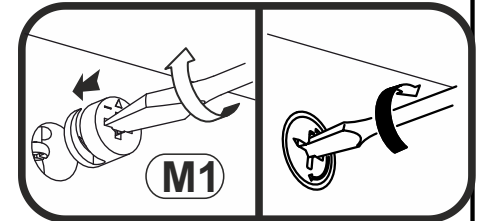

21

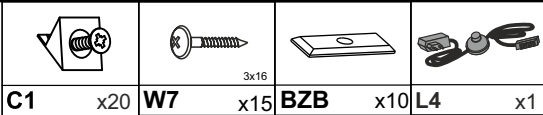

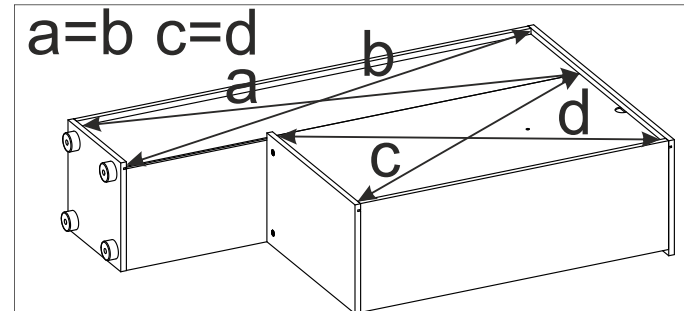
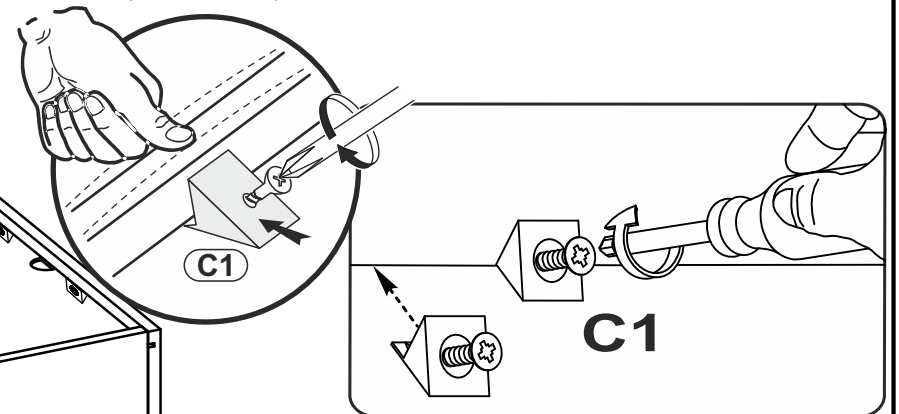
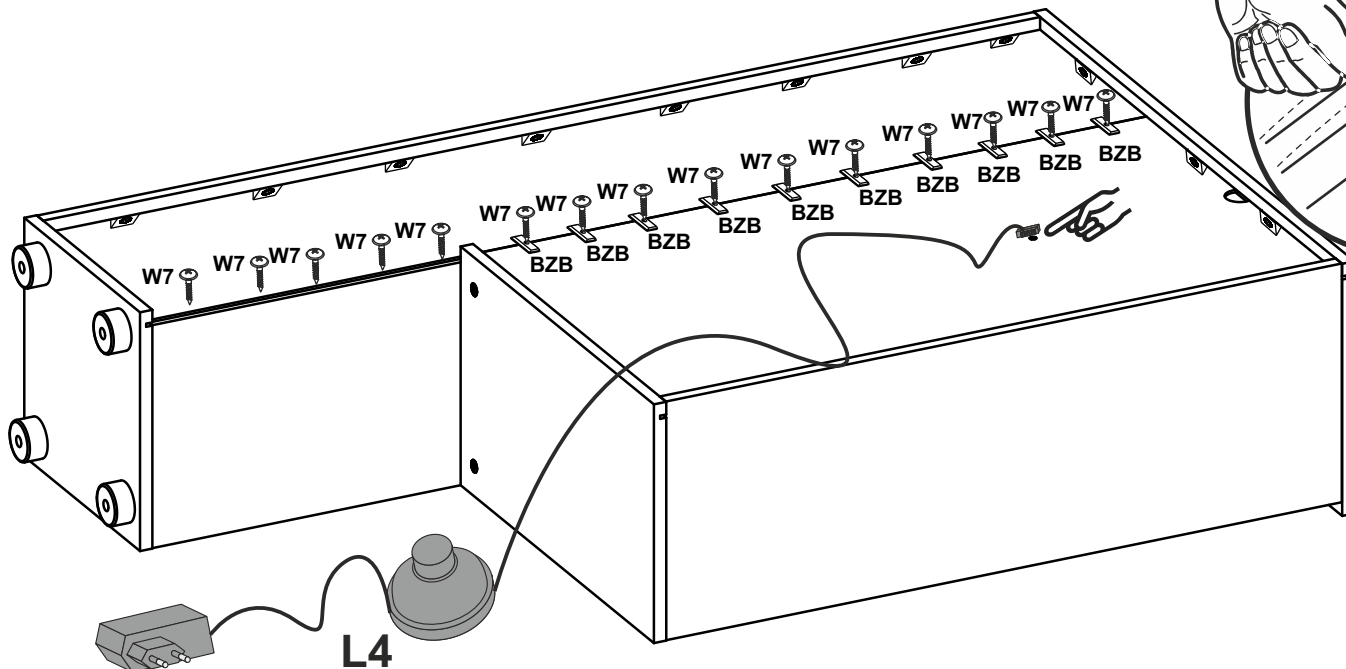

C1 x20 W7 x15 BZB x10 L4 x1





a=b c=d

22

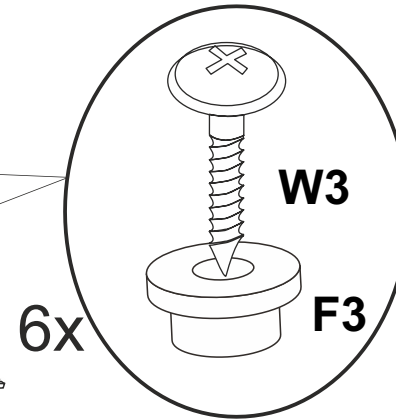
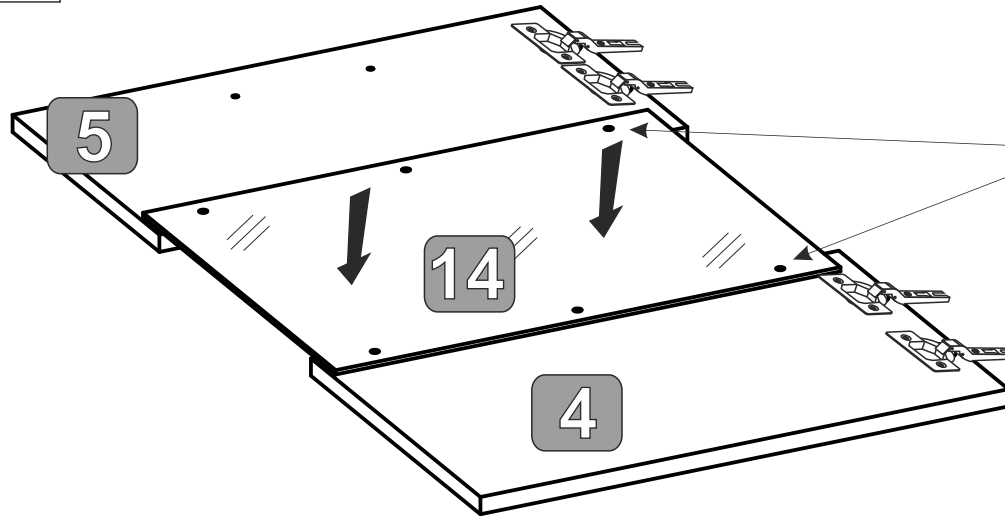
	3,5x16
	
F3 x6	W3 x6





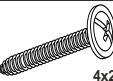

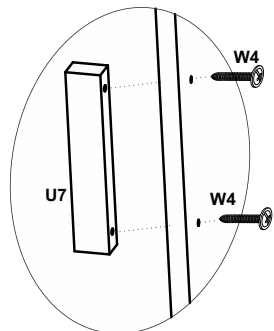
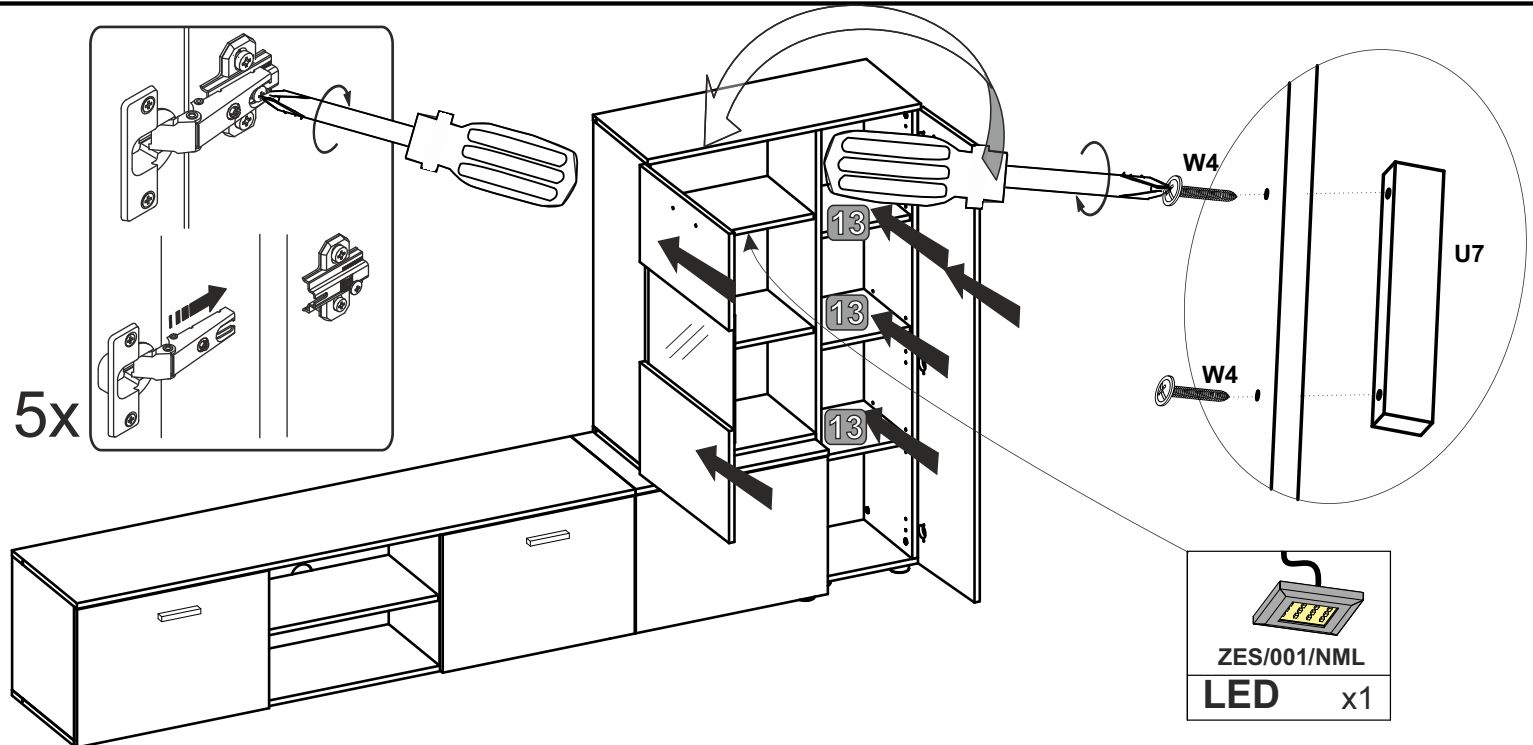
23

	
ZES/001/NML LED x1	E01 x12
	
U7 x2	W4 4x25 x4





ZES/001/NML LED x1

24

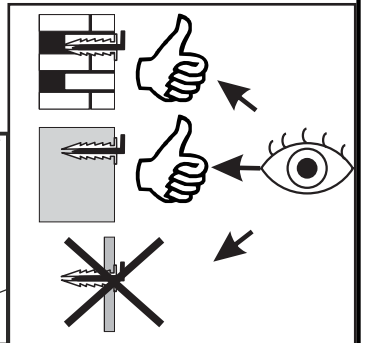
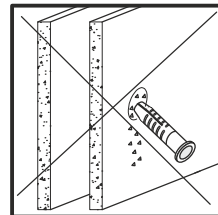
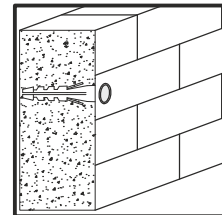
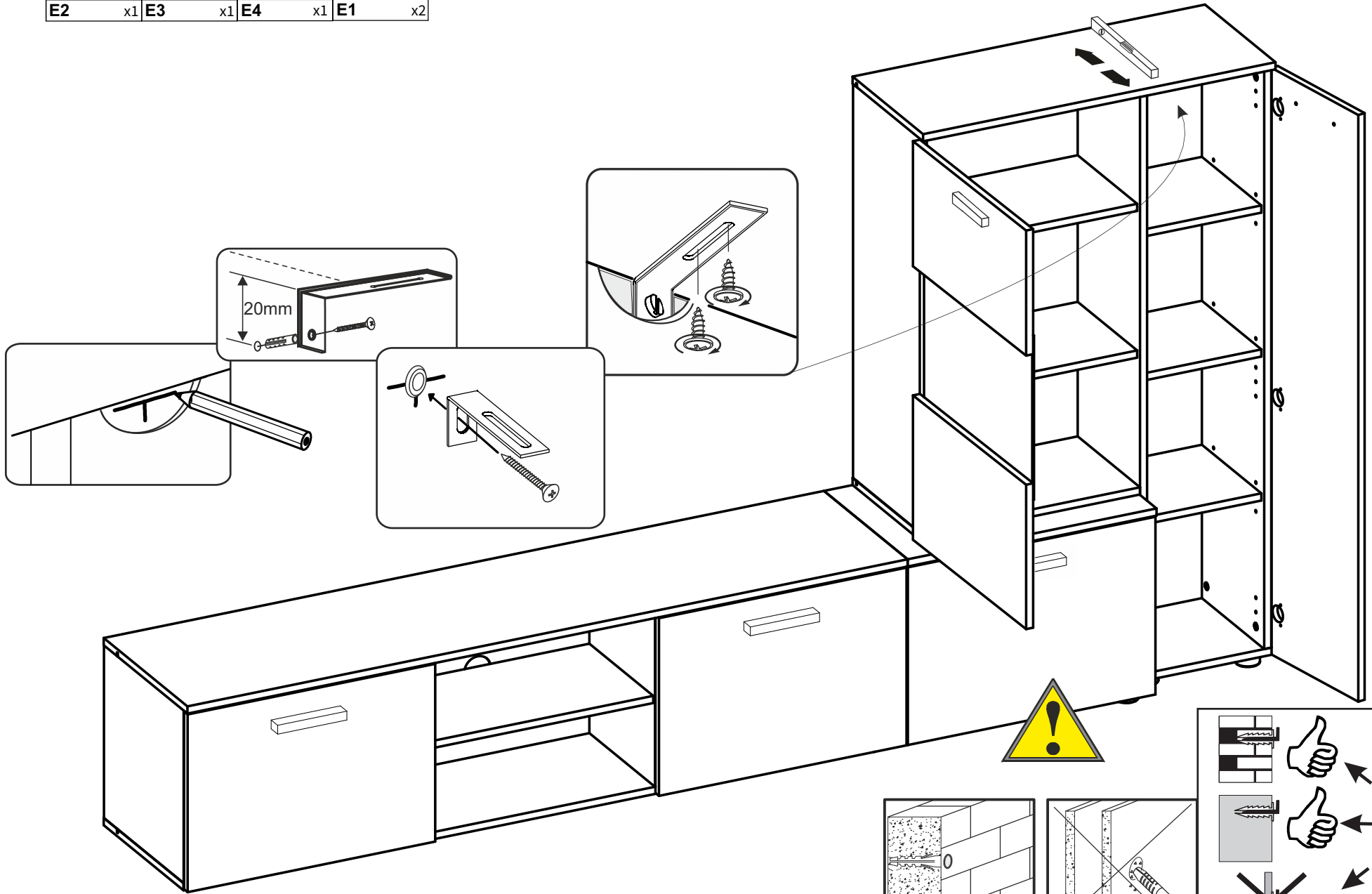
			
E2	x1	E3	x1
E4	x1	E1	x2

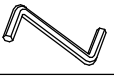

25

	
I1 x1	S2 x8

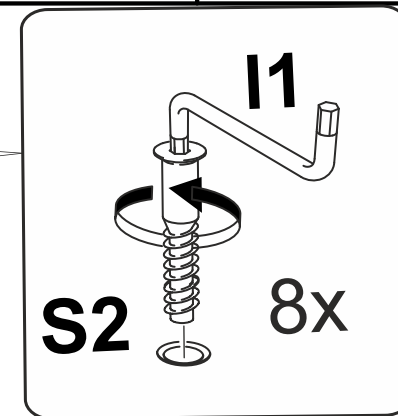
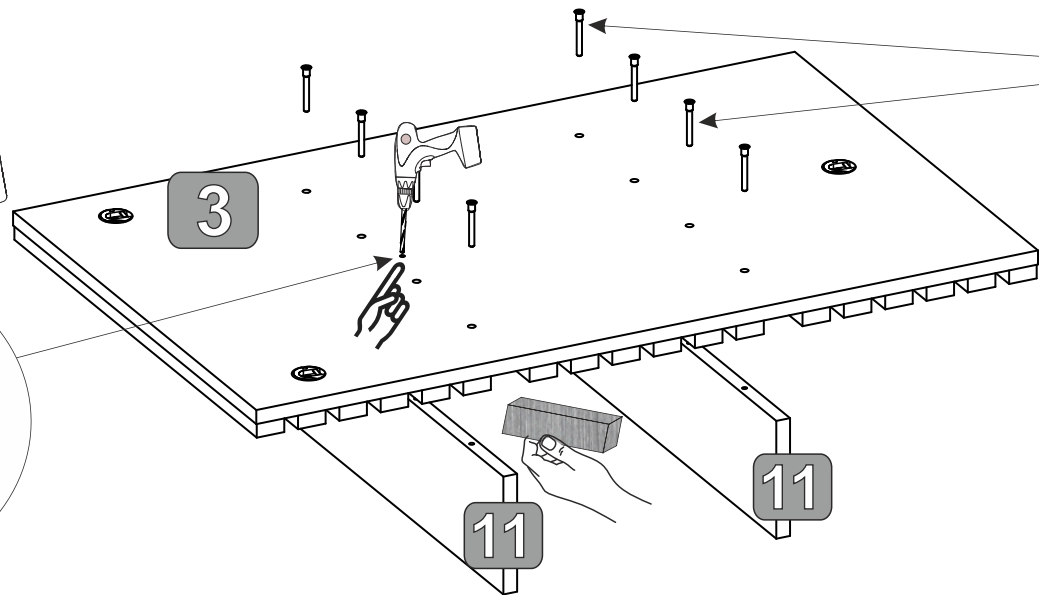
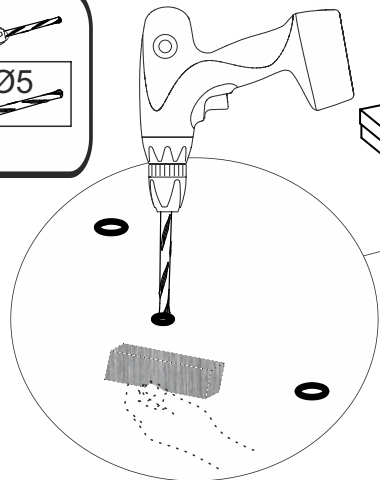
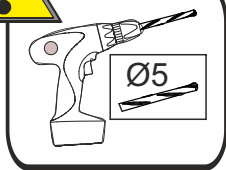

26

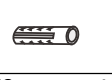
	
F4 x3	E3 x4

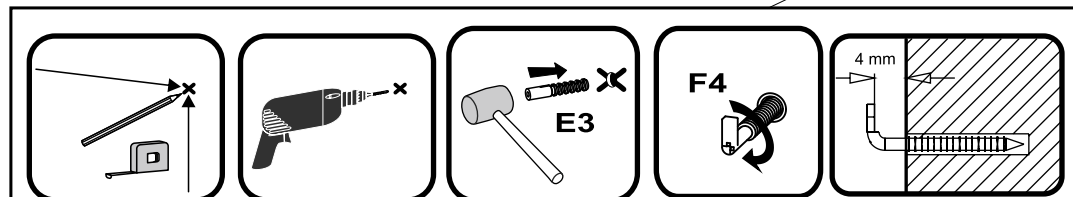
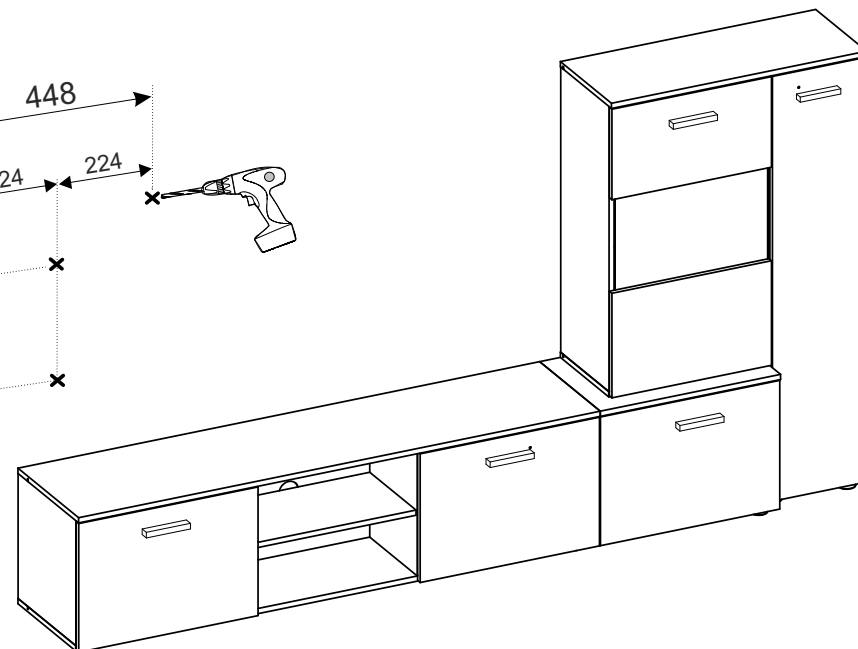
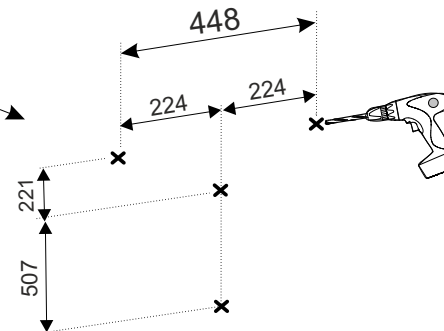
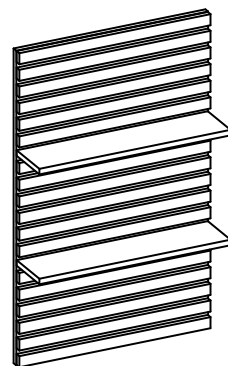

27

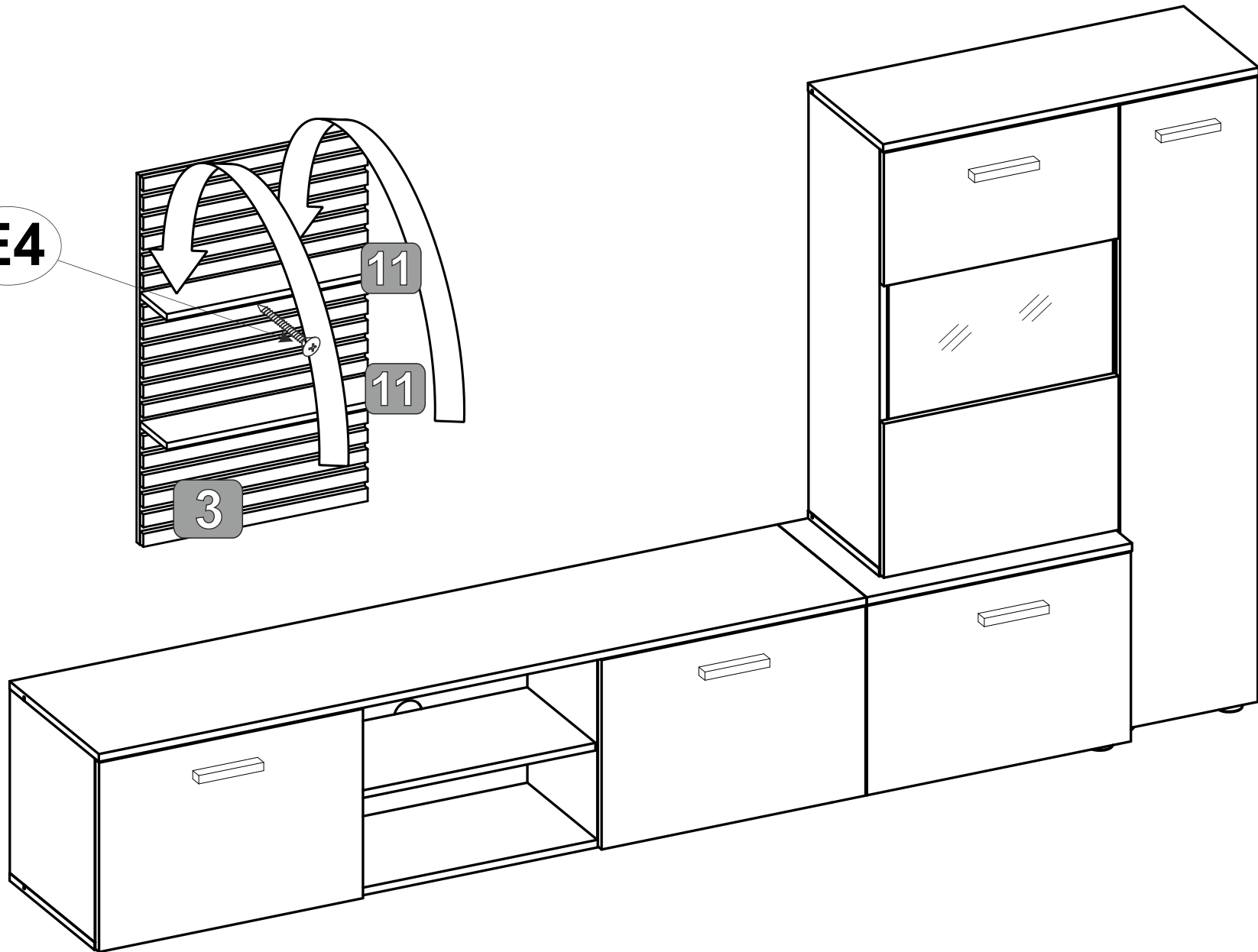
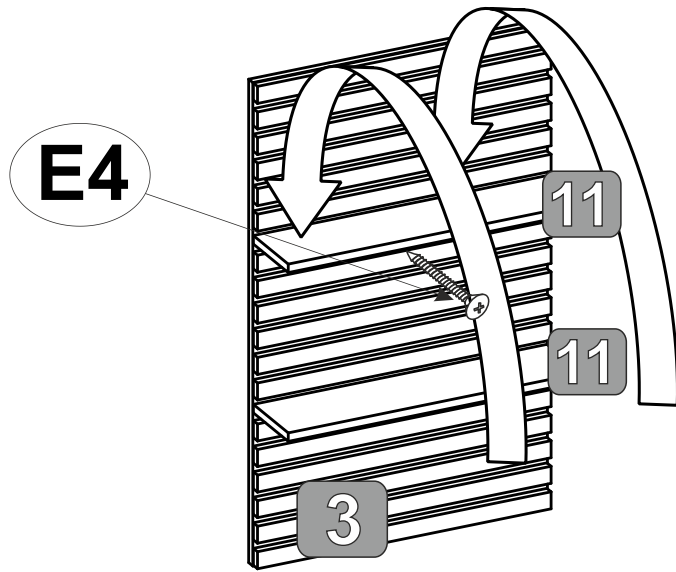
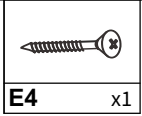

28

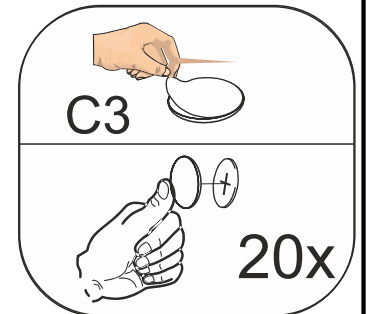
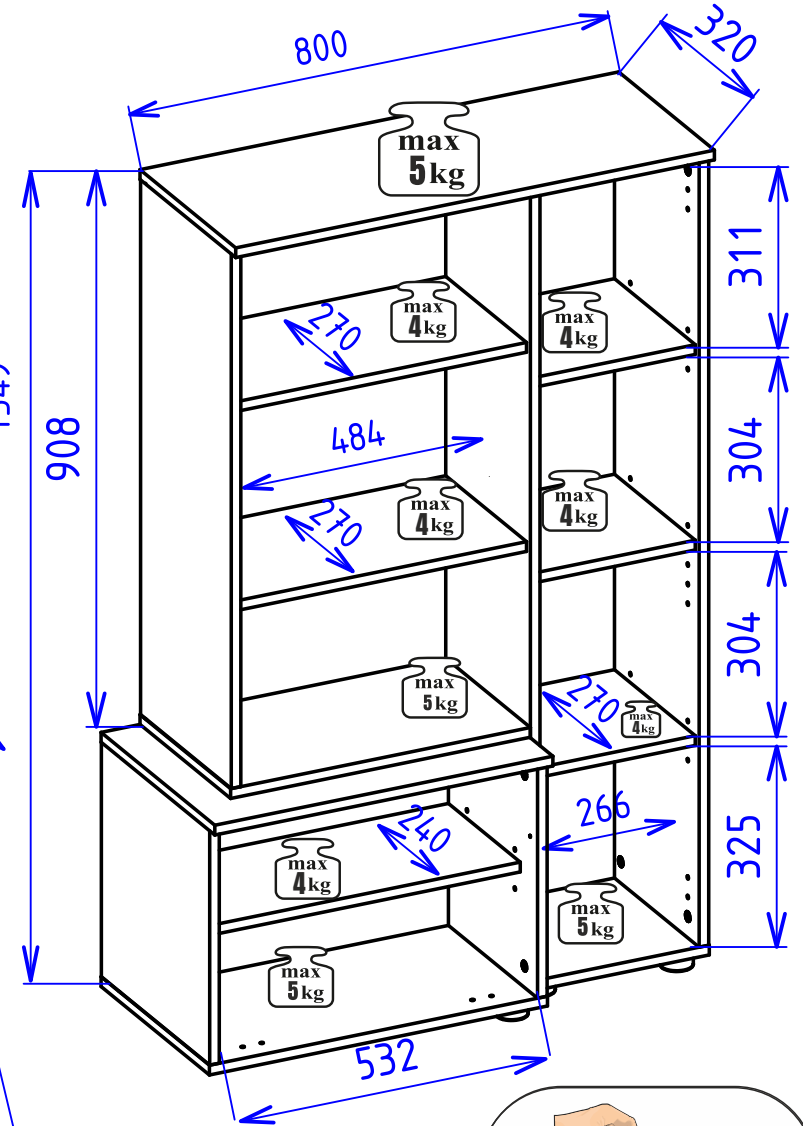
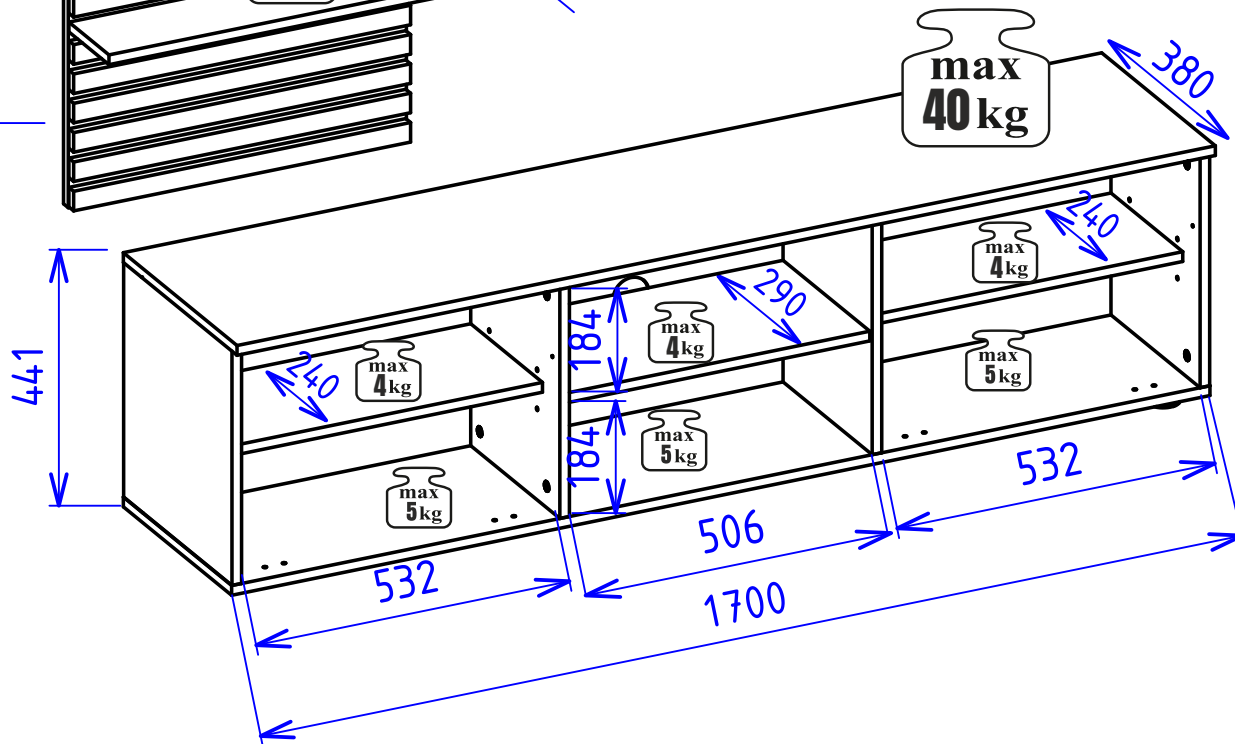
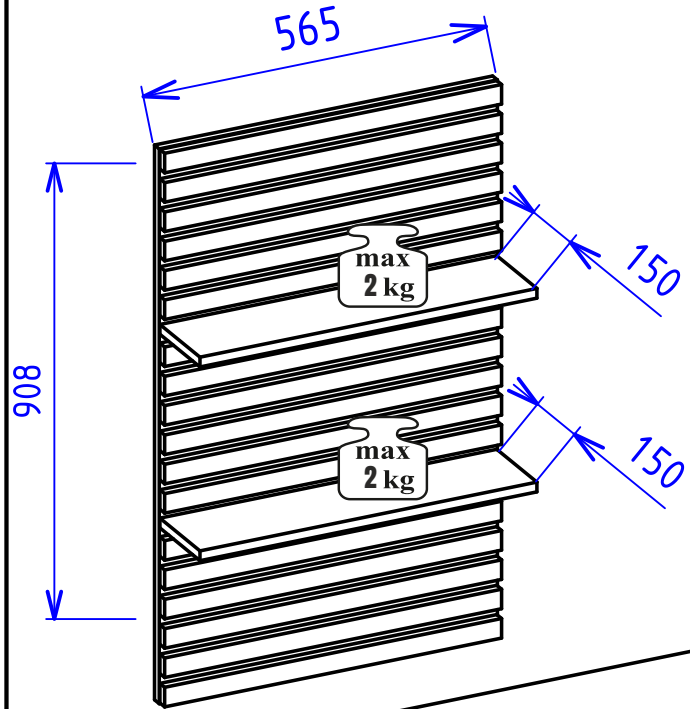
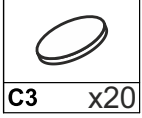

787846

SQUERE2S-PCB-NW

ZES/001/NML

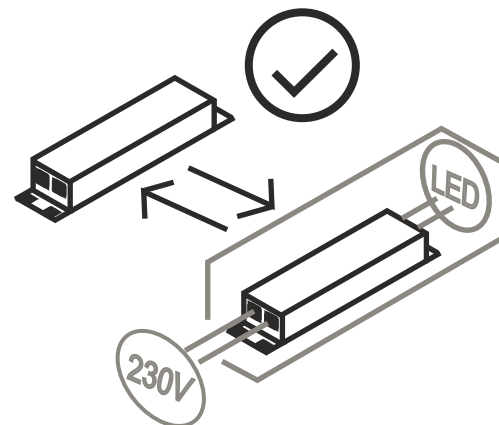
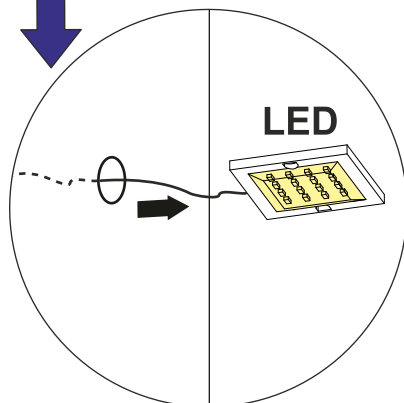
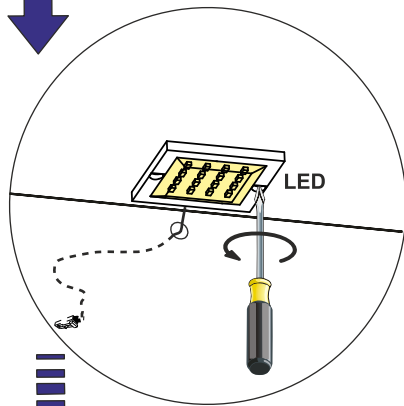
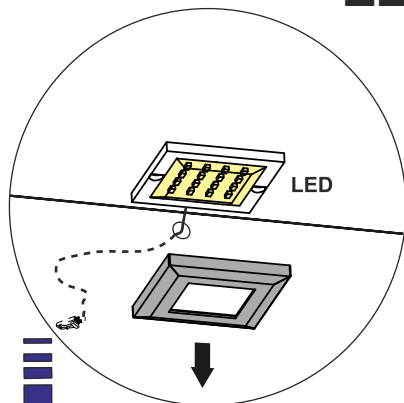

PL- Ten produkt zawiera źródła światła o klasie efektywności energetycznej „F”

DE- Diese Produkte enthalten Lichtquellen der Energieeffizienzklasse „F”

CS- Tento výrobek obsahuje světelný zdroj třídy energetické účinnosti „F”

DA- Dette produkt indeholder en lyskilde til energieffektivitetsklasse „F”

EL- Αυτό το προϊόν περιέχει μια πηγή φωτεινής πηγής ενεργειακής απόδοσης „F”

EN- This product contains a light sources of energy efficiency class „F”

ES- Este producto contiene una fuente de luz de clase de eficiencia energética „F”

ET- See toode sisaldab efektiivsusklassi valgusallikat energia „F”

FI- Tämä tuote sisältää energiatehokkuusluokan valonlähteen „F”

FR- Ce produit contient des sources lumineuses de classe d'efficacité „F”

HU- Ez a termék energiahatékonyági osztályú fényforrást tartalmaz „F”

IT- Questo prodotto contiene una sorgente luminosa di classe di efficienza energetica „F”

LT- Šiame gaminyje yra energijos vartojimo efektyvumo klasės šviesos šaltinis „F”

LV- Šis produkts satur gaismas avotu ar energoefektivitātes klasi „F”

RU- Этот продукт содержит источник света класса энергоэффективности „F”

PT- Este produto contém uma fonte de luz da classe de eficiência energética „F”

RO- Acest produs conține o sursă de lumină de clasă de eficiență energetică „F”

NL- Dit product bevat een lichtbron met energie-efficiëntieklasse „F”

SK- Tento výrobok obsahuje svetelný zdroj triedy energetickej účinnosti „F”

SLO- Ta izdelek vsebuje svetlobni vir razreda energijske učinkovitosti „F”

SV- Denna produkt innehåller en ljuskälla för energieffektivitetsklass „F”

TR- Bu ürün bir ışık kaynağı enerji verimliliği sınıfı içerir „F”

HR- Ovaj proizvod sadrži izvor svjetlosti razreda energetske učinkovitosti „F”

BG- Този продукт съдържа източник на светлина от клас на енергийна ефективност „F”

DE WICHTIG! FÜR SPÄTERES NACHSCHLAGEN AUFBEWAHREN: SORGFÄLTIG LESEN

WARUNG: Kleinteile, Verpackungsbeutel und Folien sind aufgrund von Erstkontaktgefahr und möglichem Verschlucken von Babys und Kleinkindern fernhalten! Um die Gefahr einer Erstickung zu vermeiden, sind Kunststofffüllen nach dem Gebrauch zu entfernen oder zu vernichten. Unsere Möbel werden ausschließlich für den Wohnbereich gefertigt.

Bitte beachten Sie unbedingt die Montageanleitung und beachten Sie diese auf. Bei einer fehlerhaften Montage können wir keine Haftung übernehmen. Nurzen Sie den Artikel nicht, wenn ein konstruktives Bauteil fehlt oder aufgrund einer Beschädigung in seiner Stabilität gefährdet ist. Bei Nichtbeachtung, Änderungen von Produkt oder der Verwendung von nicht originalen Teilen entstehen jegliche Gewährleistungs- bzw. Haftungssprünge. Unseres Sortiment ist ausschließlich für den privaten Gebrauch konzipiert. Bei vielen Artikeln ist die Montageanleitung eine Werbepublikation vorgesehen, sodass Möbel/Schrankanbelangen, sind daher ausschließlich für festes Mauerwerk geeignet. Informieren Sie sich vor der Wandmontage über das geeignete Montagematerial für Ihre Wand und tauschen Sie es ggf. aus. Achten Sie auf den Verfall von wasser- oder stromführenden Leitungen.

- Elektrikkomponenten, die nicht über eine Steckdose mit dem Stromnetz verbunden werden, dürfen nur von entsprechendem geschultem Fachpersonal vorgenommen werden (z.B. Beleuchtungen im Badelzimmer, Herdabschaltung in der Küche). Für alle Elektrokomponenten liegt eine separate Anleitung bei. Bitte beachten Sie diese unbedingt. Enthaltende LED -Beleuchtungen dienen dekorativen Zwecken und sind nicht für die Hauptbeleuchtung eines Raums geeignet.

- Überprüfen Sie regelmäßig die Schraubverbindungen und ziehen Sie diese ggf. nach. Beachten Sie die Belastungsangaben in der Montageanleitung. Zusätzliche Schraubverbindungen für eine stabile Wandbefestigung vorgesehen sein, müssen diese unbedingt montiert werden (z.B. Wandregale, große Hängeschrank, ...).

- **WARNUNG** - Die Eignung der Wand/Docke ist zu überprüfen, um sicherzustellen, dass die Beanspruchungen nicht den erzielten Kraften entsprechen.

- Neue Möbel werden in der Regel einem typischen 8m x 8m, bei Neubauarbeiten wird durch die Freisetzung verschiedener flüchtiger Stoffe aus den verwendeten Materialien in geringsten Konzentrationen erreicht. Diese Stoffe werden nicht nachgelassen und verflüchtigen sich nach entsprechendem Auslüften innerhalb kurzer Zeit selbst. Achten Sie auf eine durchschnittliche Raumtemperatur von ca. 18-23 Grad Celsius und einer Raumfeuchtigkeit zwischen 40 - 55% und üben Sie regelmäßig, um einer Schimmelbildung vor zu beugen. Wenden und drehen Sie die Matten regelmäßig. Entfernen Sie stehende Feuchtigkeit umgehend.

- **Hinweis:** Um Kratzer auf dem Fußboden zu vermeiden bitte die Polstermöbel vorsichtig anheben, NICHT schleifen, kippen oder ziehen.
- **Hinweis:** Wenn das Stirnbein über eine Stützheilverstellmechanismen mit Energiespeicher verfügt, weisen wir Sie darauf hin, dass nur geschultes Personal die Stützheilverstellmechanismen mit Energiespeicher austauschen oder instand setzen darf.

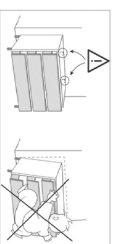
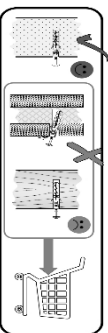
**GB IMPORTANT! RETAIN FOR FUTURE REFERENCE. READ CAREFULLY**

WARNING: Keep small parts, packaging bags, and films out of reach of babies and toddlers due to the risk of suffocation and possible swallowing! To avoid the risk of suffocation, plastic covers must be removed or destroyed after use. Our furniture is manufactured exclusively for residential use.

To avoid the risk of suffocation, plastic covers should be removed before use. Destroy or keep covers away from children.

- Please strictly follow the assembly instructions and keep them for future reference. We cannot accept any liability for incorrect assembly. Do not use the item if any structural component is missing or damaged, compromising its stability. Many items require wall mounting. If dowels/screws are included they are only suitable for solid masonry. Inform yourself about the suitable mounting material for your wall before mounting and replace it if necessary. Pay attention to the layout of water or electrical lines.

- Electrical components that are not connected to the power grid via a socket should only be installed by appropriately trained professionals (e.g., lighting in bathrooms, stove connections in kitchens). A separate manual is included for all electrical components. Please be sure to follow it. Included LED lighting is for decorative purposes and is not suitable for the main lighting of a room.

- Regularly check screw connections and tighten them if necessary. Observe the load specifications in the assembly instructions. If additional safety screws are provided in the assembly instructions for secure wall mounting, they must be installed (e.g., wall shelves, large hanging cabinets, etc.).

- New furniture typically emits a characteristic odor. The new furniture smell is caused by the release of various volatile substances from the materials used in very small concentrations. These substances are not regulated and dissipate on their own after adequate airing within a short time. Maintain an average room temperature of approximately 18-23 degrees Celsius and a room humidity level between 40-55%, and ventilate regularly to prevent mold formation. Turn and rotate mattresses regularly to prevent indentations. Clean the furniture with slightly damp cotton cloths. Avoid microfibre cloths and cleaning agents with abrasive or solvent-containing additives. Remove standing moisture immediately.

- **Note:** To avoid scratches on the floor, carefully lift upholstered furniture. Do NOT push, tilt, or drag.

- **Note:** If the seating furniture has a seat height adjustment device with an energy storage unit, please note that only trained personnel may replace or repair these devices.

- **WARNING** - Check the suitability of the wall/ceiling to ensure that the fastening devices can withstand the applied forces.

FR IMPORTANT! À CONSERVER POUR TOUTE CONSULTATION ULTÉRIEURE. À LIRE ATTENTIVEMENT

MISE EN GARDE: Gardez les petites pièces, les sacs d'emballage et les films hors de portée des bébés et des tout-petits en raison du risque d'étouffement et de possible ingestion! Pour éviter tout risque d'étouffement, les housses en plastique doivent être retirées ou détruites après usage. Nos meubles sont fabriqués exclusivement pour un usage résidentiel.

Pour éviter le risque d'étouffement, les couvertures en plastique doivent être retirées avant utilisation. Détruisez les couvertures ou gardez-les hors de portée des enfants.

- Veuillez suivre strictement les instructions de montage et les conserver pour référence future. Nous ne pouvons accepter aucune responsabilité en cas de montage incorrect. Nullifiez toute garantie si un composant structurel manque ou est endommagé, compromettant sa stabilité. Le non-respect des instructions de montage, de nombreux articles nécessitent une fixation murale. Si des chevilles/vifs sont incluses, elles ne sont adaptées que à la maçonnerie solide. Informez-vous sur le matériau de montage approprié pour votre mur avant de procéder au montage et remplacez le si nécessaire. Faites attention à l'emplacement des conduits d'eau ou électriques.

- Les composants électriques qui ne sont pas connectés au réseau électrique via une prise doivent être installés uniquement par des professionnels formés (par exemple, éclairage dans les salles de bains, connexions de cuisine dans les cuisines). Un manuel séparé est inclus pour tous les composants électriques. Veuillez la suivre impérativement. Les éclairages LED inclus sont destinés à des fins décoratives et ne conviennent pas pour l'éclairage principal d'une pièce.

- Vérifiez régulièrement les connexions des vis et serrez-les si nécessaire. Respectez les spécifications de charge dans les instructions de montage. Si des vis de sécurité supplémentaires sont prévues dans les instructions de montage pour une fixation murale sécurisée, elles doivent être installées (par exemple, étagères murales, grands placards suspendus, etc.).

- Les nouveaux meubles dégagent généralement une odeur caractéristique. L'odeur des meubles ne doit pas être une cause de préoccupation, car elle provient de divers substances volatiles provenant des matériaux utilisés en très petites concentrations. Ces substances ne sont pas réglementées et disparaissent d'elles-mêmes après une aération adéquate en peu de temps. Maintenez une température ambiante moyenne d'environ 18-23 degrés Celsius et un taux d'humidité de 40-55%, et vérifiez régulièrement la formation de moisissures. Retournez et faites pivoter les matelas régulièrement pour éviter les creux. Nettoyez les meubles avec des chiffons en coton légèrement humides. Évitez les chiffons en microfibre et les agents de nettoyage contenant des additifs abrasifs ou des solvants. Éliminez immédiatement l'humidité stagnante.

- **Remarque :** Le lit est équipé d'un dispositif de réglage de la hauteur avec accumulateur d'énergie. Ne posez pas, ne basculez pas, ne tirez pas.

- **AVERTISSEMENT** - Vérifiez la solidité du mur/plafond afin de garantir que les dispositifs de fixation résistent aux forces exercées.

PL WAŻNE! ZACHOWAĆ DO PÓŹNIEJSZEGO WGLĄDU. PROSZĘ UWAŻNIE PRZECZYTAĆ

OSTRZEŻENIE: Trzymaj małe części, worki opakowaniowe i folie z dala od niemowląt i małych dzieci w związku na ryzyko uduszenia i możliwości pokłnięcia! Aby uniknąć ryzyka uduszenia, należy usunąć lub zniszczyć plastikowe osłony po użyciu. Nasze meble są produkowane wyłącznie do użytku domowego.

- Aby uniknąć ryzyka uduszenia, należy przed użyciem usunąć plastikowe osłony. Osłony należy zniszczyć lub trzymać z dala od dzieci.

- Prosimy o ścisłe przestrzeganie instrukcji montażu i zachowania ich do przyszłego użycia. Nie możemy odpowiedzialności za nieprawidłowy montaż. Nie używaj produktu, jeśli brakuje jakiegokolwiek elementu konstrukcyjnego lub jest on uszkodzony, co wpływa na jego stabilność. Nieprzeznaczone instrukcji, wprowadzanie zmian w produkcie lub użycie nieoriginálnych części powoduje utratę gwarancji. Uszkodzone części lub uszkodzone części konstrukcyjne. Nasze wyposażenie jest przeznaczony wyłącznie do użytku prywatnego. Zgodnie z instrukcją montażu wiele produktów wymaga mocowania do ściany. Jeśliś dołączony są kołki/wkręty, są one odpowiednie wyłącznie do mocnego muru. Przed montażem na ścianie sprawdź odpowiedni materiał montażowy do swojej ściany i w razie potrzeby wymień go. Zwróć uwagę na przedbieg przewodów wodnych i elektrycznych.

- Elementy elektryczne, które nie są podłączone do sieci elektrycznej za pomocą gniazdek, powinny być instalowane wyłącznie przez odpowiedzialny personelu (np. oświetlenie w łazienkach, podłączenia kuchenne w kuchniach). Do wszystkich elementów elektrycznych dołączona jest osobna instrukcja. Prosimy o jej ścisłe przestrzeganie. Ołączane oświetlenie LED służy celom dekoracyjnym i nie należy się do głównego oświetlenia pomieszczenia.

- Regularnie sprawdzaj połączenia śrubowe i w razie potrzeby dokręcaj je. Przestrzegaj obciążeni podanych w instrukcji montażu. Jeżeli w instrukcji montażu przewidziane są dodatkowe śruby zabezpieczające do obrotu mebla sprawnie do ściany, muszą one zostać zamontowane (np. półki ściennie, duże szafki wiszące, itp.).

- Nowe meble zazwyczaj emitują charakterystyczny zapach. Zapach nowych mebli jest spowodowany uwolnieniem różnych lotnych substancji z użytych materiałów w bardzo małych stężeniach. Substancje te nie są regulowane i dissipują same po odpowiednim przewietrzeniu w krótkim czasie. Utrzymuj średnią temperaturę w pomieszczeniu na poziomie około 18-23 stopni Celsjusza oraz wilgotność powietrza między 40-55% względnie w miarę pomieszczenia, aby zapobiec powstawaniu pleśni. Regularnie obracaj i odwracaj materace, aby zapobiec tworzeniu się wgłębień. Czyść meble lekko wilgotnymi bawełnianymi szmatkami. Unikaj

- **Uwaga:** Aby uniknąć ryzyka uduszenia, osłony podłogi nie należy usuwać. Nie przesuwaj, nie przeciągaj, nie ciągnij.

- **Uwaga:** Jeśli meble posiadają mechanizm regulacji wysokości z akumulatorem energii, informujemy, że tylko wykwalifikowany personel może go wymienić lub naprawić.

- **OSTRZEŻENIE** - Sprawdź, czy ściana/wyścił jest odpowiedni, aby upewnić się, że elementy mocujące wytrzymałają działanie sily.

IT IMPORTANT! CONSERVARE PER CONSULTAZIONE FUTURA. LEGGERE CON ATTENZIONE

ATTENZIONE: Tenere piccole parti, sacchetti di imballaggio e pellicole lontano da neonati e bambini piccoli a causa del rischio di soffocamento e possibile ingestione! Per evitare il rischio di soffocamento, le coperture in plastica devono essere rimosse o distrutte dopo l'uso. I nostri mobili sono realizzati esclusivamente per uso domestico.

Per evitare il rischio di soffocamento, rimuovere le coperture di plastica prima dell'uso. Distruggi o tieni le coperture lontano dai bambini.

- Si prega di seguire attentamente le istruzioni di montaggio e conservarle per future referenze. Non possiamo accettare alcuna responsabilità per il montaggio errato. Non utilizzare l'articolo se manca un componente strutturale o è danneggiato, compromettendone la stabilità. Il mancato rispetto, l'uso di parti non originali annulleranno qualsiasi garanzia e richiesta di risarcimento. La nostra gamma è progettata esclusivamente per uso privato. Secondo le istruzioni di montaggio, molti articoli richiedono il fissaggio a parete. Se sono inclusi tasselli/viti, questi sono adatti solo per muratura solida. Informarsi sul materiale di montaggio adatto per la propria parete prima del montaggio e sostituirlo se necessario. Prestare attenzione al percorso delle tubature dell'acqua o dei cavi elettrici.

