

# AUDI Q8

## BATTERY OPERATED RIDE-ON

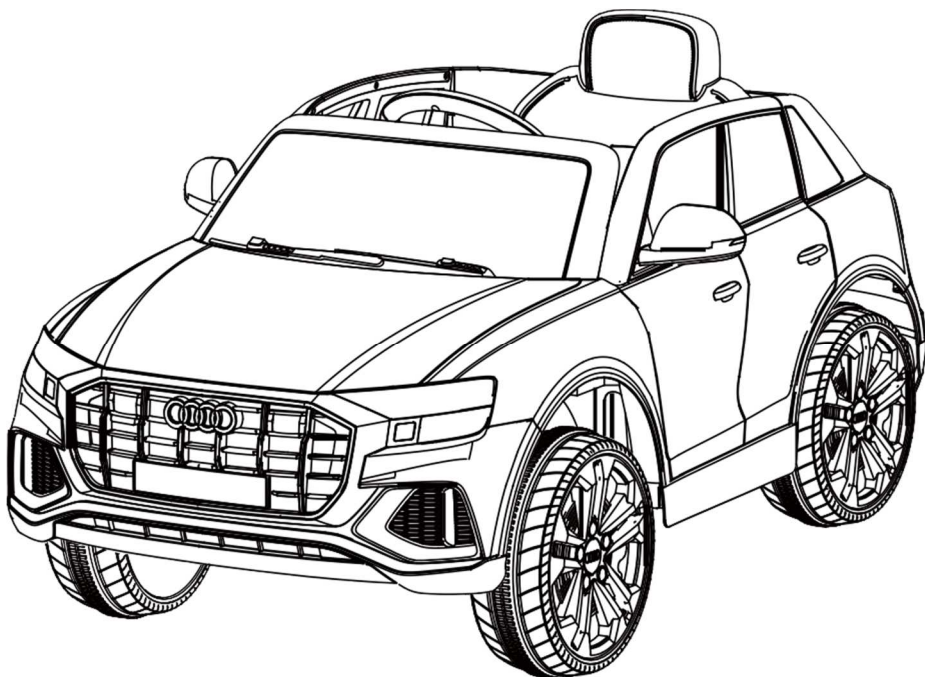

## Owner's Manual with Assembly Instructions

Styles and colo(u)rs may vary.  
Made in China.

The owner's manual contains important safety information as well as assembly, use and maintenance instructions.

The Ride-on Car must be assembled by an adult who has read and understands the instructions in this manual.

Keep the package away from children and dispose of properly before use.

**Keep this manual for future reference.**

On the purchase of your new Ride-On.

This ride-on will provide your child with many miles of riding of enjoyment. To help assure you and your rider a safe ride we ask you to please read this manual carefully, and keep it for future reference.

Follow the recommendations in this manual, they are designed to improve the safety and operation of your ride-on car and it's rider.

Trademarks, design patents and copyrights are used with the approval of owner AUDI AG.

## SPECIFICATIONS:

<b>Battery</b>	6V7AH*1 or 6V10AH *1	12V4AH *1
<b>Charger</b>	6V1000mA	12V500mA

**Suitable age:** 37-96 months

**Load Capacity:** Under 30kg

**Speed:** **1WD** 3km/h **2WD 4WD** 3-5km/h

**Size of car:** 108.5 x 63 x 51.5 CM

**Power way:** Charging type

**Charge time:** 8-12 hours

 **WARNING!**

- **CHOKING HAZARD** - Small parts. Not suitable for children under 36 months. The product contains small parts, keep children away when assembling.
- **ADULT ASSEMBLY REQUIRED.**
- Always remove protective material and poly bags and dispose before assembly.
- Protective equipment should be worn. Always wear shoes and sit in the seat when operating the vehicle.
- Only drive on level ground. Never use on the lawn.
- Never leave a child unattended.
- Keep your hands, hair, and clothes away from moving parts.

 **SAFETY**

The following safety hazards may result in serious injury or death:

- Never leave child unattended. Direct adult supervision is required. Always keep child in view when child is in vehicle.
- Never use in roadways, near streets, motor vehicles, steps, bodies of water, sloped surfaces, hills, wet areas, flammable vapors, in alleys, at night, or in the dark.
- Never use in unsafe conditions such as snow, rain, loose dirt, mud, sand, or gravel, otherwise may result in an unexpected accident such as tipping over, and could damage the electrical system or battery
- Not to be used in traffic.
- This toy should be used with caution since skill is required to avoid falls or collisions causing injury to the user or third parties.
- This toy is unsuitable for children under 36 months due to its maximum speed; Maximum user weight is 30kg.
- This toy has no brake.

 **BATTERY INFORMATION**

- Non-rechargeable batteries are not to be recharged.
- Rechargeable batteries are to be removed from the toy before being charged.
- Rechargeable batteries are only to be charged under adult supervision.
- Different types of batteries or new and used batteries are not to be mixed.
- Batteries are to be inserted with the correct polarity.
- Exhausted batteries are to be removed from the toy.
- The supply terminals are not to be short-circuited.

# Parts Diagram | 3

HINT: Some parts shown are assembled on both sides of vehicle

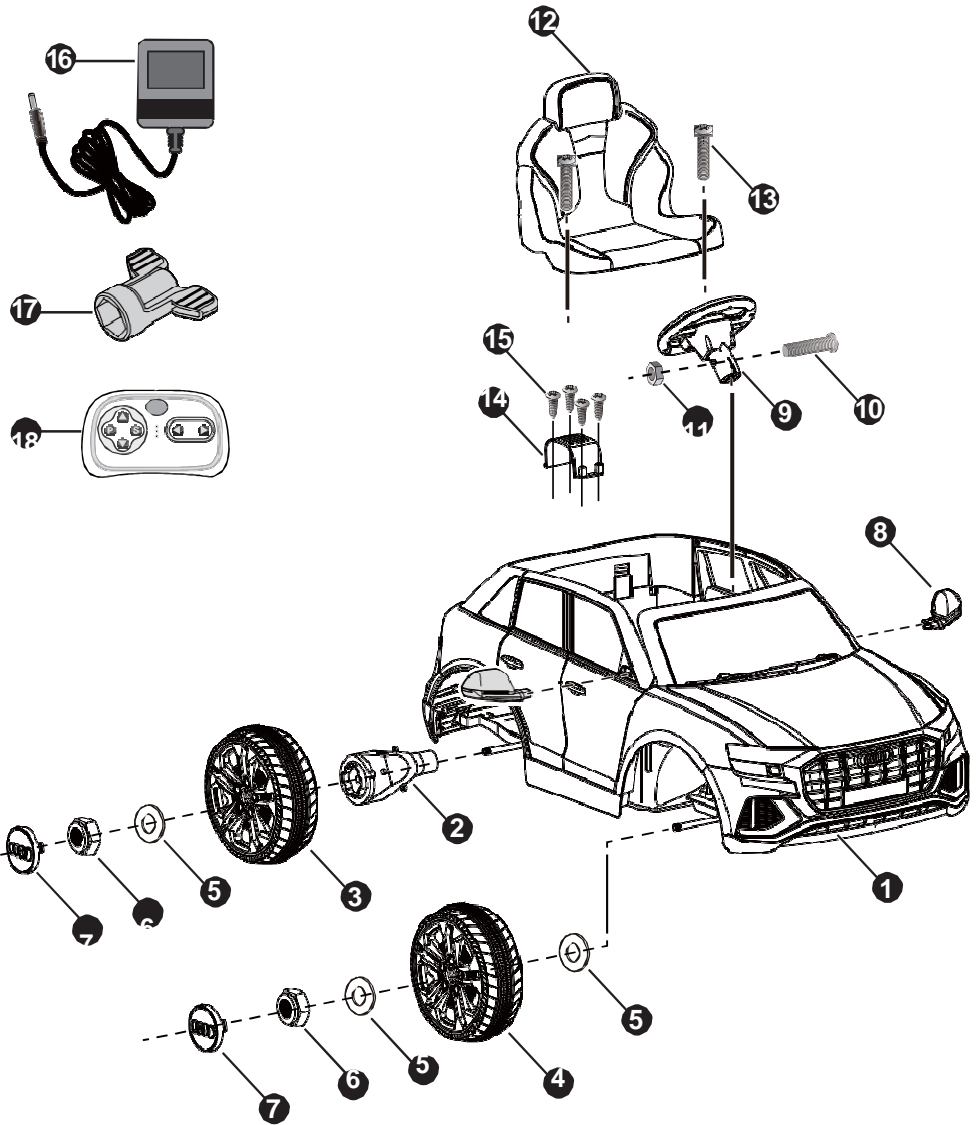

# Parts List | 4

PART NO.	PART NAME	Q'ty (pcs)		REMARKS
		1WD	2WD	
1	Vehicle body	1	1	
2	Rear gear box	1	2	2WD 1 PC labeled "R", the other one labeled "L"
3	Rear wheel	2	2	
4	Front wheel	2	2	
5	Ø10 washer	7	6	
6	Lock nut	4	4	
7	Hubcap	4	4	
8	View mirror	2	2	Left and right
9	Steering wheel	1	1	
10	M5x40 machine screw	1	1	Placed on the steering wheel
11	Ø5 nut	1	1	Placed on the steering wheel
12	Seat	1	1	
13	M5x16 screw	2	2	
14	Motor Hood	1	2	
15	Motor Hood	4	8	
16	Ø4x12 screw	1	1	
17	Charger	1	1	
18	Spanner	1	1	
18	Remote controller			

## Assembly tools required (not included):



**Screwdriver**

**HINT: If your vehicle is Two / Four Wheels Driving Type, see the next page please.**

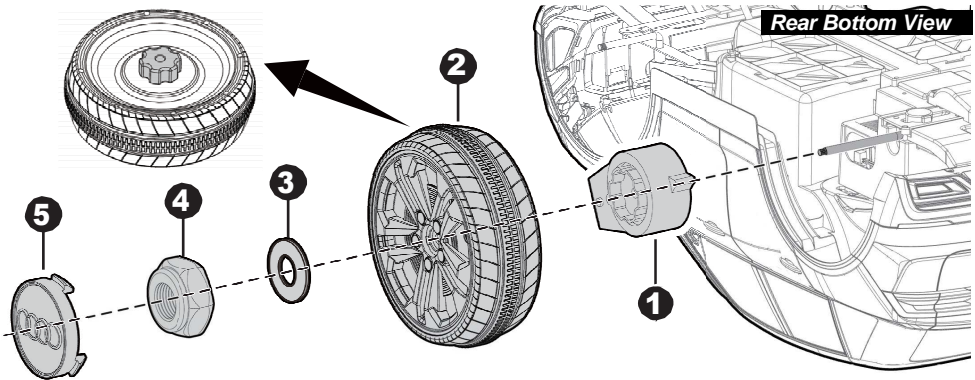

Remove all the parts from the rear axle.

1. Slide the **rear gear box** onto the rear axle from **Left Side** ("R" labeled gear box should be fit to the "R" side, "L" labeled gear box should be fit to the "L" side), keep the connector and the motor on the gear box pass through the larger hole and out where the battery sits.
2. Slide the **rear wheel** onto the rear axle. Keep it match up with the gear box.
3. Slide a **Ø10 washer** onto the rear axle.
4. Tighten a **lock nut** to the end of the rear axle with a spanner.
5. Fit the **hubcaps** to the wheel.

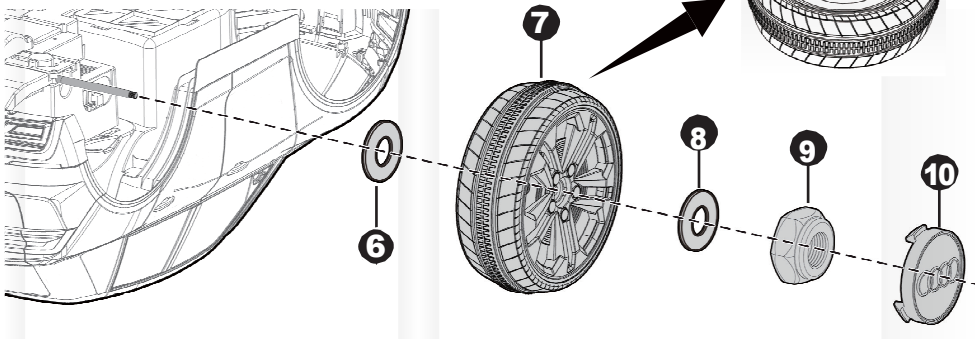

- 6 Slide the **Ø10 washer** onto the rear axle (**Right Side**).
7. Slide the **rear wheel** onto the rear axle.
8. Slide the **Ø10 washer** onto the rear axle.
9. Tighten a **lock nut** to the end of the rear axle with a spanner. **HINT: An extra spanner has been provided to hold the Lock Nut on the other side of the rear axle while tightening the Lock Nut on the other side.**
10. Fit the **hubcaps** to the wheel.

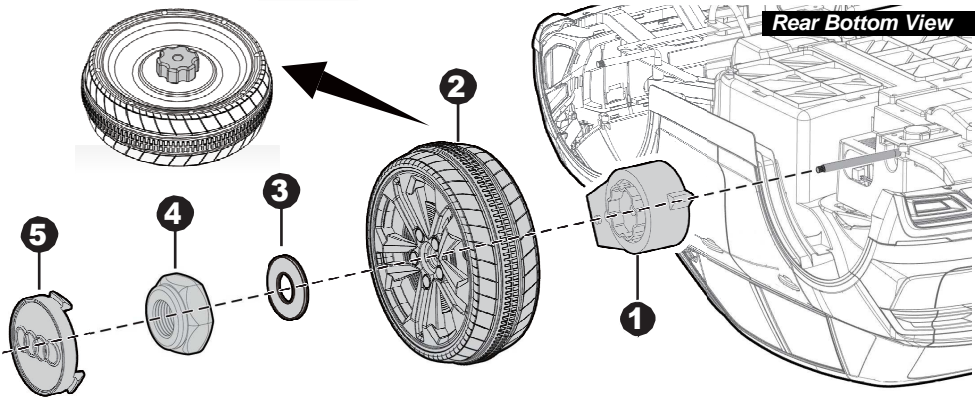

Remove all the parts from the rear axle.

1. Slide the **rear gear box** onto the rear axle. “R” labeled gear box should be fit to the “R” side of vehicle body; “L” labeled gear box should be fit to “L” side of vehicle body. Keep the motor and the connector on the gear box pass through the larger hole on the rear of the vehicle and out where the battery sits.
2. Slide the **rear wheel** onto the rear axle. And keep the driving wheel match up with the gear box.
3. Slide the **Ø10 washer** onto the rear axle.
4. Tighten a **lock nut** to the end of the rear axle with a spanner.
5. Fit the **hubcaps** to the wheels.

**Repeat** the above procedure to assemble the **other rear wheel**.

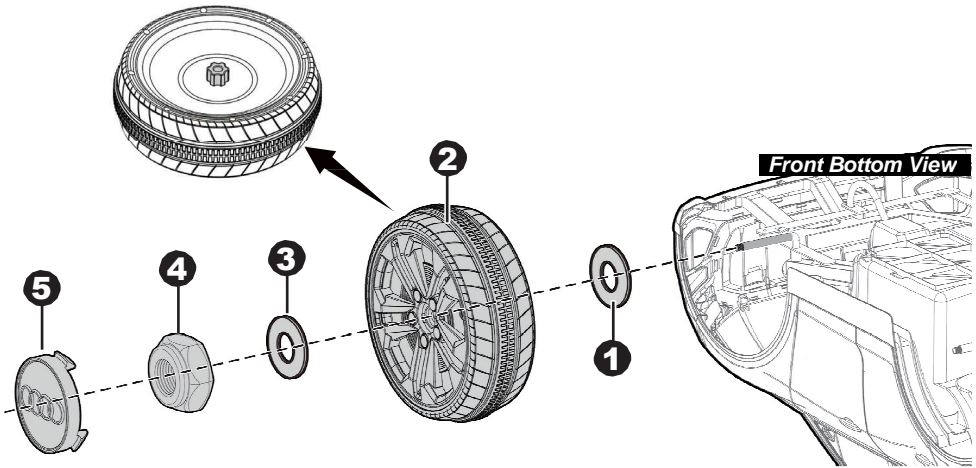

Remove all the parts from the front axle.

1. Slide a **Ø10 washer** onto the front axle.
2. Slide a **front wheel** onto the front axle.
3. Slide a **Ø10 washer** onto the front axle.
4. Tighten a **lock nut** to the end of the front axle with a spanner.
5. “Snap” the **hubcap** to the wheel.

Repeat the above procedure to assemble the other normal wheel.

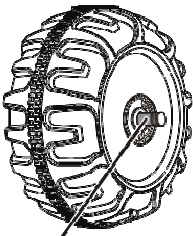

**GAP**

After assembling any wheel to the axles, please check the gap between the screw thread and the collapsible (refer to below picture), if the gap is too big, please add two or three washers inside the wheel, but after tightening the nut outside the wheel, please turn the wheel by your finger to check if the wheel can run smoothly, this is very important, because if the wheel can run smoothly, it is ok, but if the nut press the wheel and the wheel can't run smoothly, the motor will be broken easily! Then you need to decrease one or two washers to make sure the wheel can run smoothly!



**HINT:** If the steering wheel of your vehicle equipped with the sound function, please follow the steps 1-4 to add the batteries (Not Included), and refer to the battery information on page 2.

1. With a screwdriver remove the screw on the **battery cover** located in the center of the steering wheel.
2. Remove the **battery cover** from the top of the **battery compartment**.
3. Insert 2x1.5 **AA batteries** in their correct polarities.
4. Place the **battery cover** over the **battery compartment** and fasten with the screw you removed in step one.

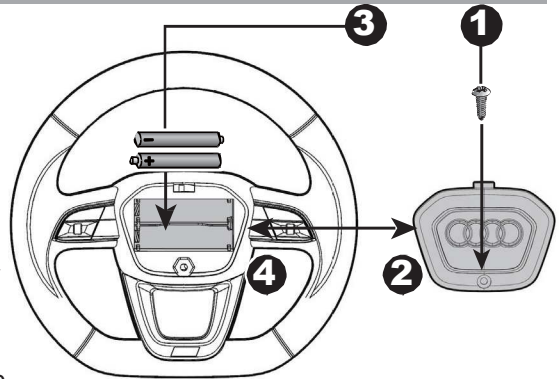

## Attach the Steering Wheel

Remove the **M5x40 machine screw** and **Ø5 nut** from the **steering wheel**. Turn the vehicle body upright.

5. Place the **steering wheel** over the the steering column, protruding from the middle of the **steering wheel base**.
6. Align the holes on each side of **steering wheel** with the holes at the **end of the steering column**.
7. Fasten a **nut** on the opposite end of the **screw** to secure the steering wheel to the steering column.

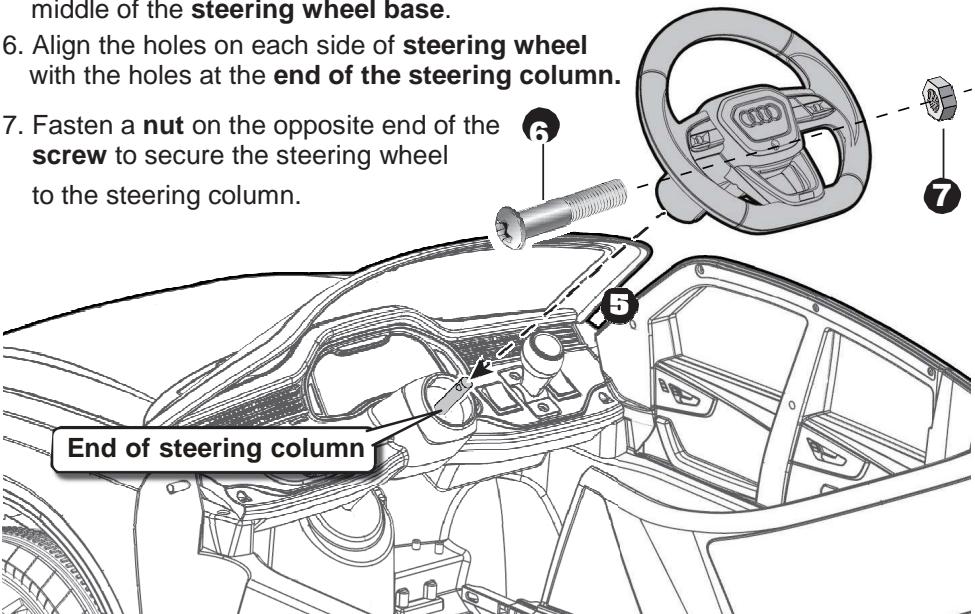

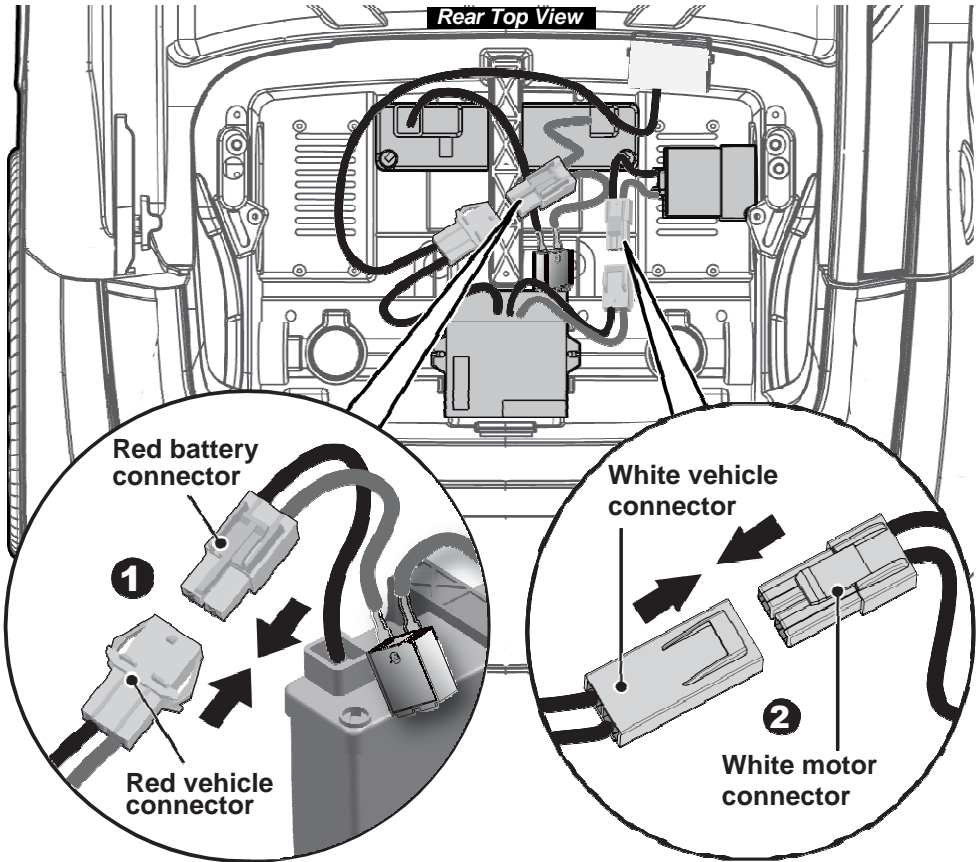

## 1WD

1. Plug the **red fuse connector** into the terminal on battery.
2. Plug the **vehicle connector** into the **motor connector** on body as shown above.

## 2WD

1. Plug the **red fuse connector** into the terminal on battery.
2. Plug the **vehicle connector** into the **motor connector** on body as shown above. Repeat for the other side.

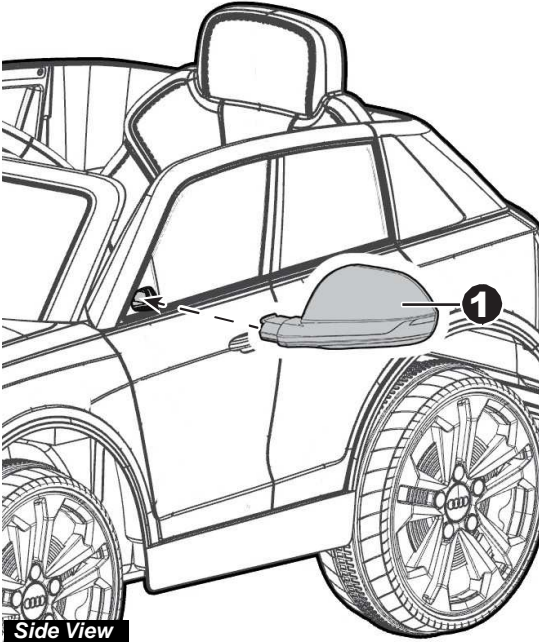

Side View

1. Insert the **mirror** into the hole on the side of the vehicle. Push until you hear it “click” into place. Repeat for the other side.
2. Fit the **motor hood** over the motor.
3. Insert four **Ø4x12 screws** and tighten.

**2WD** Repeat for the other motor hood.

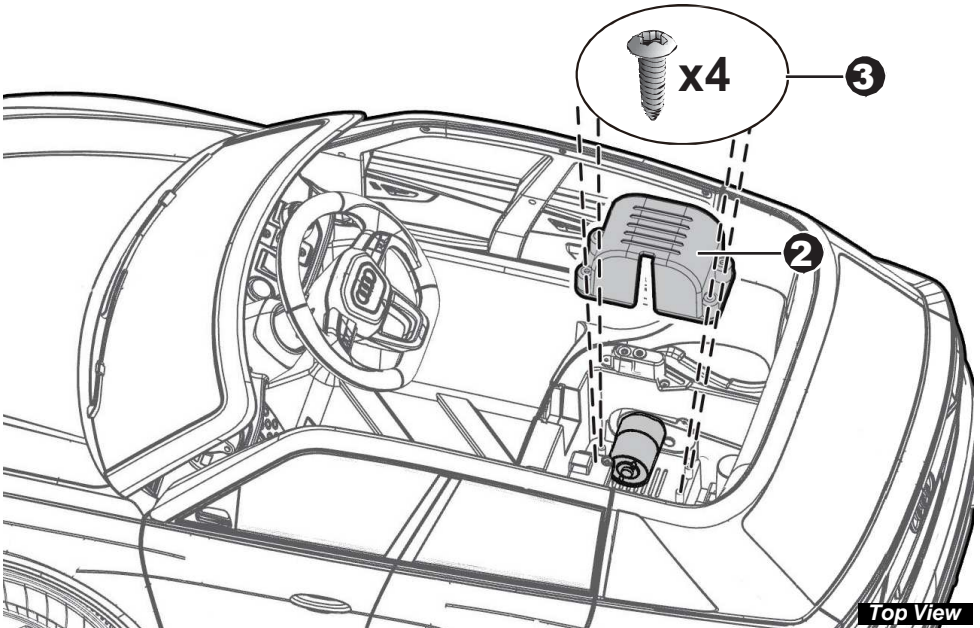

Top View

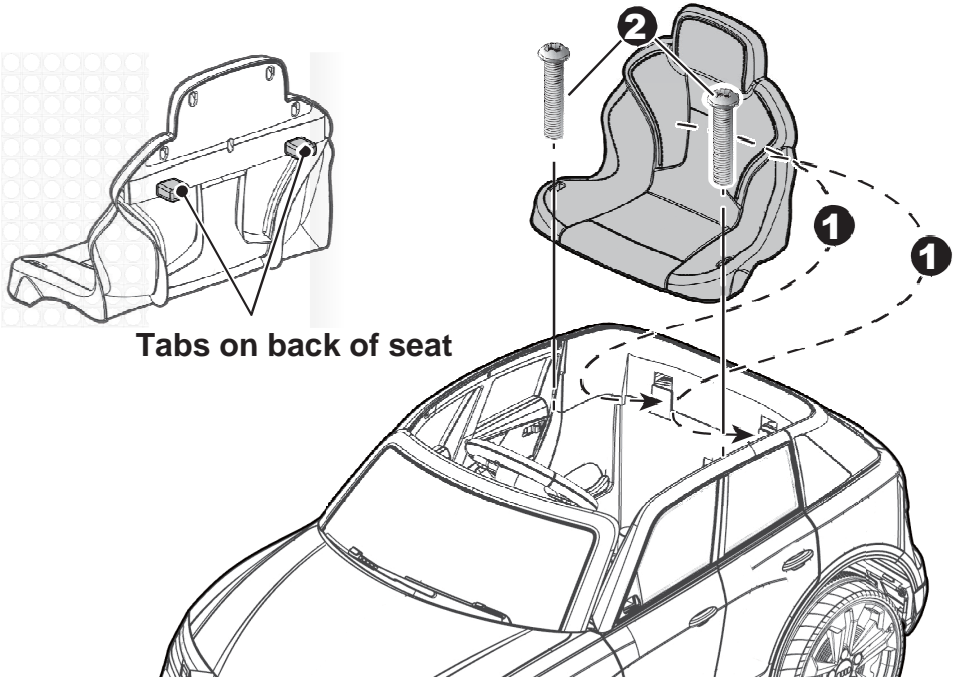

Tabs on back of seat

1. Fit the tabs **on back of the seat** into the grooves on the rear of the vehicle.
2. Insert two **M5x16 machine screws** through the seat and into the vehicle body, and tighten them with a screwdriver.

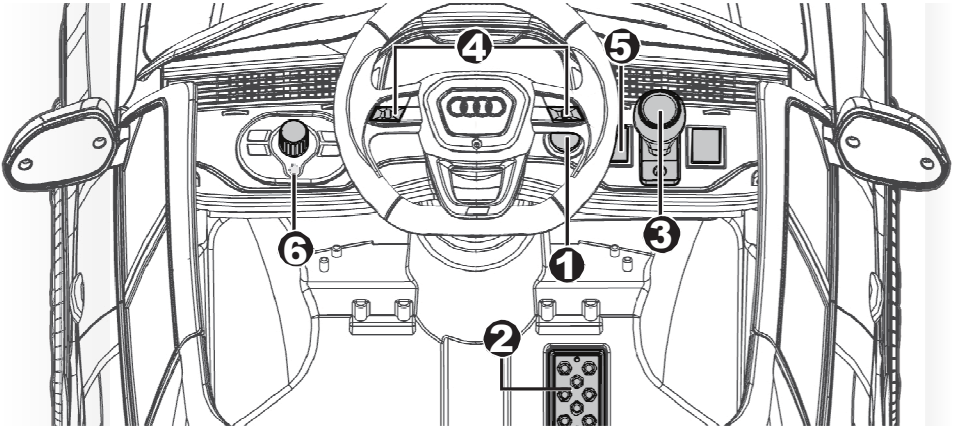

1. **Power button:** Turns the vehicle on and off.
2. **Foot pedal:** Applies power (speed) to the vehicle.
  - To move the car, press the pedal down.
  - To brake or slow down, release pressure from the pedal.
3. **Forward/reverse switch:** Changes the direction that vehicle moves from forward to reverse.
  - To move the vehicle forward, shift the lever to top position.
  - To move the vehicle backward, shift the lever to down position.
4. **Sound buttons (if equipped):** Press for sound playing.
5. **High/Low speed switch (if equipped):**

Operates the vehicle to move forward in high speed or low speed.

**HINT:** The vehicle is designed to operate in low speed only in reverse.
6. **3.5mm AUX input :** Allow the audio from your portable music player or phone to be played through the ride-on speakers.



## ⚠️ WARNING!

- **ONLY** an adult is allowed charge and recharge the battery!
  - This product with **Charging Protection**: when charging, all functions will be cut off.
- The POWER SWITCH must be turned in **OFF** position when charging.
  - Before the first use, you should charge the battery for 4-6 hours. Do not recharge the battery for more than 10 hours to avoid overheating the charger.
  - When the vehicle begins to run slowly, recharge the battery.
  - After each use or once a month minimum recharge time as 8 to 12 hours, less than 20 hours at most.
  - Use the only rechargeable battery and charger supplied with your vehicle. **NEVER** substitute the battery or the charger with another brand. Using another battery or charger may cause a fire or explosion.
  - Do not use the battery or charger for any other product.
  - If your ride-on with a **Digital voltmeter(IF EQUIPPED)**, the magnitude of voltage will tell you how much power is remaining in the battery when you must recharge the battery. Make sure the vehicle is stop!

6V product	less than 6.2	<b>The battery needs to be charge.</b>
12V product	less than 12.5	

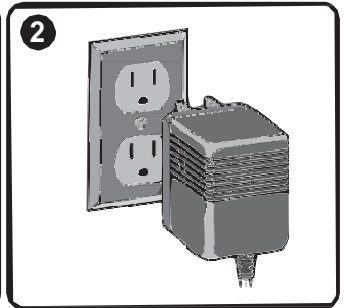
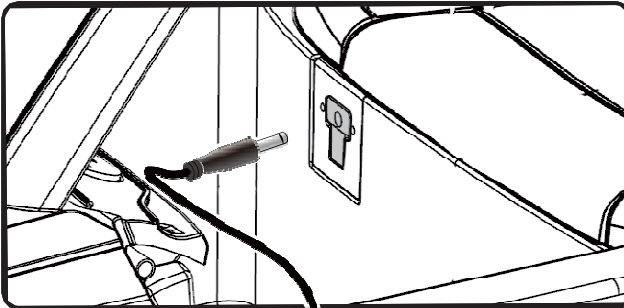

1. Plug the charger port into the input socket (the socket below the seat).
2. Plug the charger plug into a wall outlet. The battery will begin charging.

### Battery Disposal



The battery will eventually lose the ability to hold a charge. Depending on the amount of use, and varying conditions, the battery should operate for one to three years.

**Important!** Recycle the dead battery responsibly. The battery contains lead acid (electrolyte) and must be disposed of properly and legally. It is illegal in most areas to incinerate lead acid batteries or dispose of them in landfills. Take it to a federal or state-approved lead acid battery recycler, such as local automotive battery retailer. Do not throw the battery away with your regular household waste!

Problem	Possible Cause	Solution
Vehicle does not run	Battery low on power	Recharge battery.
	Thermal fuse has tripped	Reset fuse, see <Fuse>
	Battery connector or wires are loose	Check that the battery connectors are firmly plugged into each other. If wires are loose around the motor <b>contact your distributor please.</b>
	Battery is dead	Replace battery, <b>contact your distributor please.</b>
	Electrical system is damaged	<b>Contact your distributor please.</b>
	Motor is damaged	<b>Contact your distributor please.</b>
Vehicle does not run very long	Battery is under charged	Check that the battery connectors are firmly plugged into each other when recharging
	Battery is old	Replace battery, <b>contact your distributor please.</b>
Vehicle runs sluggishly	Battery low on power	Recharge battery, <b>contact your distributor please.</b>
	Battery is old	Replace battery, <b>contact your distributor please.</b>
	Vehicle is overload	Reduce weight on vehicle.
	Vehicle is being used in harsh conditions	Avoid using vehicle in harsh conditions, see <Safety>.
Vehicle needs a push to go forward	Poor contact of wires or connectors	Check that the battery connectors are firmly plugged into each other. If wires are loose around the motor, <b>contact your distributor please.</b>
	“Dead Spot” on motor	A dead spot means the electric power is not being delivered to the terminal connection and the vehicle needs repair. <b>Contact your distributor please.</b>
Difficult shifting from forward to reverse or vice-versa	Attempting to shift while the vehicle is motion	Completely stop the vehicle and shift, see <Use Your Ride-On>
Loud grinding or clicking noises coming from motor or gearbox	Motor or gears are damaged	<b>Contact your distributor please.</b>
Battery will not recharge	Battery connector or adapter connector is loose	Check that the battery connectors are firmly plugged into each other.
	Charger not plugged in	Check that the battery charger is plugged into a working wall outlet.
	Charger is not working	<b>Contact your distributor please.</b>
Charger feels warm when recharging	This is normal and not a cause for concern	

Completely read through this manual and the troubleshooting guide table before calling. If you still need help resolving the problem **Contact your distributor please.**

- It is parents' responsibility to check main parts of the toy before using, Must regularly examine for potential hazard, such as the battery, charge, cable or cord, plug, screws are fastening enclosure of other parts and that in the event of such damage, the toy must not be used until that damage had been properly removed.
- Park the vehicle indoors or cover it with a tarp to protect it from wet weather.
- Recharge the battery after each use. Only an adult can handle the battery. Recharge the battery at least once a month when the vehicle raider is not being used.
- Do not wash the vehicle with a hose. Do not wash the vehicle with soap and water. Do not drive the vehicle in rainy or snowy weather. Water will damage the motor, electric system and battery.
- Clean the vehicle with a soft, dry cloth. To restore shine to plastic parts, use a non-wax furniture polish. Do not use car wax. Do not use abrasive cleaners.
- When not using, all the electrical source should be turn off. Turn off the power switch and disconnect the battery connection.

## Fuse

The battery features a thermal fuse with a reset fuse that will automatically trip and cut all power to the vehicle if the motor, electric system or battery is overloaded. The fuse will reset and power will be restored after the unit is turned OFF for 20 seconds and then turned ON again. If the thermal fuse trips repeatedly during normal use, the vehicle may need repair. **Contact your distributor please.**

To avoid losing power, follow these guidelines:

- Do not overload the vehicle.
- Do not tow anything behind the vehicle.
- Do not drive up steep slopes.
- Do not drive into fixed objects, which may cause the wheels to spin, causing the motor to overheat.
- Do not drive in very hot weather, components may overheat.
- Do not allow water or other liquids to come in contact with the battery or other electric components.
- Do not tamper with the electric system. Doing so may create a short, causing the fuse to trip.

**Our products are suitable for  
ASTM F963; GB6675; EN71 and EN62115 standard.**