

88449.130

14-08-2017

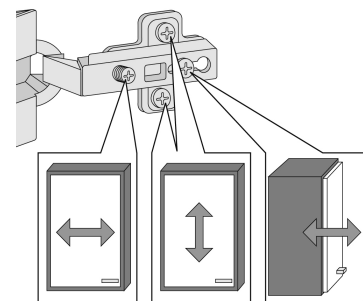

1	4 x 2802	2	4 x 2801	3	6 x 1606	4	6 x 1607	5	8 x 30 16 x 2861
6	5/5 x 16 24 x 2821	7	25 x 2862	8	3 x 1098	9	3,0 x 15 6 x 2803	10	4 x 30 4 x 2812
11	5,8 x 55 2 x 2840	12	8 x 30 2 x 2842	13	2 x 2843	14	6 x 2865	15	6,3 x 11 12 x 2815
16	1 x 2863								

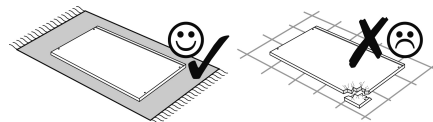
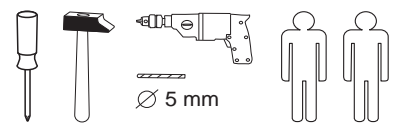
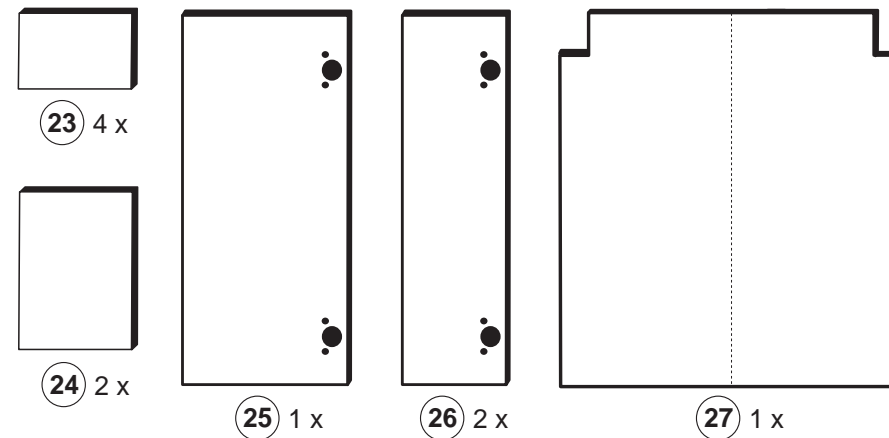
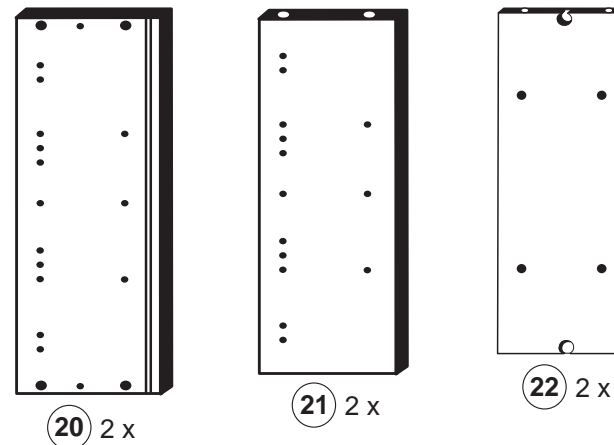
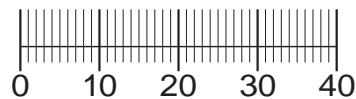

Das beigegefügte Wandbefestigungsmaterial (Dübel und Schrauben) eignet sich nur für festes Mauerwerk (z.B.: Beton- oder Ziegelwände). Für andere Wandaufbauten sind eventuell Spezialdübel und andere Schrauben notwendig. Ziehen Sie gegebenenfalls eine Fachkraft zu Rate.

De begeleidende wandmontage hardware (pluggen en schroeven) is alleen geschikt voor massief metselwerk (bijvoorbeeld beton of bakstenen muren). Voor andere muur structuren zijn eventueel bijzondere ankerbouten en andere noodzakelijke. Draai indien nodig, een deskundige.

Приложенный материал для крепления к стене (дюбели и винты) пригоден только для жестких кладок (например, бетонные или кирпичные стены). Для других настенных конструкций необходимы смотря по обстоятельствам специальные дюбели и другие винты. При необходимости проконсультируйтесь у специалиста.

Le mur d'accompagnement matériel de montage (chevilles et les vis) ne convient que pour la maçonnerie solide (par exemple en béton ou des murs de briques). Pour les structures de mur d'autres sont peut-etre spéciale boulons d'ancrage et d'autres nécessaires. Serrer le cas échéant, un expert.

Załączony materiał do mocowania do ściany (kolki rozprężne i wkręty) nadaje się tylko do ścian murowanych (np. z betonu lub cegieł). Do ścian wykonanych w innych technologiach konieczne być mogą specjalne kolki rozprężne i inne wkręty. W razie potrzeby skorzystaj z fachowej pomocy.

Il muro di accompagnamento hardware di montaggio (tasselli e viti) è e adatto solo per muratura piena (ad esempio calcestruzzo o muratura). Per le altre strutture murarie sono forse speciali bulloni di ancoraggio e necessari di altri. Serrare se necessario, un esperto.

The accompanying wall mounting hardware (anchors and screws) is suitable only for solid masonry (eg concrete or brick walls). For other wall structures are possibly special anchor bolts and other necessary. Tighten if necessary, an expert.

Ekteki duvara sabit montaj malzemeleri (dübel ve vidalar), sadece sağlam duvarlar için (örnek: beton veya tuğla) elverişlidir. Başka duvarlar için özel dübeller ve farklı vidalar gerekebilir. Gerektiğinde bir bilene danışınız.

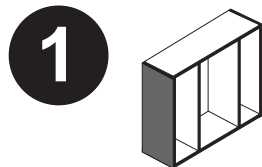

1	4 x 2802	6	8 x 2821
10	4 x 30 4 x 2812	13	2 x 2843

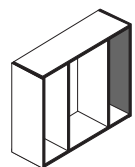
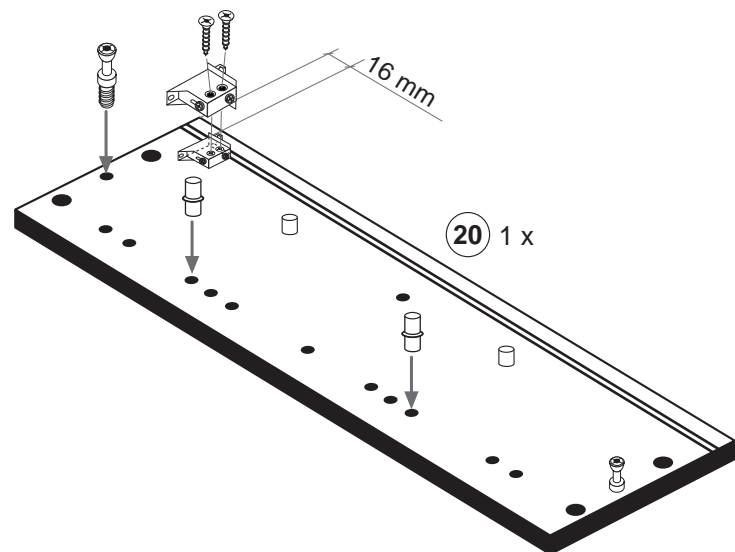

4	6 x 1607	5	8 x 30 8 x 2861
6	5/5 x 16 16 x 2821	16	1 x 2863

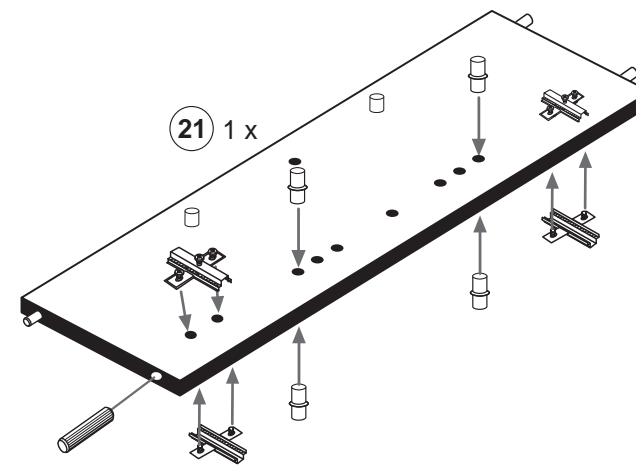
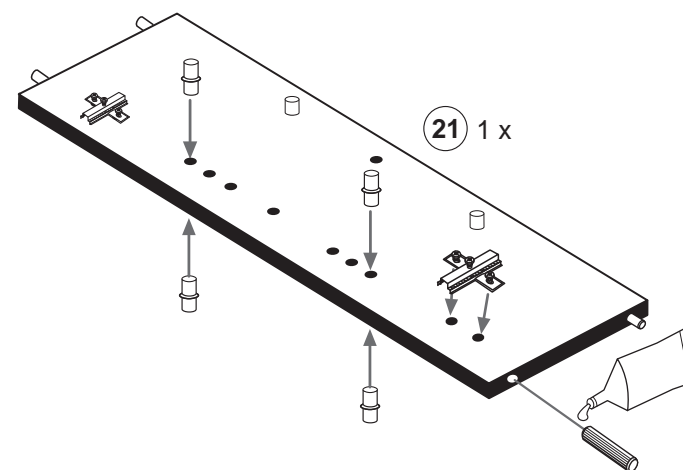

3

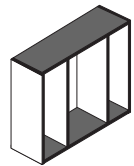

- 2** 4 x 2801
- 5** 8 x 30 2861
- 16** 1 x 2863

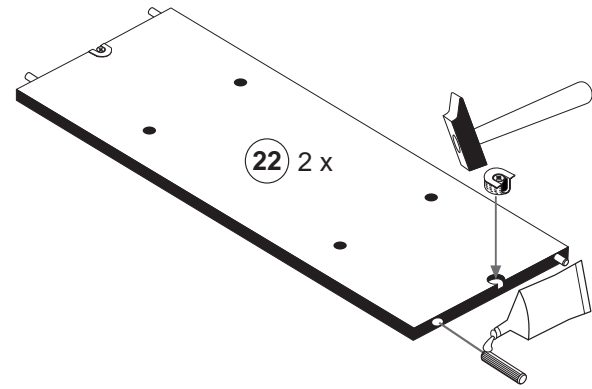

6

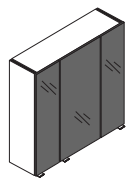

- 3** 6 x 1606
- 15** 6,3 x 11 12 x 2815

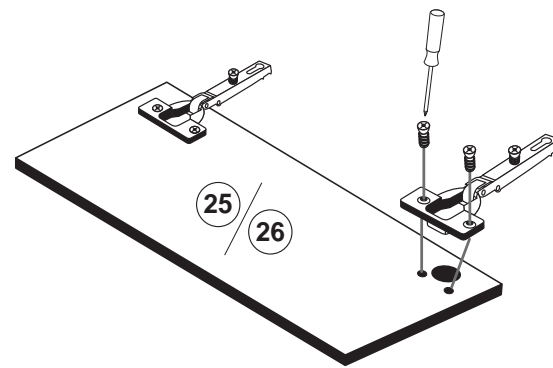

7

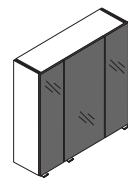

- 14** 6 x 2865

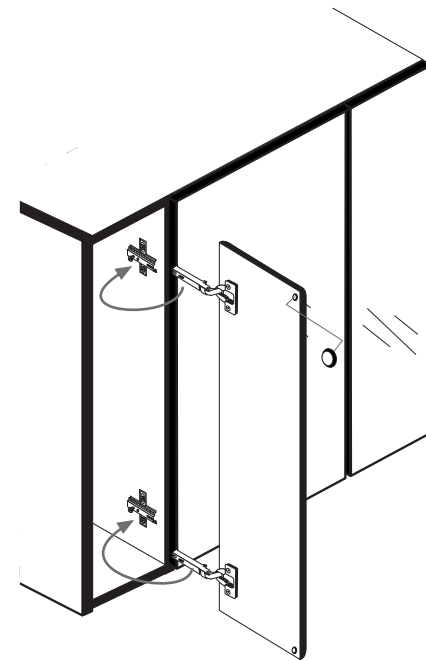

4

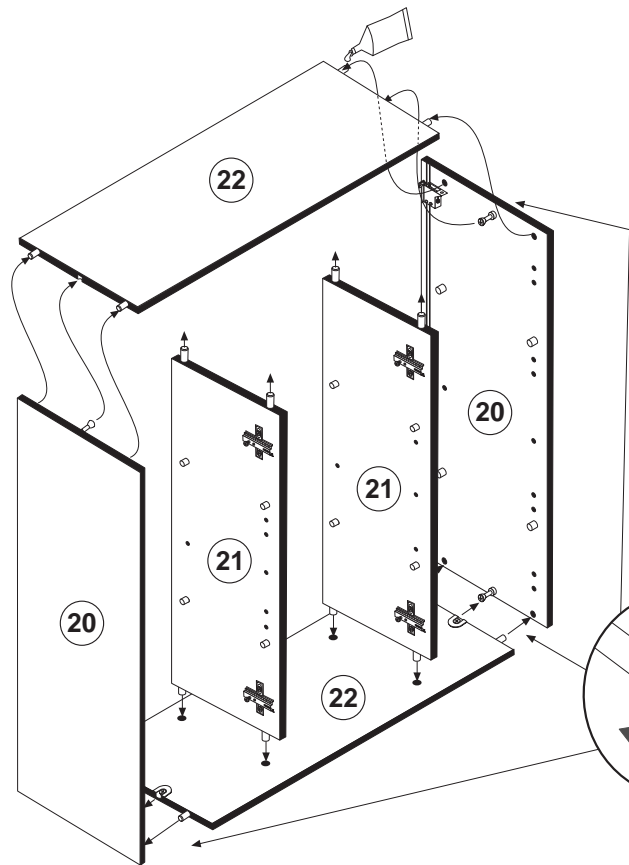

- 16** 1 x 2863
- 20 min.
- D Leim
GB Glue
NL Lijm
PL Klej
TR Tutkal
F Colle
I Colla

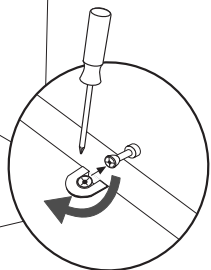

8

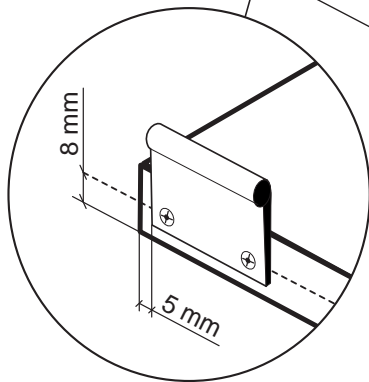
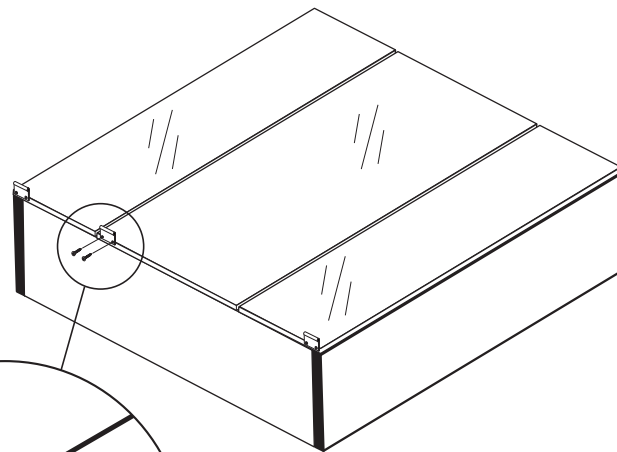

- 17** 3 x 1098
- 19** 3,0 x 15 6 x 2803

9

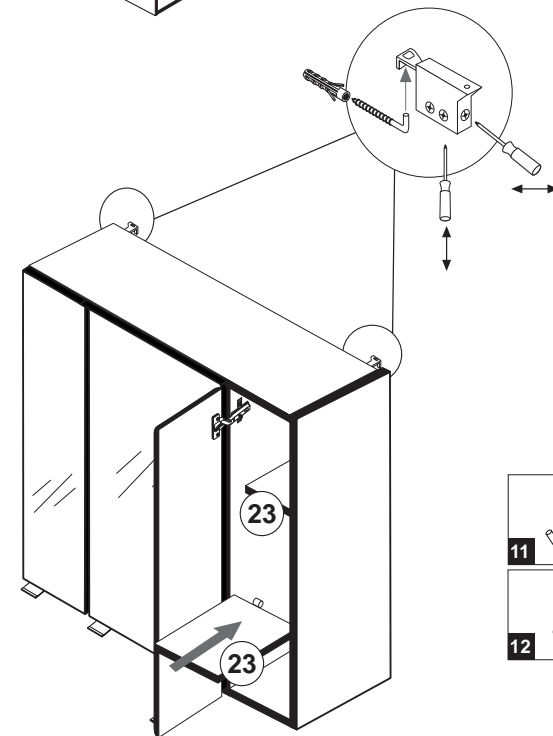
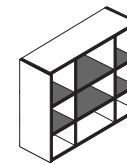

- 11** 5,8 x 55 2 x 2840
- 12** 8 x 30 2 x 2842

5

- 7** 25 x 2862

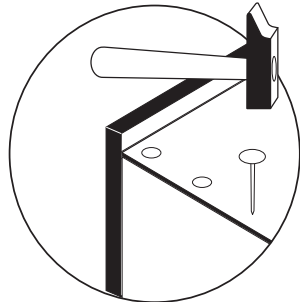
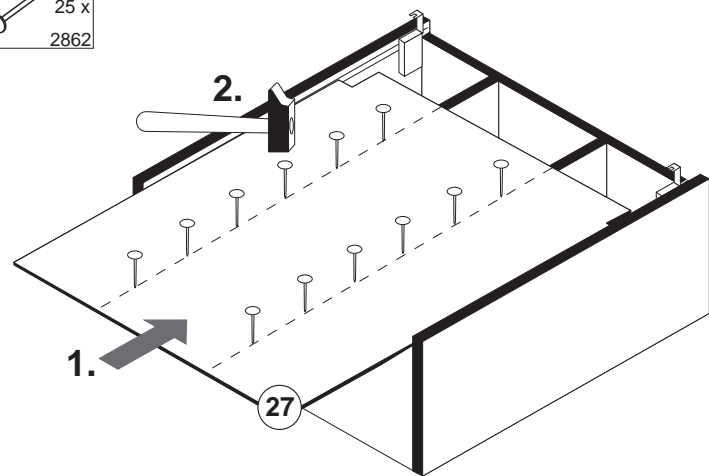

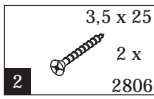
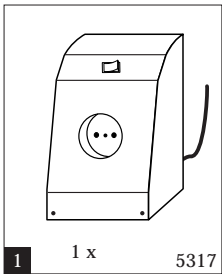
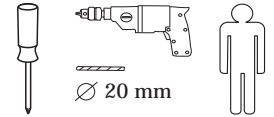

Die Montageposition der Schalterbox ist am Unterboden des Spiegelschranks frei wählbar.
Bohren Sie an der gewünschten Montageposition wie abgebildet ein Loch für das Kabel in die Rückwand. (Durchmesser 20mm)

1

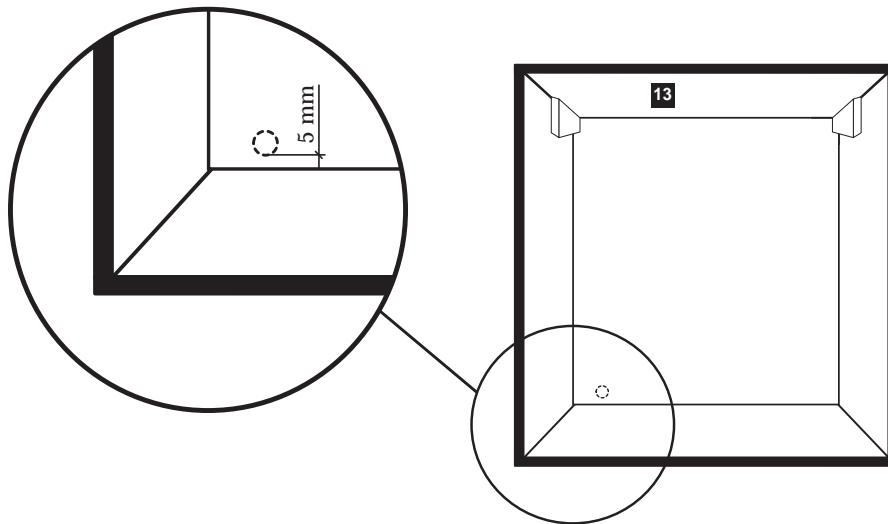

2

1. Führen Sie die Kabel durch die Bohrung in der Rückwand.
2. Montieren Sie die geöffnete Schalterbox wie abgebildet mit der Hinterkante bündig an der Rückwand.
3. Schieben Sie die Frontabdeckung der Schalterbox nach hinten bis diese "einrastet".

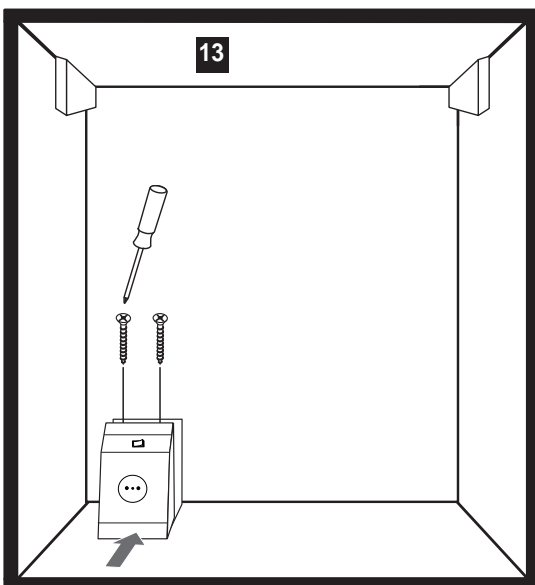



D



Wichtige Sicherheitshinweise

Die Installation Ihrer neuen Leuchte darf ausschließlich von autorisierten Fachpersonen durchgeführt werden

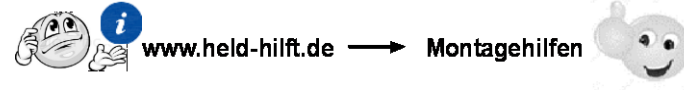

GB



Important safety instructions

The installation of your new luminaire may only be carried out by authorized specialists.

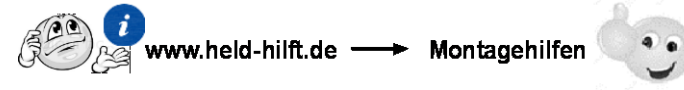

FR



Consignes de sécurité importantes

La L'installation votre nouveau luminaire doit uniquement être réalisée par des spécialistes autorisés

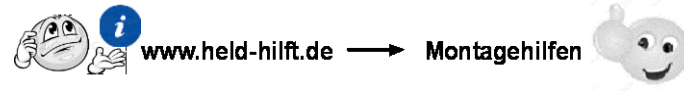

IT



Importanti disposizioni di sicurezza

L'installazione della il loro nuovo lampada può essere eseguita solo ed esclusivamente da personale tecnico autorizzato.

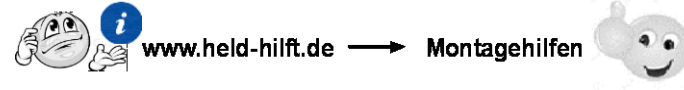

NL



Belangrijke veiligheidsaanwijzingen

De installatie van de nieuwe lamp moet worden uitgevoerd door vakbekwame personen worden uitgevoerd.

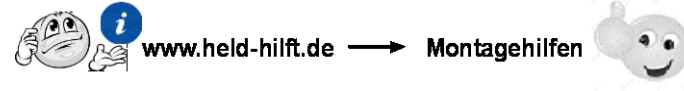

CZ



Důležité bezpečnostní pokyny

Instalaci nových svítidel smí provádět pouze kvalifikovaný elektrikář.

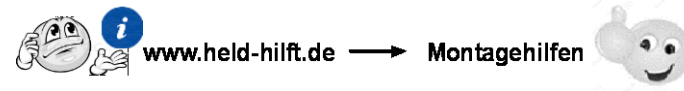

PL



Ważne wskazówki dotyczące bezpieczeństwa

Ta Instalację nowej lampy mogą przeprowadzać wyłącznie autoryzowani instalatorzy

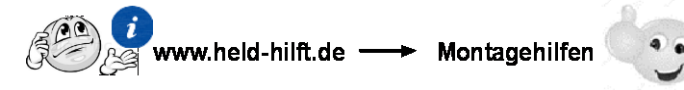

SK



Dôležité bezpečnostné upozornenia

Inštaláciu lampy smú vykonať výhradne autorizovaní



HU



Fontos biztonsági utmutatások

Az On Új lámpájának beszerelését kizárólag hivatalos szakember végezheti el



RO



Instrucțiuni de siguranță importante

Instalarea noii dumneavoastră lămpi este permisă exclusiv specialiștilor autorizați



TR



Önemli güvenlik uyarıları

Yeni lamba montajı yetkin kişiler tarafından yapılmalıdır

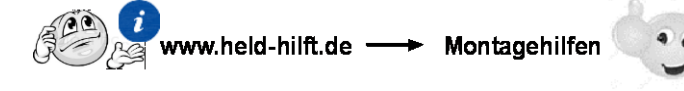

RU



важная информация по технике безопасности

Установка вашей новой лампы должна выполняться квалифицированным персоналом



89904.330

**D****Wichtige Pflegehinweise**

Bitte beachten Sie die wichtigen Pflegehinweise auf unserer Internetseite



www.held-hilft.de



Pflegehinweise

**PL****Ważne instrukcje dotyczące pielęgnacji**

Zwróć uwagę na ważną instrukcję dotyczącą pielęgnacji na naszej stronie internetowej



www.held-hilft.de



Pflegehinweise

**GB****Important care instructions**

Please note the important care instructions on our website



www.held-hilft.de



Pflegehinweise

**SK****Dôležité pokyny na starostlivosť**

Dbajte na dôležité pokyny týkajúce sa starostlivosti na našich webových stránkach



www.held-hilft.de



Pflegehinweise

**FR****Instructions d'entretien importantes**

S'il vous plaît noter les instructions de soins importants sur notre site Web



www.held-hilft.de



Pflegehinweise

**HU****Fontos kezelési utasítások**

Kérjük, vegye figyelembe a honlapunkon található fontos kezelési útmutatót



www.held-hilft.de



Pflegehinweise

**IT****Importanti istruzioni per la cura**

Si prega di notare le importanti istruzioni per la cura sul nostro sito web



www.held-hilft.de



Pflegehinweise

**RO****Instrucțiunile importante de îngrijire**

Rețineți instrucțiunile importante de îngrijire de pe site-ul nostru



www.held-hilft.de



Pflegehinweise

**NL****Belangrijke zorginstructies**

Let op de belangrijke zorginstructies op onze website



www.held-hilft.de



Pflegehinweise

**TR****Önemli bakım talimatları**

Lütfen web sitemizdeki önemli bakım talimatlarını dikkate alınız



www.held-hilft.de



Pflegehinweise

**CZ****Důležité pokyny pro péči**

Vezměte prosím na vědomí důležité pokyny pro péči na našich webových stránkách



www.held-hilft.de



Pflegehinweise

**RU****Важные инструкции по уходу**

Обратите внимание на важные инструкции по уходу на нашем веб-сайте



www.held-hilft.de



Pflegehinweise



88844.311

20-04-2017

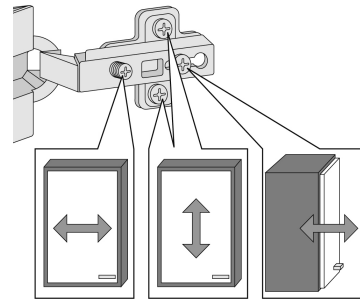
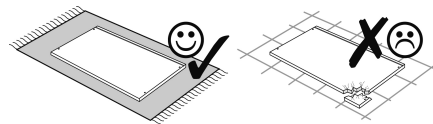
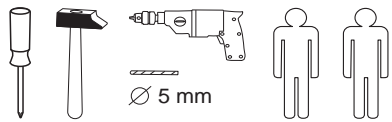

1 4 x 2802	2 4 x 2801	3 8 x 2815	4 28 x 2804	5 12 x 2861	6 2 x 2855
7 1 x 2863	8 2 x 2863	9 4 x 22/25 4 x 2815	10 4 x 2865	11 4 x 1121	12 8 x 2816
13 2 x 2840	14 2 x 2842	15 1 x 2881	16 1 x 2880	17 2 x 2830	18 4 x 1122
19 2 x 5285.400	20 2 x 5284.400	Silikon 25ml 21 1 x 1970			

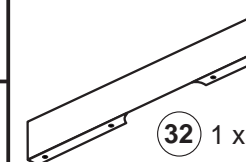
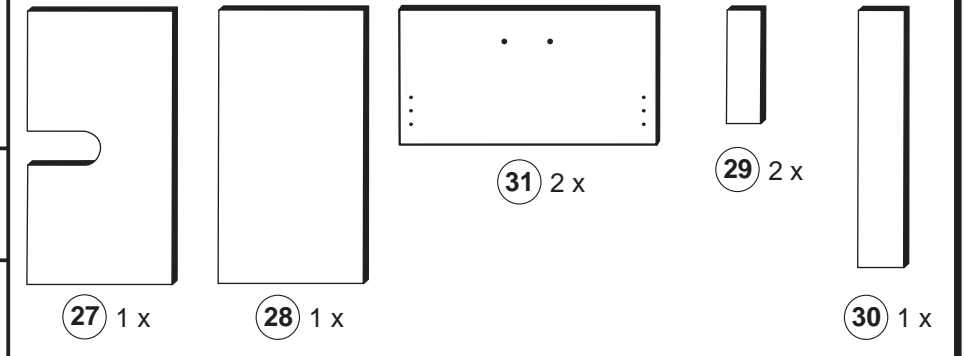
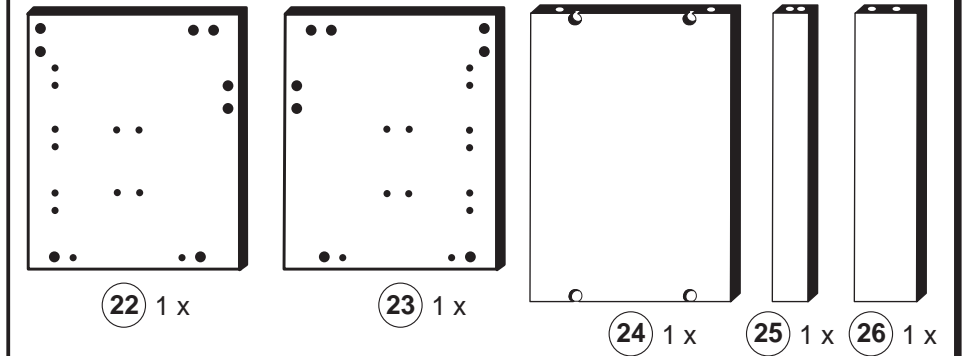
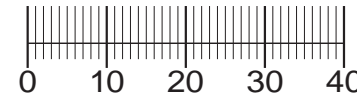

Das beigegefügte Wandbefestigungsmaterial (Dübel und Schrauben) eignet sich nur für festes Mauerwerk (z.B.: Beton- oder Ziegelwände). Für andere Wandaufbauten sind eventuell Spezialdübel und andere Schrauben notwendig. Ziehen Sie gegebenenfalls eine Fachkraft zu Rate.

De beigeleidende wandmontage hardware (pluggen en schroeven) is alleen geschikt voor massief metselwerk (bijvoorbeeld beton of bakstenen muren). Voor andere muur structuren zijn eventueel bijzondere ankerbouten en andere noodzakelijke. Draai indien nodig, een deskundige.

Приложенный материал для крепления к стене (дюбели и винты) пригоден только для жестких кладок (например, бетонные или кирпичные стены). Для других настенных конструкций необходимы смотря по обстоятельствам специальные дюбели и другие винты. При необходимости проконсультируйтесь у специалиста.

Le mur d'accompagnement matériel de montage (chevilles et les vis) ne convient que pour la maçonnerie solide (par exemple en béton ou des murs de briques). Pour les structures de mur d'autres sont peut-être spéciale boulons d'ancrage et d'autres nécessaires. Serrer le cas échéant, un expert.

Załączony materiał do mocowania do ściany (kolki rozprężne i wkręty) nadaje się tylko do ścian murowanych (np. z betonu lub cegiel). Do ścian wykonanych w innych technologiach konieczne być mogą specjalne kolki rozprężne i inne wkręty. W razie potrzeby skorzystaj z fachowej pomocy.

Il muro di accompagnamento hardware di montaggio (tasselli e viti) è adatto solo per muratura piena (ad esempio calcestruzzo o muratura). Per le altre strutture murarie sono forse speciali bulloni di ancoraggio e necessari di altri. Serrare se necessario, un esperto.

The accompanying wall mounting hardware (anchors and screws) is suitable only for solid masonry (eg concrete or brick walls). For other wall structures are possibly special anchor bolts and other necessary. Tighten if necessary, an expert.

Ekteki duvara sabit montaj malzemeleri (dübel ve vidalar), sadece sağlam duvarlar için (örnek: beton veya tuğla) elverişlidir. Başka duvarlar için özel dübeller ve farklı vidalar gerekebilir. Gerektiğinde bir bilene danışınız.

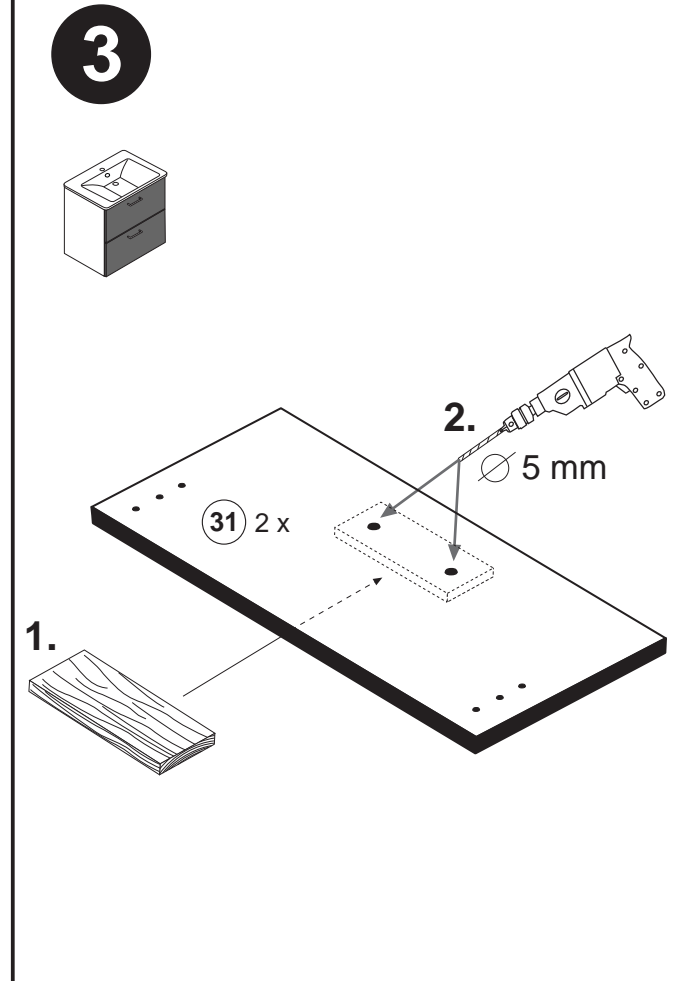
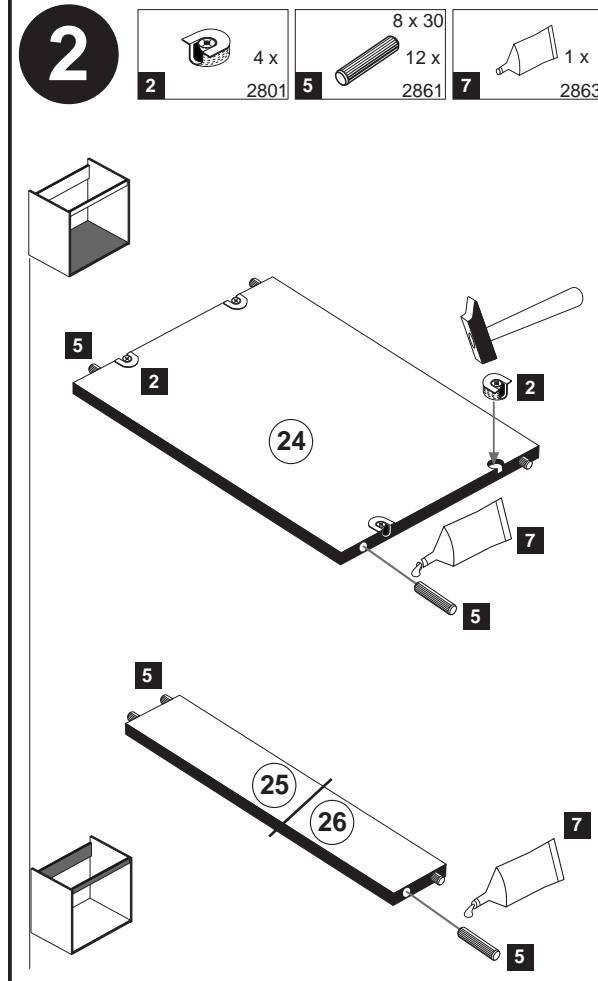
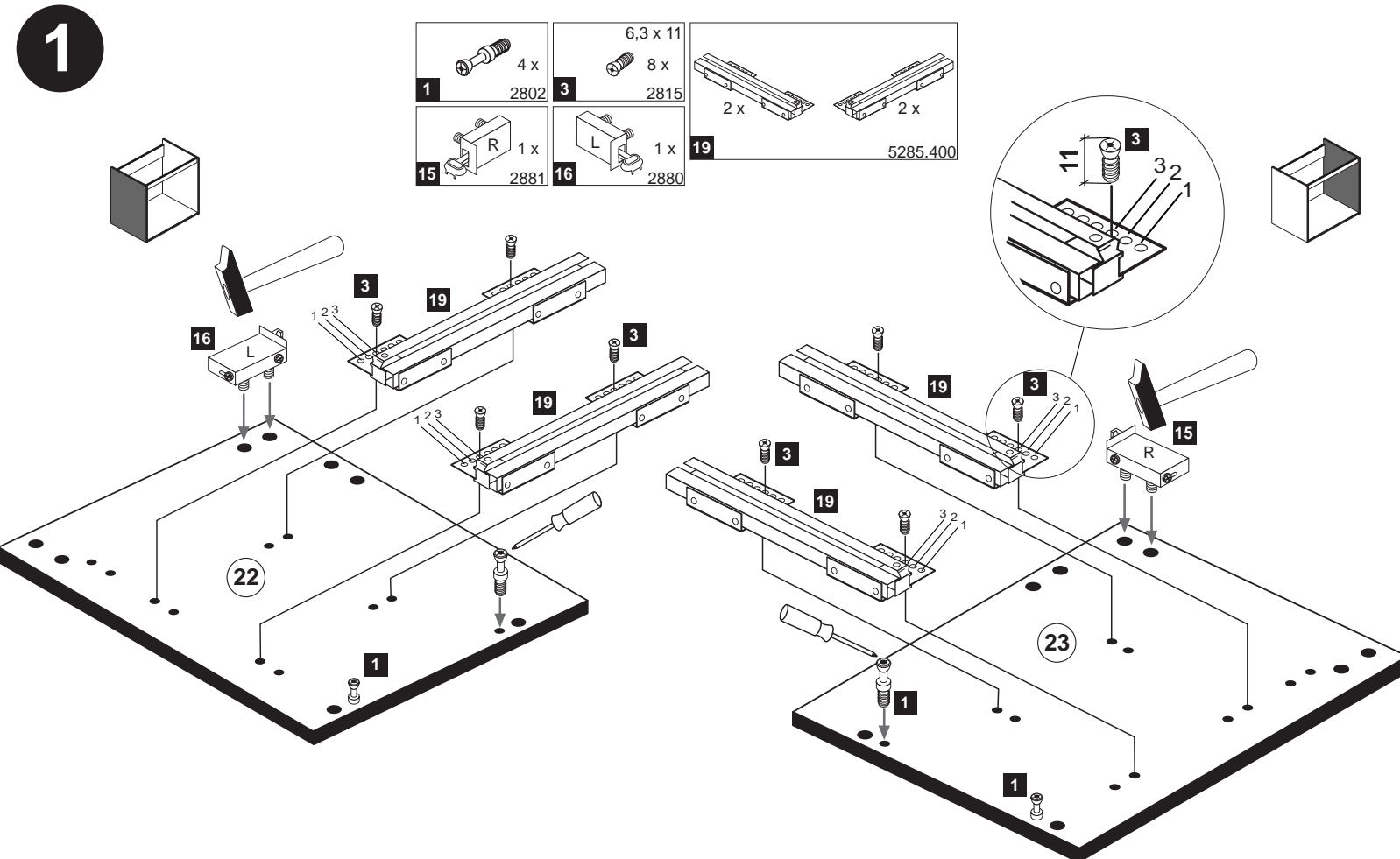

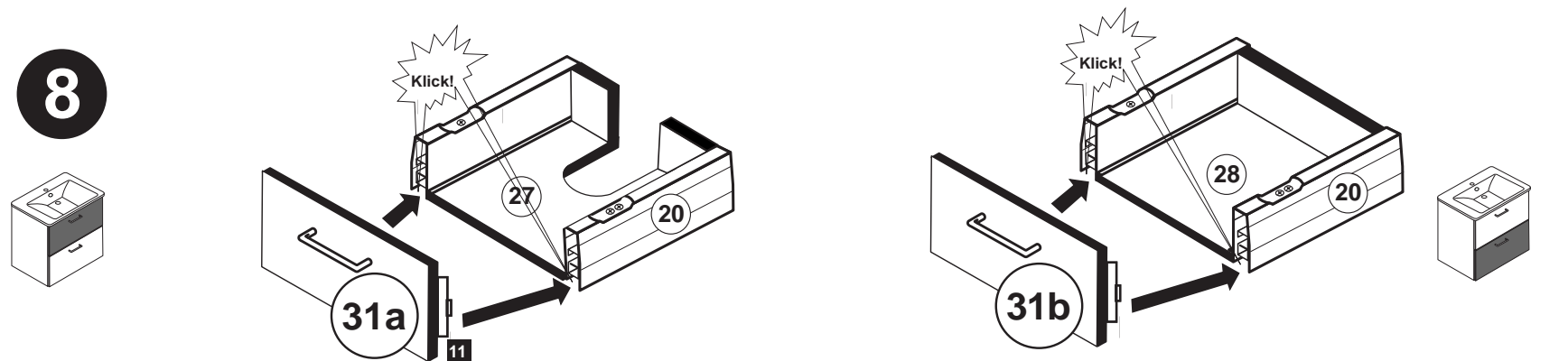
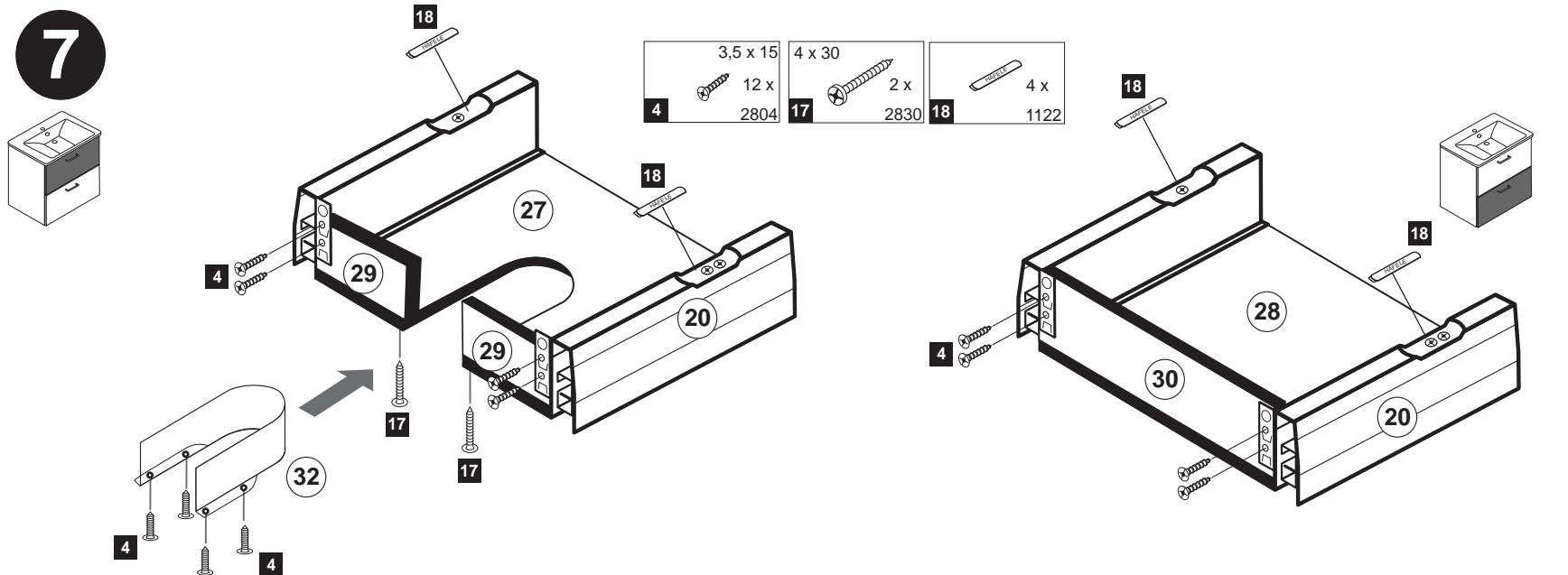
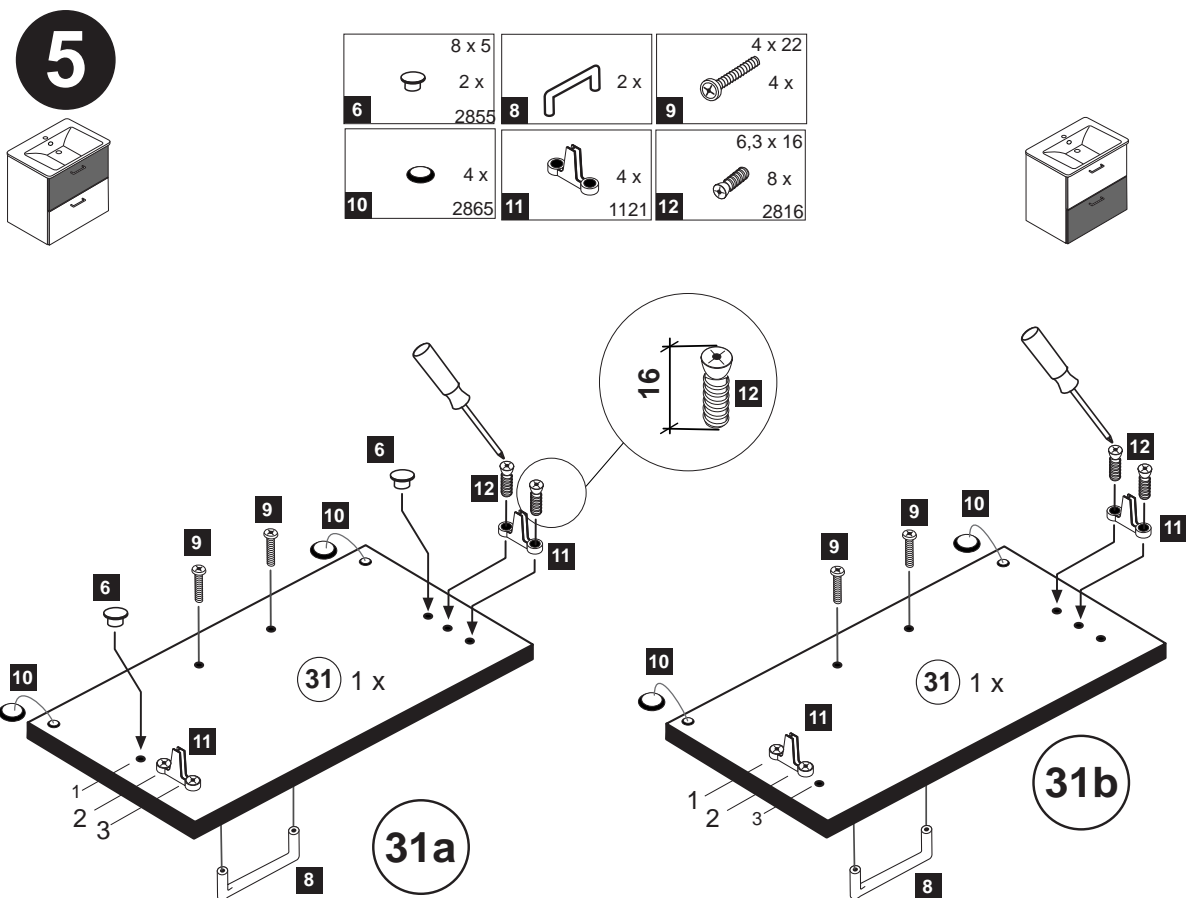
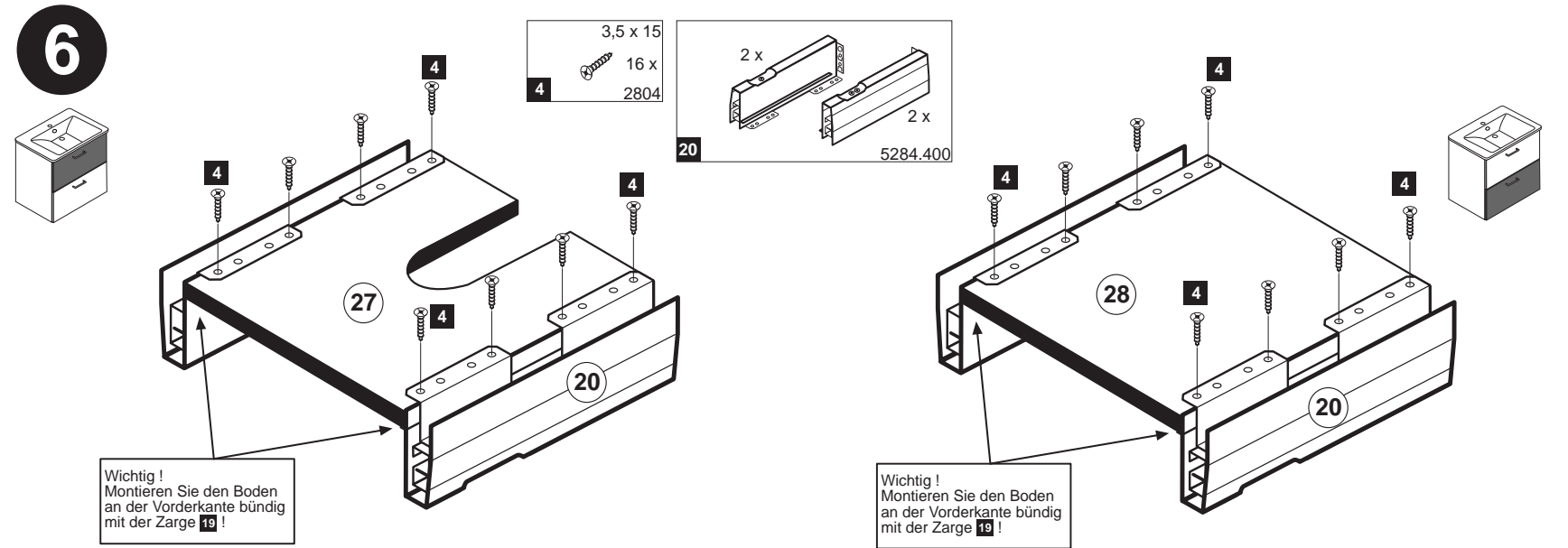
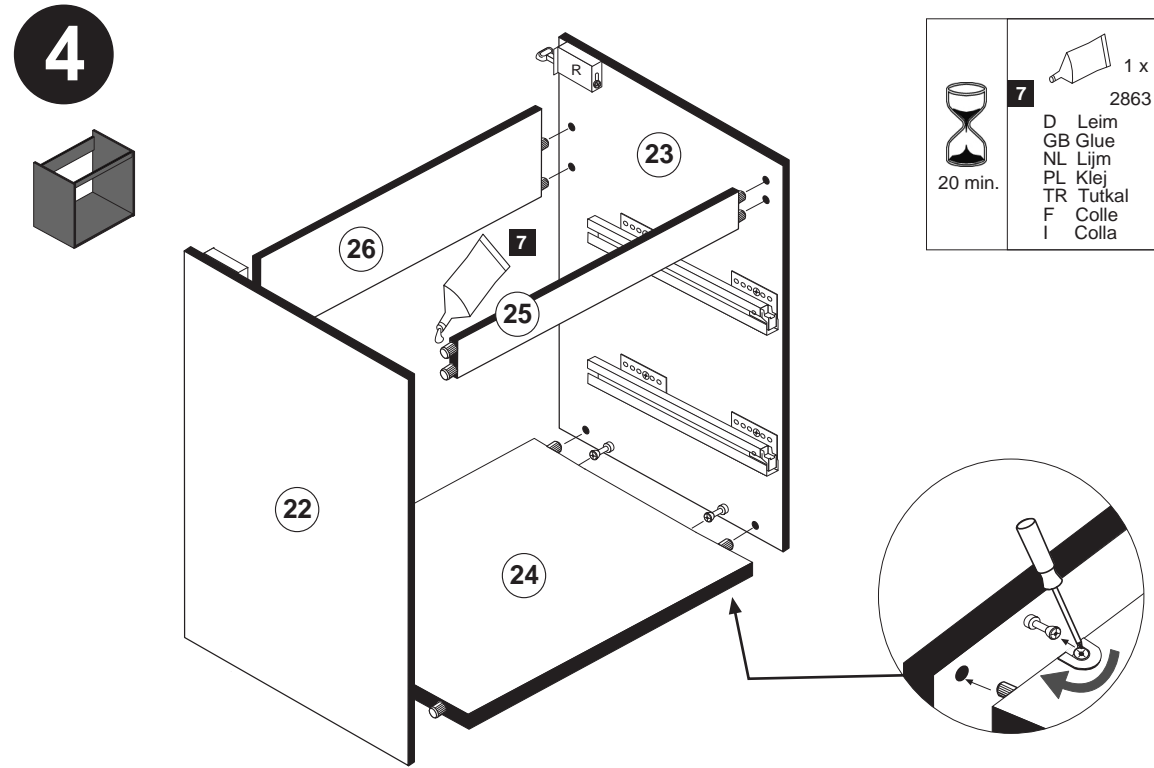

Hinweis!
 Wie Sie den Schubkasten einhängen müssen entnehmen Sie bitte dem beigefügten Montagezettel der Firma HÄFELE.
 Zusätzlich finden Sie auf dem Montagezettel folgende Abbildungen und Montagehilfen:

- Montage der Abdeckkappe 13
- Einstellen der Schubkastenblende
- Aushängen des Schubkastens
- Abnehmen der Schubkastenblende

9

5,8 x 55	8 x 30
2 x	2 x
13 2840	14 2842

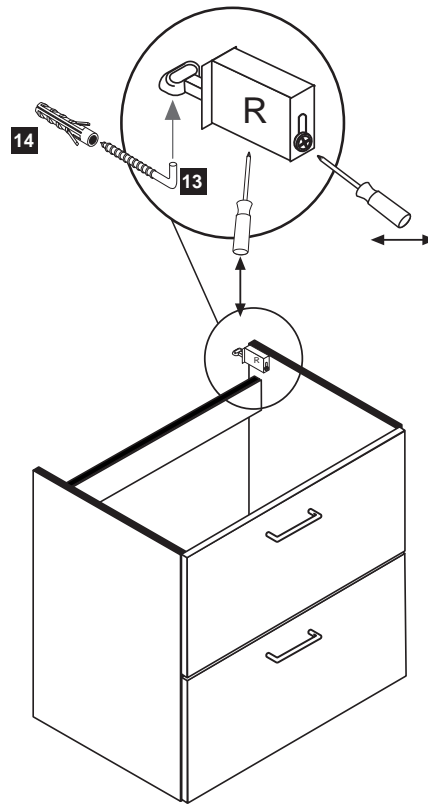

10

Silikon 25ml	1 x
21 1970	

Waschbeckenmontage

1. Silikon auf Stirnkante der Seiten auftragen
2. Waschbecken auflegen
3. Fuge zwischen Waschbecken und Wand mit Silikon abdichten
4. Seitliche Fugen zwischen Waschbecken und Unterschrank mit Silikon abdichten

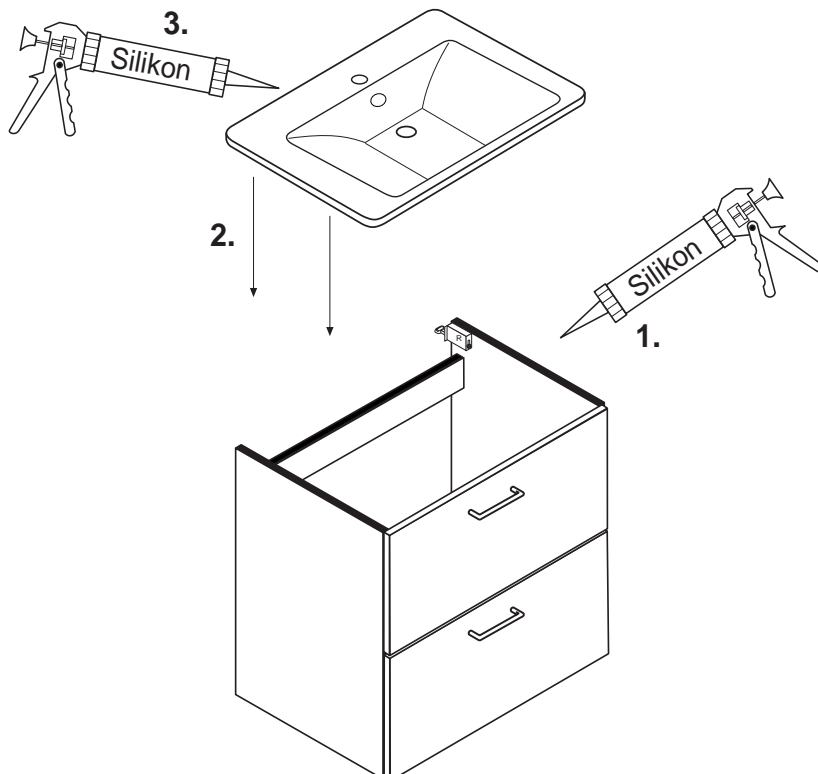

4

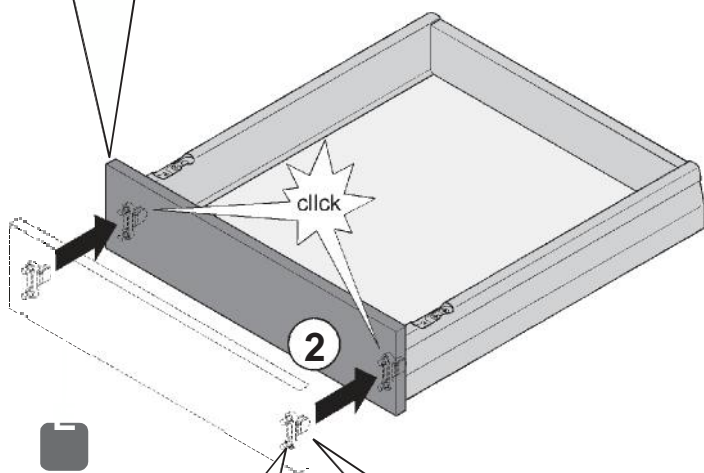
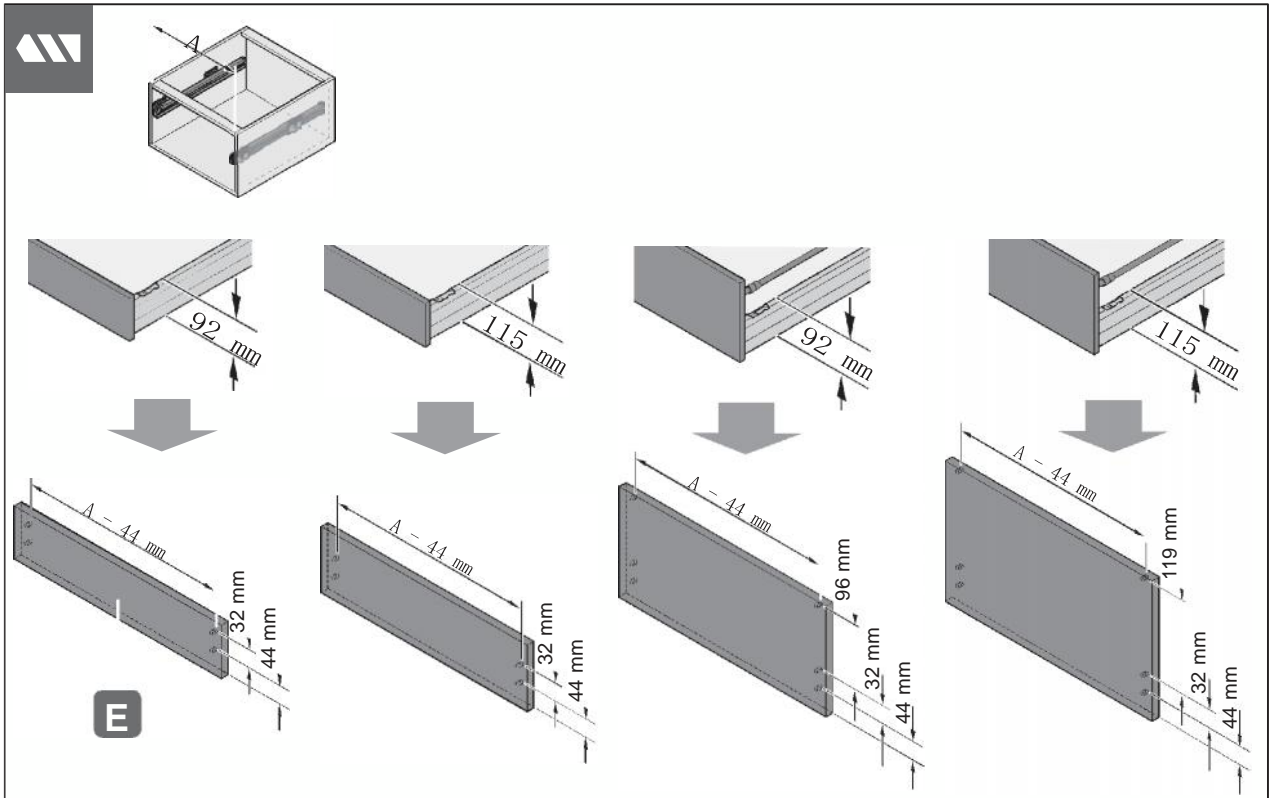

Variante
Version
Versión
Versione

A

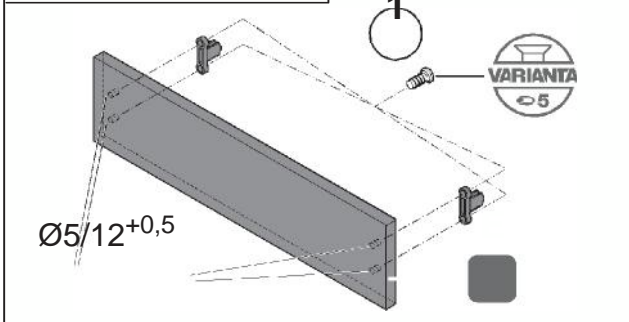

Variante
Version
Versión
Versione

B

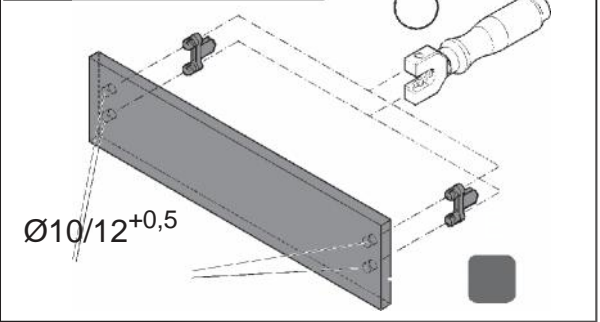

Maße in mm – Dimensions in mm – Medidas en mm – Misure in mm

HDE 10.11.09



5

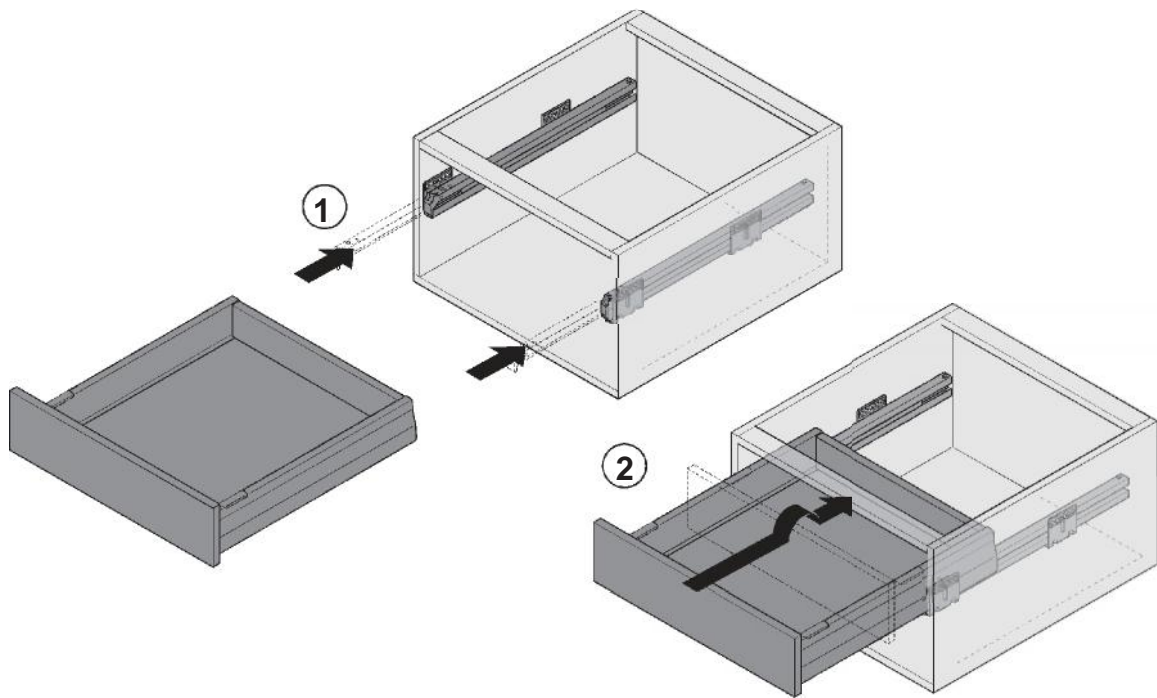

Einstellung

En
Fr
Es
It

HDE 10.11.09 Maße in mm – Dimensions in mm – Medidas en mm – Misure in mm

