

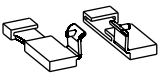











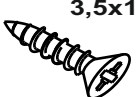
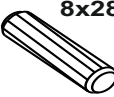

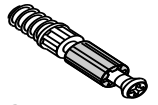

 4x L+P <b>P05</b>	 4x L+P. <b>B12</b>	 6x11 <b>W12</b>	 L-306 6x <b>U24</b>	 4x25 12x <b>W05</b>	 6x <b>S03</b>	 3,5x16 20x <b>W30</b>	 8x28 32x <b>D01</b>	 7x50 8x <b>W04</b>	 1x <b>K01</b>		
 15x12 8x <b>T02</b>	 12x9,5 8x <b>T12</b>	 16x <b>T01</b>	 6,3x40 16x <b>D02</b>	 12x <b>C01</b>	 KR-0 4x <b>Z02</b>	 4x <b>Z04</b>	 8x <b>E01</b>	 26x <b>R01</b>	 2x <b>P01</b>		
 4x13 4x <b>W07</b>	 2x <b>F01</b>	 2x <b>F11</b>									

NR	DIM	QTE	COLLI
1	845x362x15	1	1/2
2	845x362x15	1	1/2
3	845x362x15	1	2/2
4	845x362x15	1	2/2
5	1501x380x22	1	2/2
6	1501x380x22	1	2/2
7	427x333x15	2	2/2
8	840x450x15	1	1/2
9	840x450x15	1	1/2
10	860x441x2	2	1/2
11	860x295x2	2	1/2
12	590x208x15	4	1/2
13	300x120x12	4	1/2
14	300x120x12	4	1/2
15	543x120x12	4	1/2
16	554x300x2	4	1/2



0 10 20 30 40 50 60 70 80 90 100 110 120 130 140 150 160 170 180 190 200

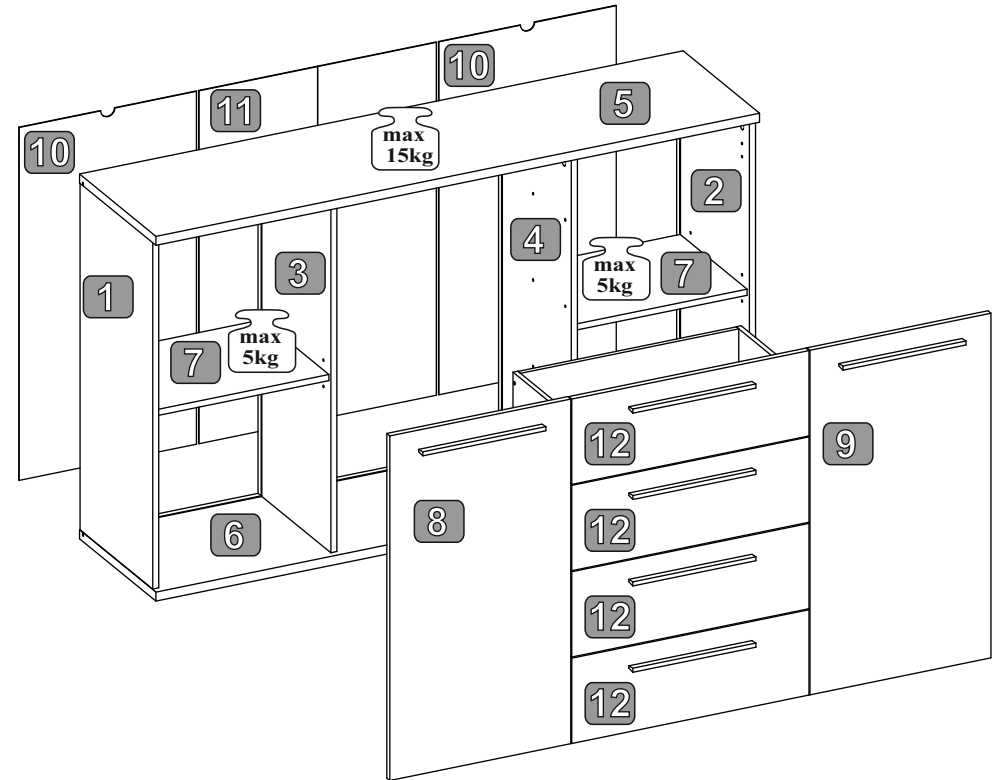
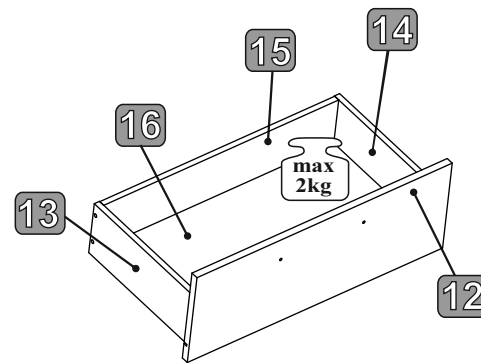

1 (x4)

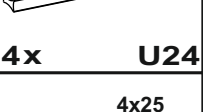
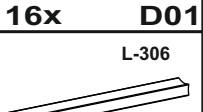
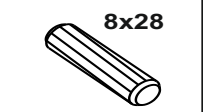
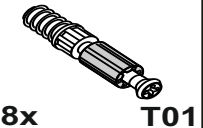
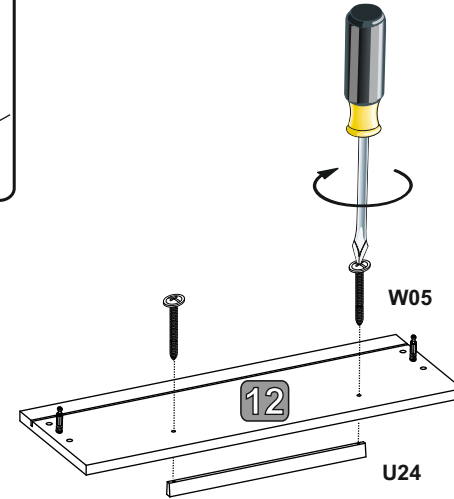
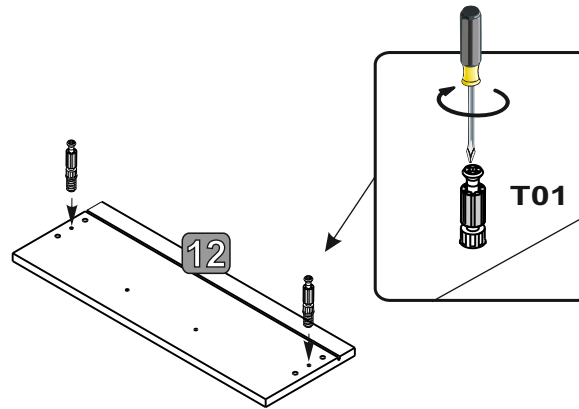
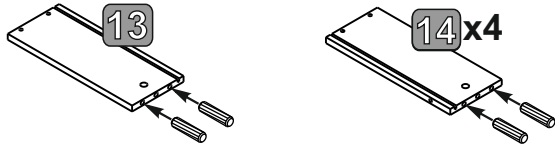

2 (x4)

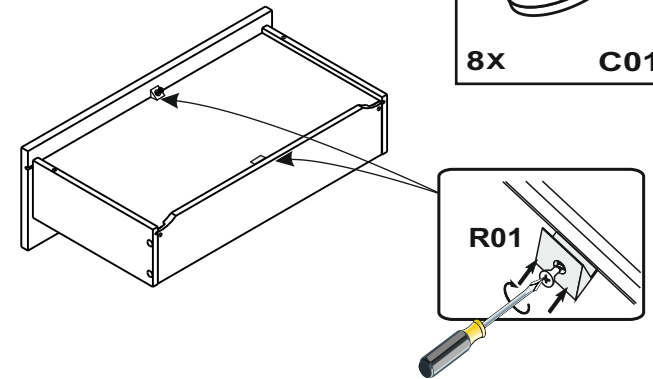
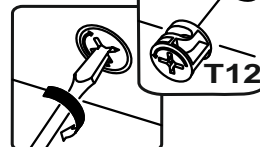
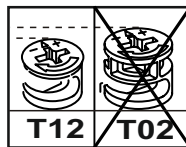
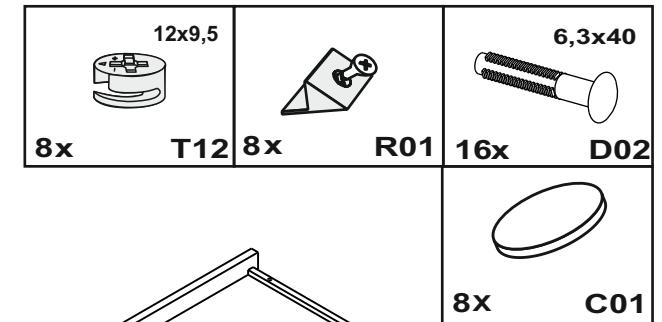
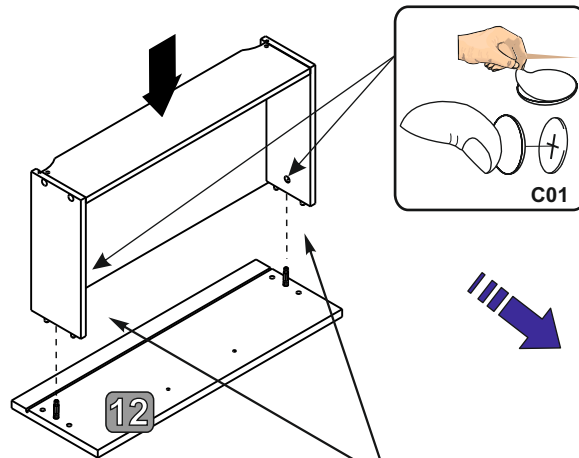
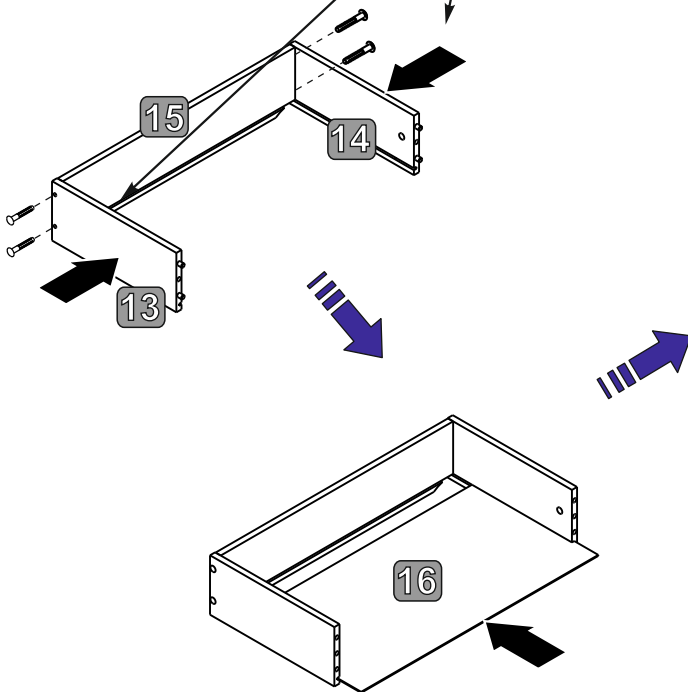
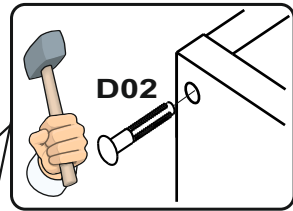

3

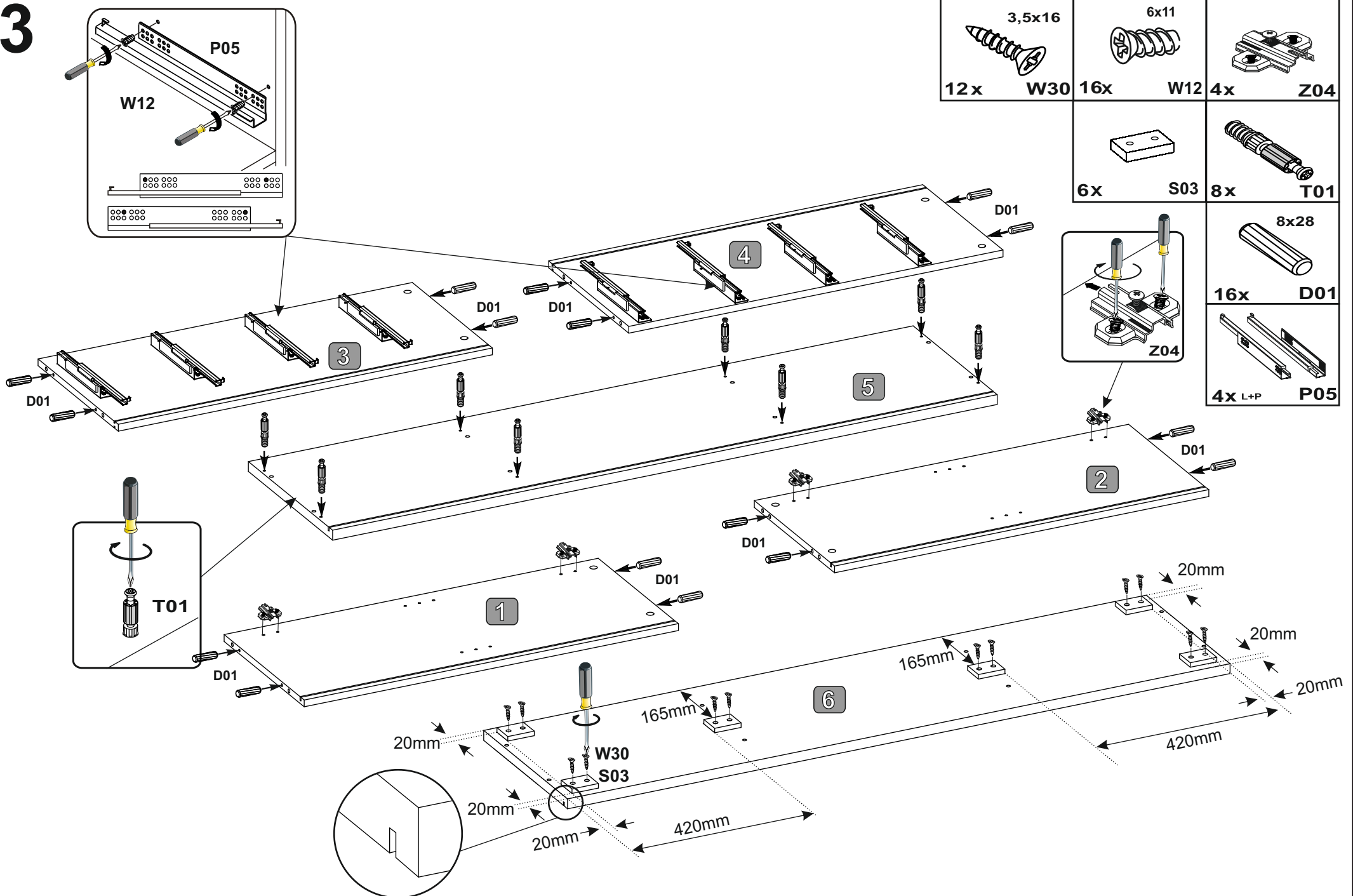

4

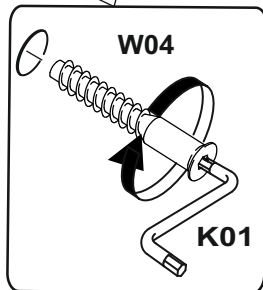
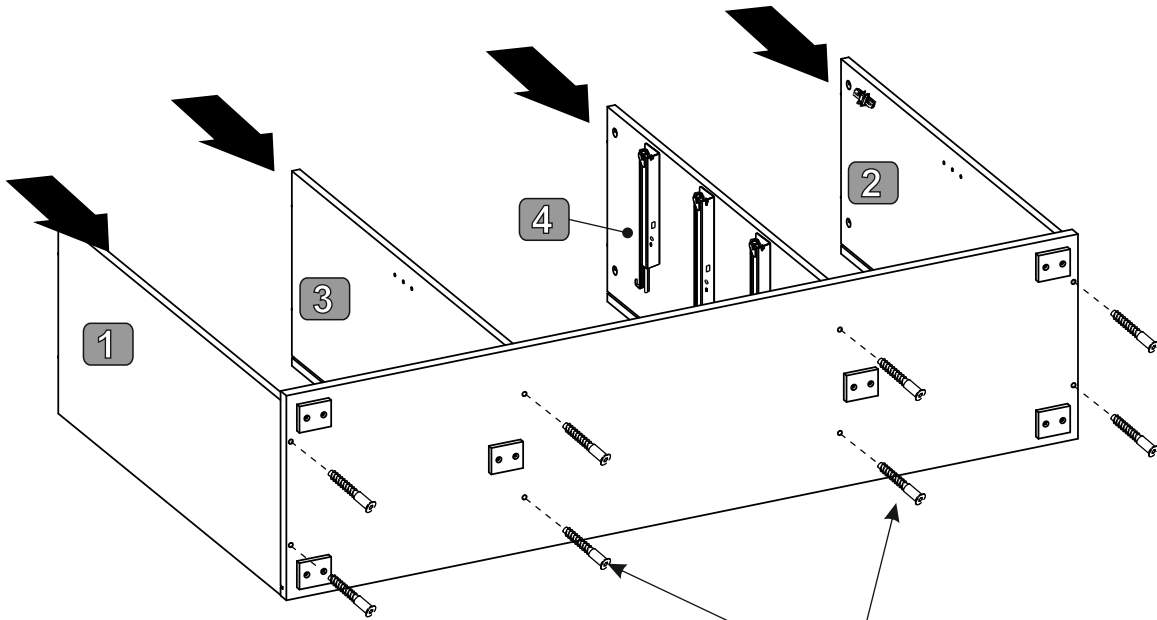
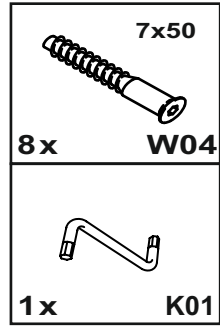

5

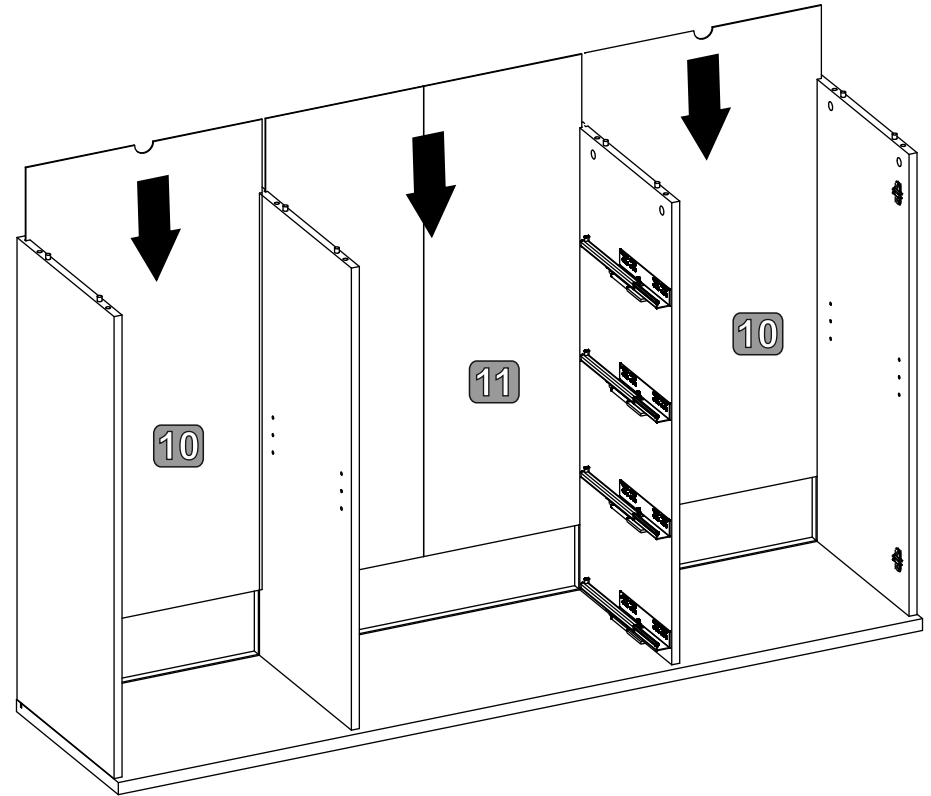

6

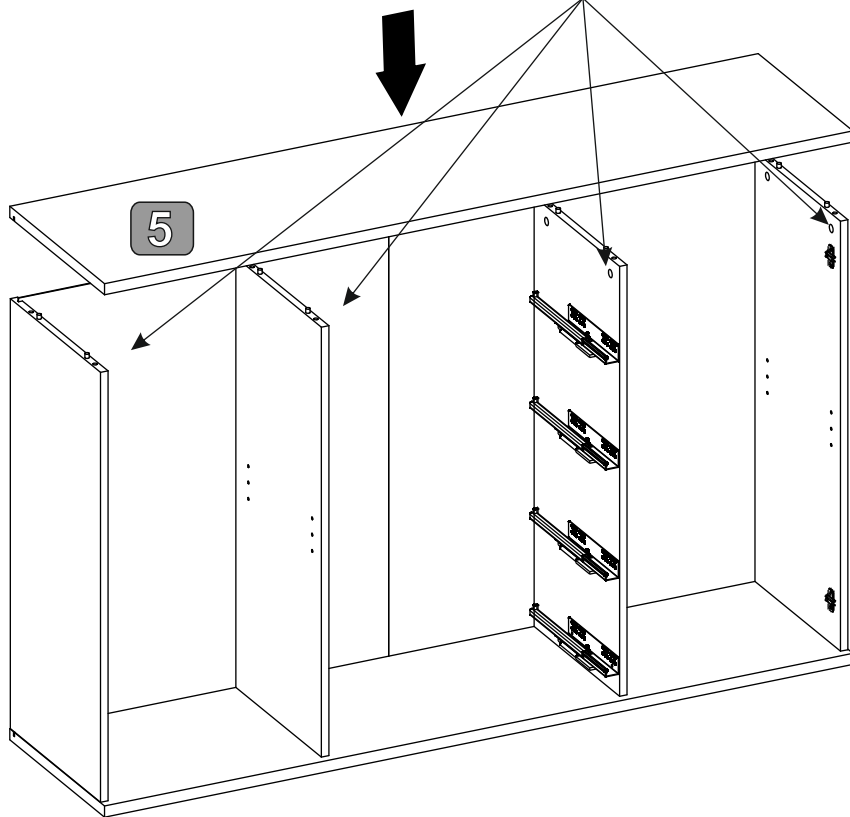
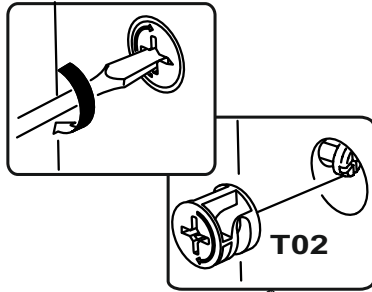
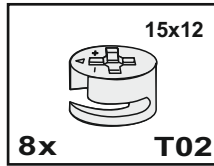

7

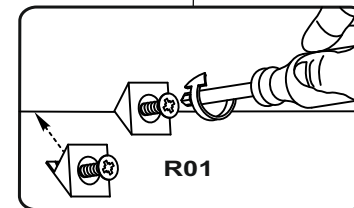
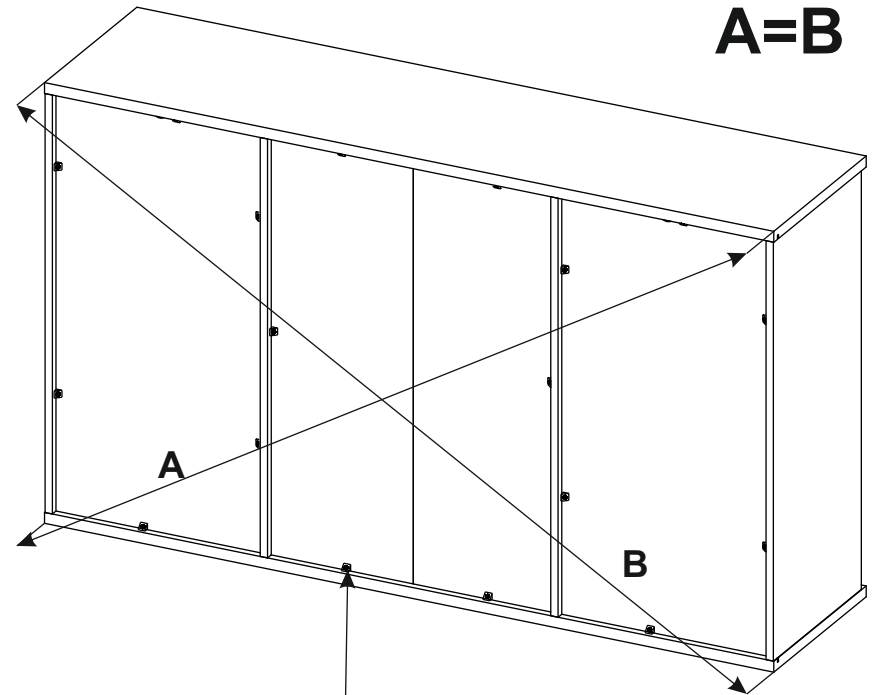
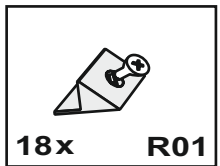

## 8

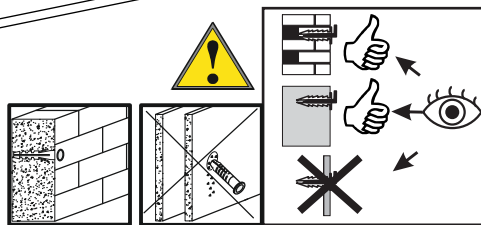
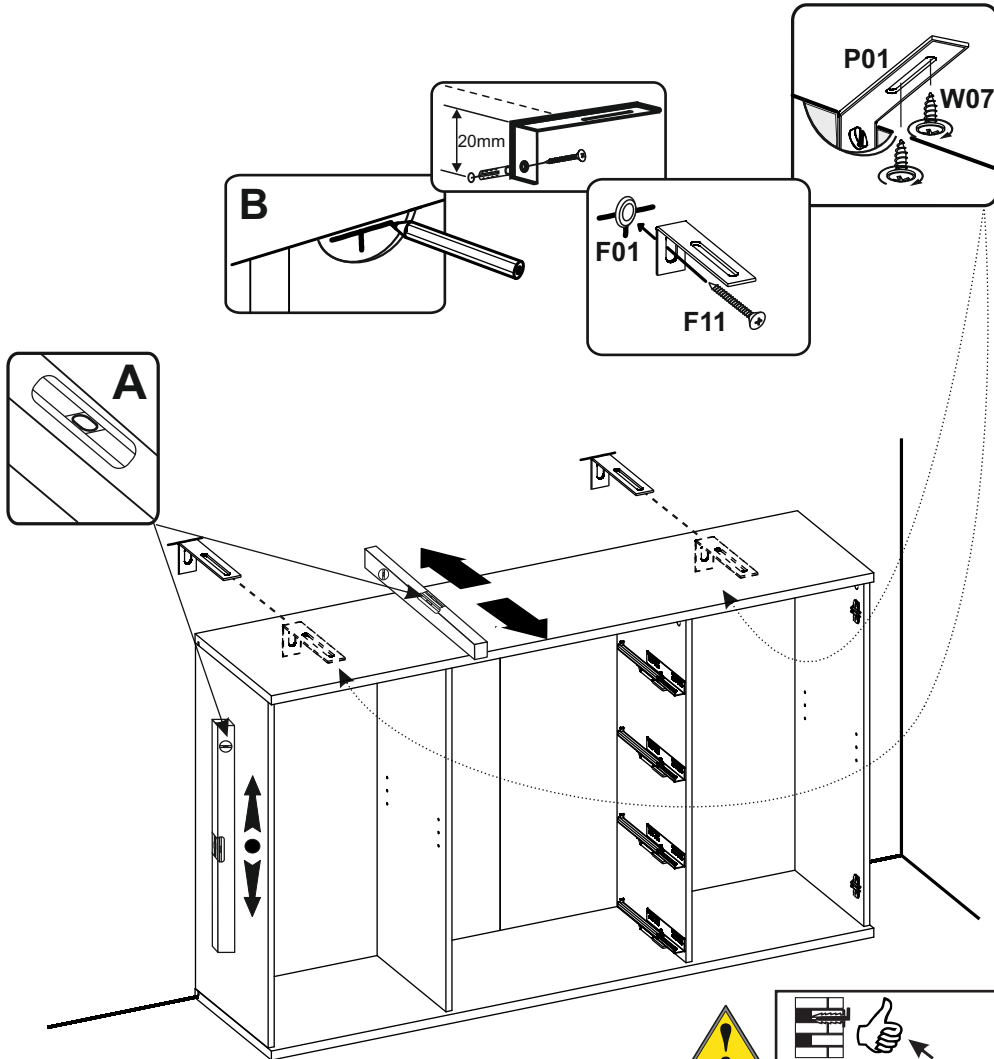
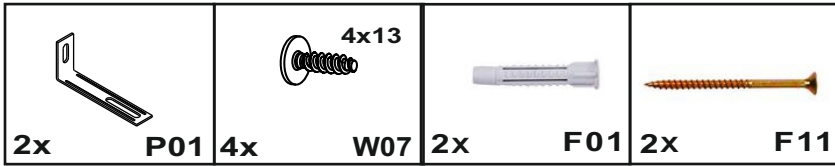

## 9

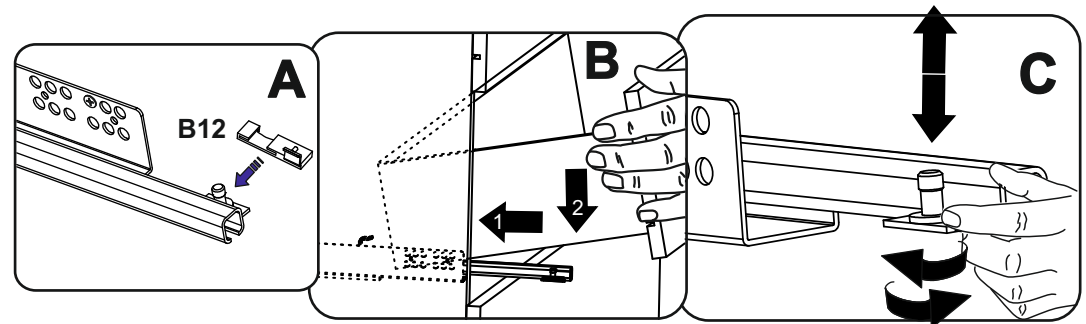
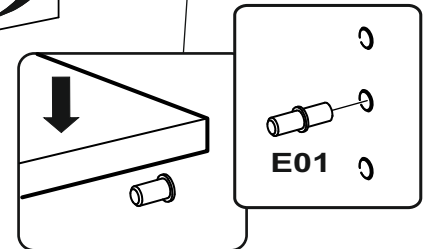
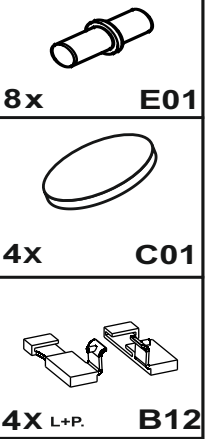
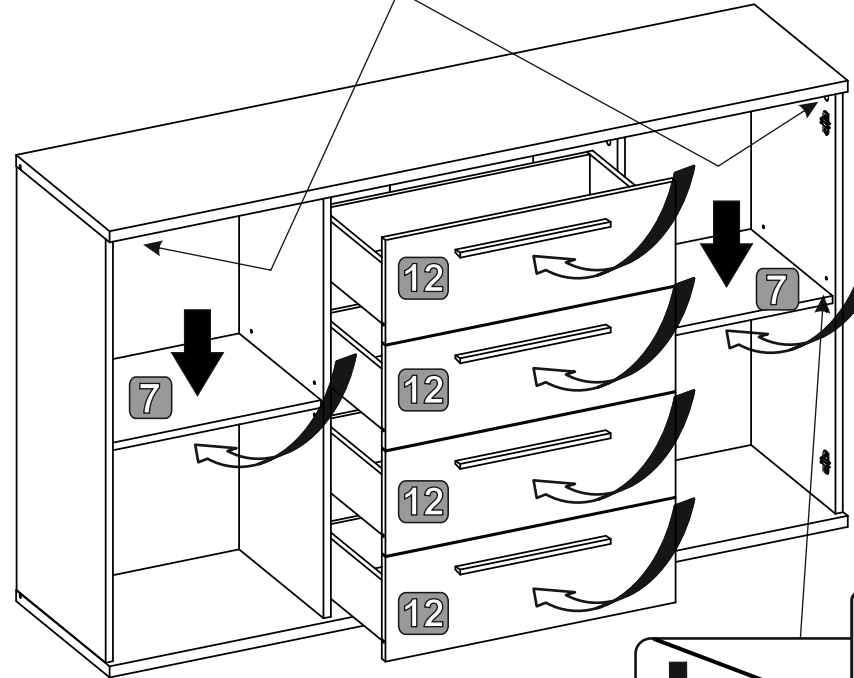
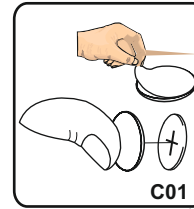

10

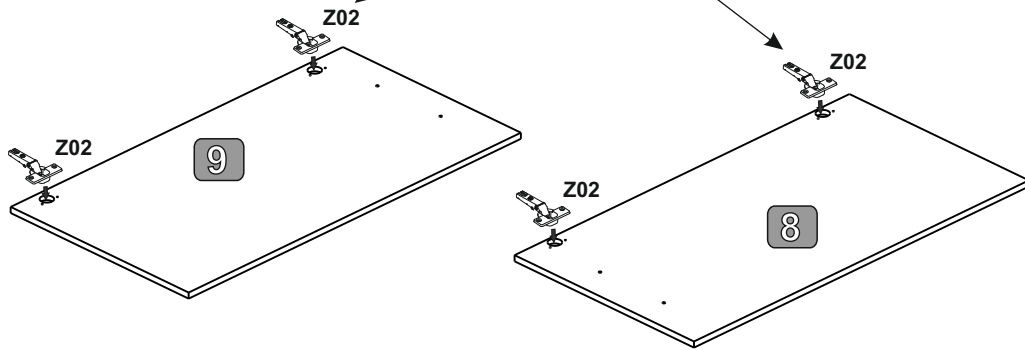
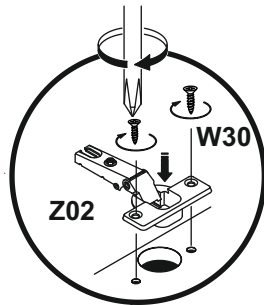
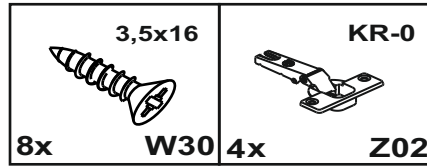

11

